

SUBMITTAL DATA: MSZ-D30NA & MUZ-D30NA

30,000 BTU/H WALL-MOUNTED HEAT-PUMP SYSTEM

Job Name:	Location:	Date:
Purchaser:	Engineer:	
Submitted to:	For <input type="checkbox"/> Reference <input type="checkbox"/> Approval <input type="checkbox"/> Construction	
System Designation:	Schedule No.:	

GENERAL FEATURES

- Catechin and anti-allergy enzyme filters for high air-purification capabilities
- Updated sleek, compact indoor unit design
- Remote-controlled wide airflow enables ideal horizontal air distribution
- Self-check function—onboard diagnostics
- Advanced microprocessor control
- Auto restart following a power outage
- Hand-held Wireless Remote Controller
- Anti-allergy Enzyme Filter
- Limited warranty: five years on parts and defects and seven years on compressors

OPTIONAL ACCESSORIES
Outdoor Unit

- Drain Socket Assembly (MAC-811DS)

Indoor Unit

- Condensate Pump (230V; SI3100-230)

Controller Options

- Wall-mounted Wired Remote Controller (PAR-21MAA; Requires MAC-3971F)
- M-NET Control Adapter (MAC-399IF)
- MA Contact Terminal Interface (MAC-397IF)

Cooling*

Rated Capacity 30,700 Btu/h
 Minimum Capacity 9,800 Btu/h
 SEER 14.5 Btu/h/W
 Total Input 3,850 W

Heating at 47° F*

Rated Capacity 32,600 Btu/h
 Minimum Capacity 8,700 Btu/h
 HSPF 8.2 Btu/h/W
 Total Input 3,360 W

Heating at 17° F*

Rated Capacity 19,500 Btu/h
 Maximum Capacity 20,800 Btu/h
 Maximum Total Input 2,620 W

* Rating Conditions (Cooling) - Indoor: 80°F (27°C) DB, 67°F (19°C) WB; Outdoor: 95°F (35°C) DB, 75°F (24°C) WB.

(Heating at 47° F) - Indoor: 70°F (21°C) DB, 60°F (16°C) WB; Outdoor: 47°F (8°C) DB, 43°F (6°C) WB.

(Heating at 17° F) - Indoor: 70°F (21°C) DB, 60°F (16°C) WB; Outdoor: 17°F (-8°C) DB, 15°F (-9°C) WB.

Power Supply 208 / 230V, 1-Phase, 60 Hz
 Breaker Size 25 A

Voltage

Indoor - Outdoor S1-S2 AC 208 / 230V
 Indoor - Outdoor S2-S3 DC 12-24V
 Indoor - Remote Controller Wireless

OPERATING RANGE

		Indoor Intake Air Temp.	Outdoor Intake Air Temp.
Cooling	Maximum	90°F (32°C) DB, 73°F (23°C) WB	115°F (46°C) DB
	Minimum	67°F (19°C) DB, 57°F (14°C) WB	14°F (-10°C) DB
Heating	Maximum	80°F (27°C) DB, 67°F (19°C) WB	75°F (24°C) DB, 65°F (18°C) WB
	Minimum	70°F (27°C) DB, 60°F (16°C) WB	14°F (-10°C) DB, 13°F (-11°C) WB

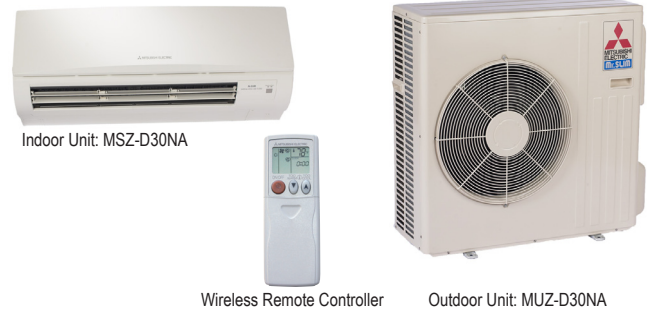
Indoor Unit

MCA 1 A
 Fan Motor 0.76 F.L.A.
 Airflow
 Cooling (Lo - Med - Hi - Powerful) 389 - 639 - 848 - 887 Dry CFM
 350 - 576 - 763 - 798 Wet CFM
 Heating (Lo - Med - Hi - Powerful) . 445 - 639 - 848 - 887 Dry CFM

Sound Pressure Level

Cooling (Lo - Med - Hi - Powerful) 32 - 42 - 49 - 51 dB(A)
 Heating (Lo - Med - Hi - Powerful) 34 - 42 - 49 - 50 dB(A)

DIMENSIONS	UNIT INCHES / MM
W	46-1/16 / 1,170
D	11-5/8 / 295
H	14-3/8 / 365

Weight 40 lbs. / 18 kg
 External Finish Munsell No. 1.0Y 9.2 / 0.2
 Field Drainpipe Size O.D. 5/8" / 15.88 mm
 Remote Controller Wireless
 (Optional Wired Remote Controller PAR-21MAA see Data Submittal Sheet)

Outdoor Unit

Compressor DC Inverter-driven Rotary
 MCA 21 A
 Fan Motor 0.93 F.L.A.
 Sound Pressure Level
 Cooling 55 dB(A)
 Heating 57 dB(A)

DIMENSIONS	INCHES / MM
W	33-1/16 / 840
D	13 / 330
H	33-7/16 / 849

Weight 141 lbs. / 64 kg
 External Finish Munsell No. 3Y 7.8 / 1.1

Refrigerant Type R410A
 Refrigerant Pipe Size O.D.
 Gas Side 5/8" / 15.88 mm
 Liquid Side 3/8" / 9.53 mm
 Max. Refrigerant Pipe Length 100' / 30 m
 Max. Refrigerant Pipe Height Difference 50' / 15 m
 Connection Method Flared



DIMENSIONS: MSZ-D30NA & MUZ-D30NA

MSZ-D30NA

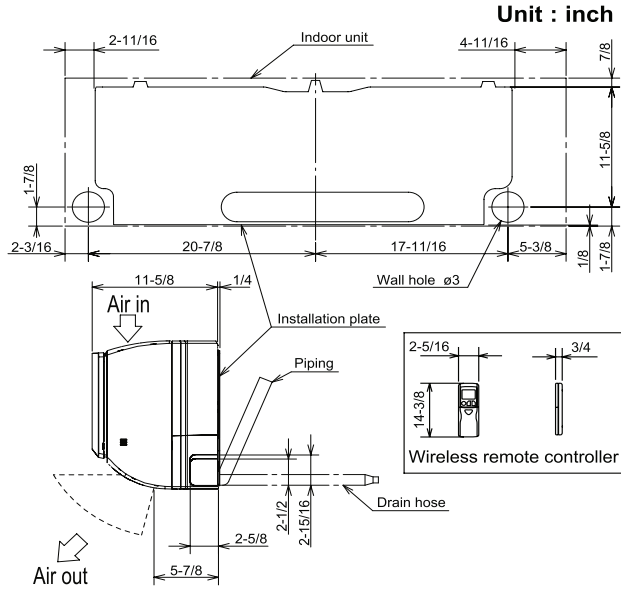
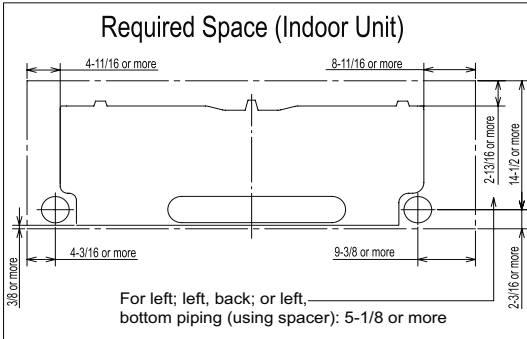
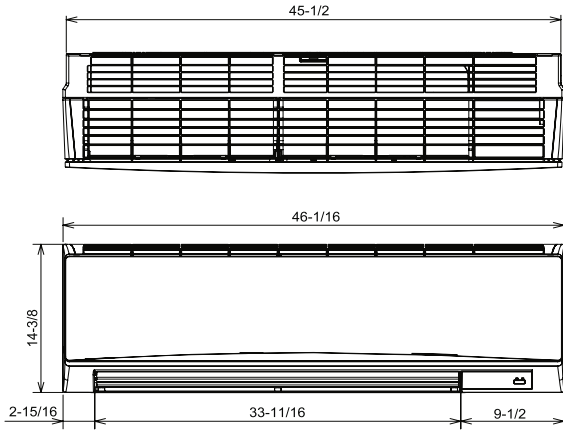

Unit : inch

	Piping	Insulation
Liquid line	ø3/8 19-11/16 (Flared connection ø3/8)	ø1-1/4 O.D. ø9/16 I.D.
Gas line	ø5/8 16-7/8 (Joint connection ø5/8)	ø1-15/16 O.D. ø1-1/4 I.D.
Joint	ø5/8 (Flared connection ø5/8)	ø1-15/16 O.D. ø1-1/4 I.D.
Drain hose	Insulation ø1-1/8 Connected part ø9/16 O.D.	

MUZ-D30NA

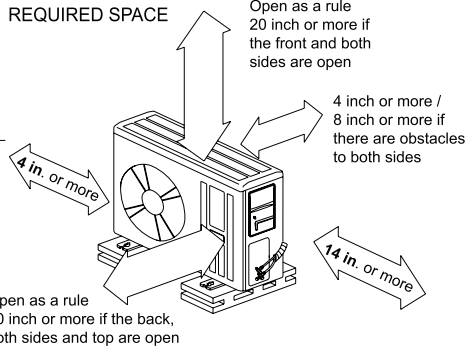
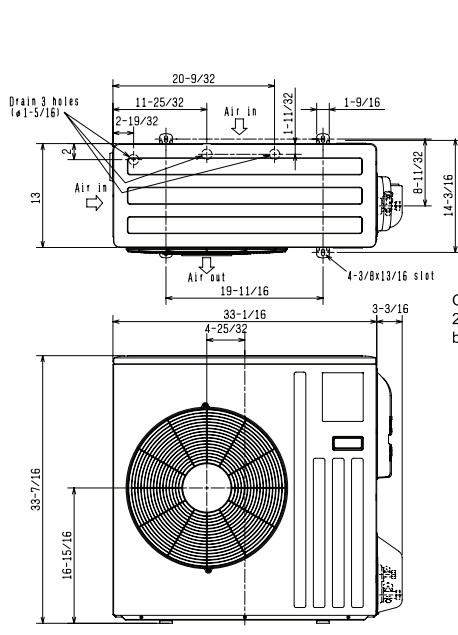

Unit: inch



Intertek

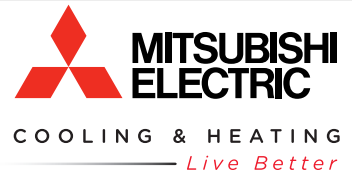

3400 Lawrenceville Suwanee Rd
Suwanee, GA 30024
Tele: 678-376-2900 • Fax: 800-889-9904
Toll Free: 800-433-4822 (#3)
www.mehvac.com
Specifications are subject to change without notice.

SUBMITTAL DATA: MSZ-D36NA & MUZ-D36NA

36,000 BTU/H WALL-MOUNTED HEAT-PUMP SYSTEM

Job Name:	Location:	Date:
Purchaser:	Engineer:	
Submitted to:	For <input type="checkbox"/> Reference <input type="checkbox"/> Approval <input type="checkbox"/> Construction	
System Designation:	Schedule No.:	

GENERAL FEATURES

- Catechin and anti-allergy enzyme filters for high air-purification capabilities
- Updated sleek, compact indoor unit design
- Remote-controlled wide airflow enables ideal horizontal air distribution
- Self-check function—onboard diagnostics
- Advanced microprocessor control
- Auto restart following a power outage
- Hand-held Wireless Remote Controller
- Anti-allergy Enzyme Filter
- Limited warranty: five years on parts and defects and seven years on compressors

OPTIONAL ACCESSORIES
Outdoor Unit

- Drain Socket Assembly (MAC-811DS)

Indoor Unit

- Condensate Pump (230V; SI3100-230)

Controller Options

- Wall-mounted Wired Remote Controller (PAR-21MAA; Requires MAC-3971F)
- M-NET Control Adapter (MAC-3991F)
- MA Contact Terminal Interface (MAC-3971F)

Cooling*

Rated Capacity 33,200 Btu/h
 Minimum Capacity 9,800 Btu/h
 SEER 14.5 Btu/h/W
 Total Input 4,360 W

Heating at 47° F*

Rated Capacity 35,200 Btu/h
 Minimum Capacity 8,700 Btu/h
 HSPF 8.2 Btu/h/W
 Total Input 3,840 W

Heating at 17° F*

Rated Capacity 21,800 Btu/h
 Maximum Capacity 22,800 Btu/h
 Maximum Total Input 3,000 W

* Rating Conditions (Cooling) - Indoor: 80°F (27°C) DB, 67°F (19°C) WB; Outdoor: 95°F (35°C) DB, 75°F (24°C) WB.

(Heating at 47° F) - Indoor: 70°F (21°C) DB, 60°F (16°C) WB; Outdoor: 47°F (8°C) DB, 43°F (6°C) WB.

(Heating at 17° F) - Indoor: 70°F (21°C) DB, 60°F (16°C) WB; Outdoor: 17°F (-8°C) DB, 15°F (-9°C) WB.

Power Supply 208 / 230V, 1-Phase, 60 Hz
 Breaker Size 25 A

Voltage

Indoor - Outdoor S1-S2 AC 208 / 230V
 Indoor - Outdoor S2-S3 DC 12-24V
 Indoor - Remote Controller Wireless

OPERATING RANGE

		Indoor Intake Air Temp.		Outdoor Intake Air Temp.
Cooling	Maximum	90°F (32°C) DB, 73°F (23°C) WB	115°F (46°C) DB	
	Minimum	67°F (19°C) DB, 57°F (14°C) WB	14°F (-10°C) DB	
Heating	Maximum	80°F (27°C) DB, 67°F (19°C) WB	75°F (24°C) DB, 65°F (18°C) WB	
	Minimum	70°F (27°C) DB, 60°F (16°C) WB	14°F (-10°C) DB, 13°F (-11°C) WB	



Indoor Unit: MSZ-D36NA



Wireless Remote Controller



Outdoor Unit: MUZ-D36NA

Indoor Unit

MCA 1 A
 Fan Motor 0.76 F.L.A.
 Airflow
 Cooling (Lo - Med - Hi - Powerful) 389 - 639 - 848 - 887 Dry CFM
 350 - 576 - 763 - 798 Wet CFM
 Heating (Lo - Med - Hi - Powerful) . 445 - 639 - 848 - 887 Dry CFM

Sound Pressure Level

Cooling (Lo - Med - Hi - Powerful) 32 - 42 - 49 - 51 dB(A)
 Heating (Lo - Med - Hi - Powerful) 34 - 42 - 49 - 50 dB(A)

DIMENSIONS	UNIT INCHES / MM
W	46-1/16 / 1,170
D	11-5/8 / 295
H	14-3/8 / 365

Weight 40 lbs. / 18 kg
 External Finish Munsell No. 1.0Y 9.2 / 0.2
 Field Drainpipe Size O.D. 5/8" / 15.88 mm
 Remote Controller Wireless
 (Optional Wired Remote Controller PAR-21MAA see Data Submittal Sheet)

Outdoor Unit

Compressor DC Inverter-driven Rotary
 MCA 21 A
 Fan Motor 0.93 F.L.A.
 Sound Pressure Level
 Cooling56 dB(A)
 Heating57 dB(A)

DIMENSIONS	INCHES / MM
W	33-1/16 / 840
D	13 / 330
H	33-7/16 / 849

Weight 141 lbs. / 64 kg
 External Finish Munsell No. 3Y 7.8 / 1.1
 Refrigerant Type R410A
 Refrigerant Pipe Size O.D.
 Gas Side 5/8" / 15.88 mm
 Liquid Side 3/8" / 9.53 mm
 Max. Refrigerant Pipe Length 100' / 30 m
 Max. Refrigerant Pipe Height Difference 50' / 15 m
 Connection Method Flared

INVERTER

DIMENSIONS: MSZ-D36NA & MUZ-D36NA

MSZ-D36NA

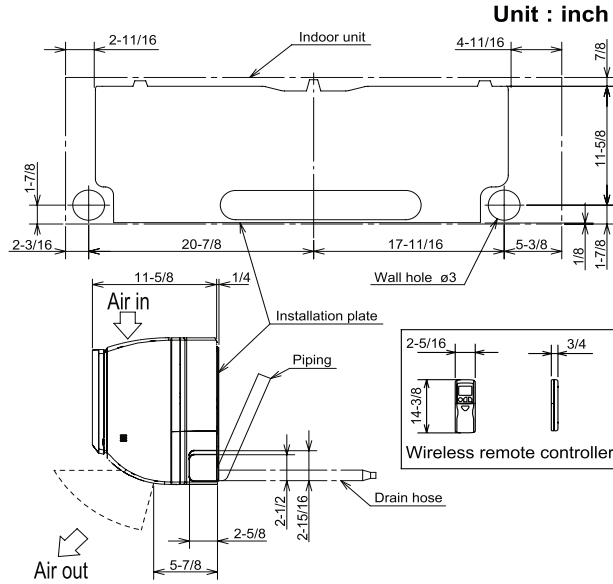
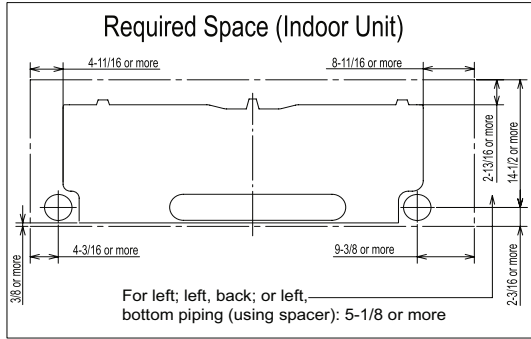
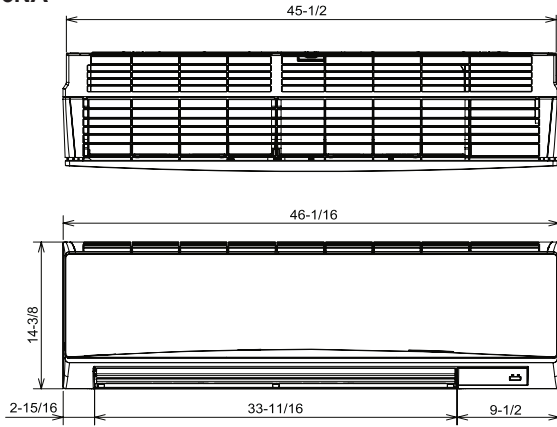

	Piping	Insulation
Liquid line	$\phi 3/8$ 19-11/16 (Flared connection $\phi 3/8$)	$\phi 1-1/4$ O.D. $\phi 9/16$ I.D.
Gas line	$\phi 5/8$ 16-7/8 (Joint connection $\phi 5/8$)	$\phi 1-15/16$ O.D. $\phi 1-1/4$ I.D.
Joint	$\phi 5/8$ (Flared connection $\phi 5/8$)	$\phi 1-15/16$ O.D. $\phi 1-1/4$ I.D.
Drain hose	Insulation $\phi 1-1/8$ Connected part $\phi 9/16$ O.D.	

MUZ-D36NA

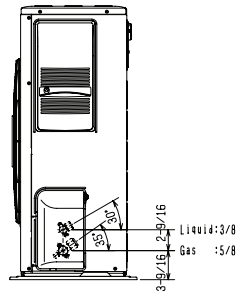
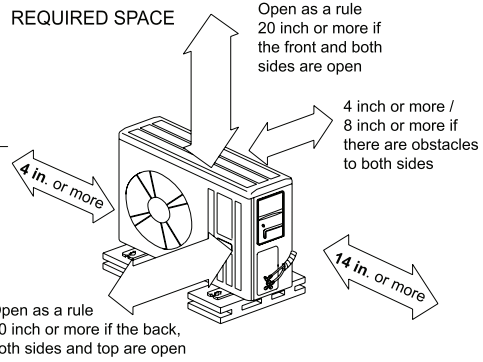
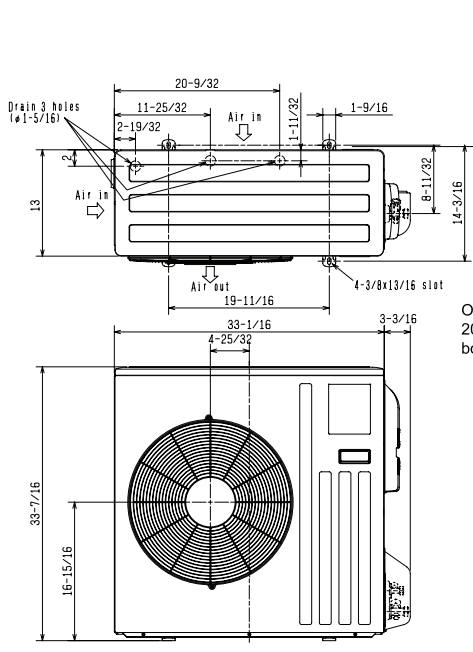

Intertek

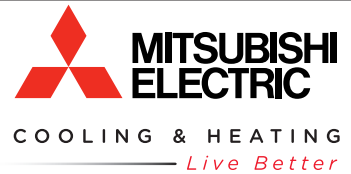

3400 Lawrenceville Suwanee Rd
 Suwanee, GA 30024
 Tele: 678-376-2900 • Fax: 800-889-9904
 Toll Free: 800-433-4822 (#3)
 www.mehvac.com
Specifications are subject to change without notice.