



TECHNICAL GUIDE

**SINGLE PACKAGE
AIR CONDITIONER / ELECTRIC HEAT
14 SEER – R-410A – 208/230V - 1 PHASE
2 THRU 5 NOMINAL TONS
MODELS: PCE4*24 THRU 60**



Due to continuous product improvement, specifications are subject to change without notice.

Visit us on the web at www.upgnet.com and www.luxaire.com

Additional rating information can be found at: www.ahridirectory.org

WARRANTY SUMMARY*

Extended 10-Years limited parts and compressor warranty

* Extended warranty requires online registration within 90 days of purchase for replacement or closing for new home purchase. See limited warranty certificate in User's Information Manual for details.

DESCRIPTION

These packaged cooling/heating air conditioners are designed for outdoor installation. Only utility and duct connections are required at the point of installation.

FEATURES

- **Operating Efficiency** - All PCE4 air conditioner models are rated at 14.0 SEER and 11.0 EER for cooling operation.
- **On Site Flexibility** - All model sizes use a compact design cabinet in one of two footprints. This provides installer flexibility for placing the proper capacity unit on curbs or pads with the smallest footprint after the internal load has been determined. Field convertible duct connections from side shot to down shot allows the installer to have greater flexibility with less inventory.
- **Lower Installation Cost** - Installation time and costs are reduced by easy power and control wiring connections. The small base dimension means less space is required on the ground or roof. All units are completely wired, charged with R-410A and tested prior to shipment. Test stations using a state-of-the-art computerized process system are used to insure product quality. Refrigerant charge and component part numbers are verified via computers during assembly. Vital run test statistics such as system pressure, motor currents, air velocity and temperature, unit vibration, and gas system safeties are monitored and recorded by the system to insure unit performance. Equal size side supply and return duct connections allow easy connection of ducts to match low crawl spaces without transition pieces.
- **Utility Connections Made Easy** - Electric utility access provided through the bottom or the side of the unit. Utility connections can be made quickly and with a minimum amount of field labor. A field supplied and field installed electrical disconnect switch must be installed.
- **Convertible Airflow Design** - The bottom duct openings are covered when they leave the factory, ready to be used for a side supply/side return application. If a bottom supply/bottom return application is desired, simply remove the two panels from the bottom of the unit and place them in the side supply/side return duct openings. No panel cutting is required and no accessory panel is necessary. Convertible airflow design allows maximum field flexibility and minimum inventory.
- **Condensate Pan** - A corrosion-resistant, long-lasting, water-tight pan is positioned below the indoor coil to collect and drain all condensate, preventing build-up of stagnant condensate. The condensate pan conforms to ASHRAE 62-89 standards (Ventilation for Acceptable Indoor Air Quality).
- **Condensate Drain** - The 3/4 inch NPT female connection is rigidly mounted to assure proper fit and leak tight seal.
- **Durable Finish** - The cabinet is made of G90 galvanized steel with a powder paint coating for appearance and protection. The pre-treated galvanized steel provides a better paint-to-steel bond, which resists corrosion and rust creep. Powder paint finish ensures less fading when exposed to sunlight, and provides superior corrosion resistance (1000 hour salt spray tested).

Continued on next page.

- **Full Perimeter Base Rails** - The easily removable base rails provide a solid foundation for the entire unit and protects the unit during shipment. The rails provide fork lift access from all sides, and rigging holes are also provided so that an overhead crane can be used to place the units on a roof. On applications where the unit is placed on a pad, the base will keep the unit off the pad to deter corrosion. On applications where height is limited, the base rails may be removed by removing 2 screws in each corner.
- **Attractive Appearance** - A single-piece top cover containing a top-discharge condenser fan arrangement requires less square footage on installation and provides a wider variety of installations. The one-piece design adds greater water integrity. Rounded corners with water drip edges add to the attractive appearance.
- **Top Discharge** - The top-discharge outdoor fan does not disrupt neighboring areas or dry out vegetation surrounding the unit. The warm air from the top mounted fan is blown up and away from the structure and any landscaping.
- **Outdoor Coil Grille** - All models utilize a stamped slotted design which provides superior impact protection against small objects during transit and after installation.
- **Low Operating Sound Level** - The upward air flow carries the normal operating noise up and away from the living area. The rigid top panel effectively isolates noise. Isolator mounted compressor and the rippled fins of the outdoor coil muffle the normal fan motor and compressor operating sounds. The unique formed base pan also aids in sound attenuation with its structural design.
- **Fan System** - All models operate over a wide range of design conditions with a standard ECM indoor fan motor. These units easily match all types of applications and provide greater on-site flexibility to match comfort requirements. The cooling speed is factory-set and can be field-adjusted to a second speed. The heating speed is factory set to maintain mid point rise at the units heating input, but can be field adjusted. This allows maximum comfort conditions.
- **Simple Control Circuit** - Field thermostat wiring connects to color coded leads using twist on wire connections. Cooling controls use contactor and relays for simple application and troubleshooting. Mate-n-lock plug connectors are used. The electrical control box is not located in the compressor compartment. The controls are mounted to allow the separate access panel to be removed for trouble shooting and maintenance without affecting the normal system operating pressures. All wiring internal to the unit is color/number coded.
- **Protected Compressor** - The compressor is internally protected against high pressure and temperature. This is accomplished by the simultaneous operation of high pressure relief valve and a temperature sensor which protect the compressor if undesirable operating conditions occur.
- **Pressure Switches** - A high pressure switch is standard in all units. It is an automatic reset switch. When discharge pressure reaches 650 psi, the compressor will de-energize until pressure reaches 450 psi.
- **Exclusive Coil Design** - Grooved copper tubes and enhanced aluminum fin construction improves heat transfer for maximum efficiency and durability for long-lasting durability and efficient operation. Indoor coils will use tin-coated copper tubing with aluminum fins for effective heat transfer.
- **Electric Heat** - All electric heat models use 6HK electric heat, which are available in 230v/1/60 from 2 kW to 25 kW. Most kits stageable above 10 kW. Single phase single point field wiring kits are available for all applications except 25kW.
- **Low Maintenance** - Long life, permanently lubricated condenser and evaporator fan motor bearings need no annual maintenance, adding greater reliability to the unit. Slide-out blower assembly and evaporator coil assembly can be easily removed for cleaning.
- **Easy Service Access** - Individual access panels are provided in access to all major components - compressors, evaporator coils, blower, controls/electric heat kits, filters, etc. that makes servicing easy. Removing these panels allow easy removal of the components such as the blower assembly for maintenance and ease of troubleshooting.
- **Replacement Parts** - The installer requires no special training to replace any of the components of these units and the number of new components have been reduced to minimize the inventory of unique parts.

NOMENCLATURE

PCE	4	A	24	50	2	X	1	A
1	2	3	4		6		8	9
1. Model Family PCE - packaged A/C with electric heat, PHE - packaged heat pump with electric heat, PCG - packaged A/C with gas heat, PHG - packaged heat pump with gas heat, 2. Nominal Cooling Efficiency 4 = 14 SEER, 6 = 16 SEER, etc. 3. Cabinet Size A = small 35 x 51, B = large 45 x 51 4. Nominal Air Conditioning Cooling Capacity BTUx1000 24 = 24,000 BTU, etc. Examples: PCE4B4221A is a packaged air conditioner, 14 SEER, 3-1/2 ton, large cabinet, 230 volt, single phase model, (first generation, first release)					5. Gas Heating Input BTU/Hr x 1000 050 = 50,000 BTU/Hr. input, blank = electric heat 6. Voltage-Phase-Frequency 2 = 208/230-1-60, 3=208/230-3-60, 4 = 460-3-60 7. NOx Approval X = low-NOx, blank = not low-Nox 8. Generation Level 1 = first generation 9. Revision Level A = original release, B = second release			

COMPONENT LOCATION

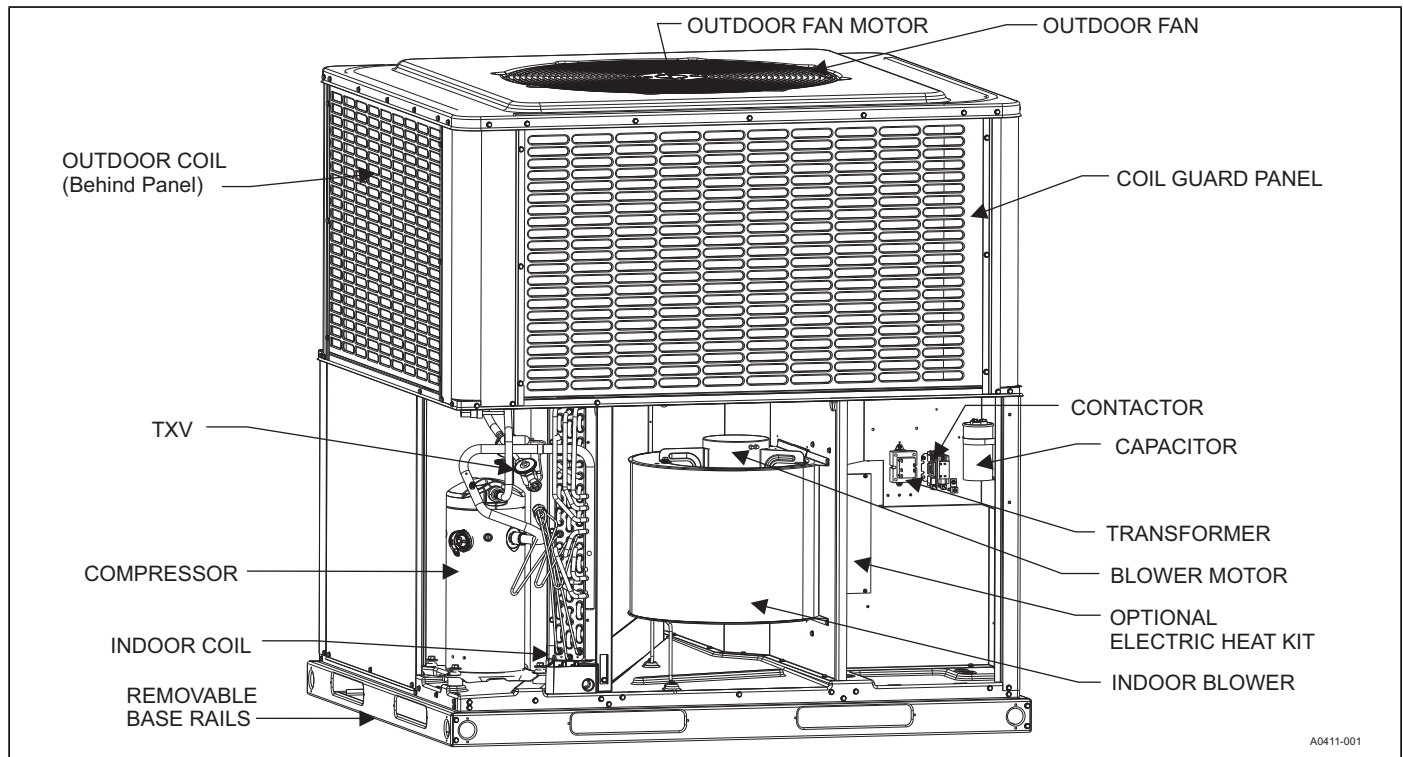

UNIT LIMITATIONS

Model	Unit Voltage	Unit Limitations		
		Applied Voltage		Outdoor DB Temp
		Min	Max	Max (°F)
PCE4A2422	208/230-1-60	187	252	125
PCE4A3022	208/230-1-60	187	252	125
PCE4A3622	208/230-1-60	187	252	125
PCE4A4221	208/230-1-60	187	252	125
PCE4B4822	208/230-1-60	187	252	125
PCE4B6022	208/230-1-60	187	252	125

ACCESSORIES

- **Economizer for Downflow Applications (S1-2EE04710024, S1-2EE04710124)** - Modulating integrated economizer provides simultaneous operation between mechanical cooling and economizer operation. Independent blade design insures proper control and less than 1% leak rate. Includes hood and mesh bird screen filter integrated into the hood, dry bulb sensor and barometric relief damper. Separate field accessories of single/dual enthalpy kits are also available.
 - **Economizer for Horizontal Applications (S1-2EE04710224, S1-2EE04710324)** - Modulating integrated economizer provides simultaneous operation between the mechanical cooling and economizer operation. Independent blade design insures proper control and less than 1% leak rate. Includes hood and mesh bird screen filter integrated into hood, dry bulb sensor. Separate field accessories of single enthalpy and dual enthalpy are available.
 - **Barometric Relief Hood (S1-1RD0501)** - Used in conjunction with a horizontal economizer, the Barometric Relief Hood helps to equalize the building pressure that is caused by the fresh air that is introduced through the economizer fresh air hood.
 - **Single/Dual Enthalpy Sensor (S1-HE-6863-0N00WS)** - Sensor replaces supply air temperature dry bulb sensor standard in economizer kit. Provides improved economizer operation by sensing the dry bulb temperature of indoor supply air plus the enthalpy content of the outdoor air.
 - **Duct/Unit Mount CO2 Kit (S1-2AQ04700924)** - Sensor kit detects CO2 levels automatically and overrides the economizer when CO2 levels rise above the preset limits.
 - **Wall Mount CO2 Kit (S1-2AQ04701024)** - Sensor kit detects CO2 levels automatically and overrides the economizer when CO2 levels rise above the preset limits.
 - **Supply Air Temperature Sensor Kit (S1-TE-63616E-2D)** - Outdoor supply air temperature sensor kit used with economizers.
 - **Filter/Frame Kit (S1-1FF0602, S1-1FF0601)** - Kit contains the necessary hardware to field install return air filters into the base unit. The filter rack is suitable for either 1" or 2" filters.
 - **Filter (S1-02647812000)** - Washable 1" filter. Two filters are required for A base units. Three filters are required for B base units.
 - **Motorized Fresh Air Damper (S1-2MD04705224, S1-2MD04705124)** - Designed for duct mounted side supply/return and unit mounted down supply/return applications. Damper capable of providing 0% through 50% of outdoor air (field supplied). Closes on power loss, includes hood and screen assembly.
 - **Rectangle to Round (Horizontal) Adapter (S1-1AK0110, S1-1AK0111)** - Kit includes one supply and one return air rectangle to round duct adapter. Adapters are preformed and designed to fit over current horizontal duct openings on the base unit. Transition is from rectangle to 12" round for the 1AK0110 kit and from rectangle to 14" round for the 1AK0111 kit.
 - **Rectangle to Round (Downflow) Adapter (S1-1AK0108, S1-1AK0109)** - Kit includes one supply and one return air rectangle to round duct adapter. Adapters are preformed and designed to fit into current downflow duct openings on the roof curb. Transition is from rectangle to 16" round for the 1AK0108 kit and from rectangle to 18" round for the 1AK0109 kit.
 - **Roof Curbs (S1-1RC0503, S1-1RC0501)** - NRCA approved curbs provide proper fit to base unit for rooftop installations. Curbs are designed to be assembled through hinge pins in each corner. Kit also provides seal strip to assure an air tight seal. These are 8 inch high roof curbs.
 - **Roof Curbs (S1-1RC0504, S1-1RC0502)** - NRCA approved curbs provide proper fit to base unit for rooftop installations. Curbs are designed for assembly through hinge pins in each corner. Kit also provides seal strip to assure air tight seal. These are 14 inch high roof curbs.
 - **Transition Curb Kits (S1-1TC01*)** - Adapter kits to allow field use of pre-existing installed roof curbs to match PCE4 footprint to Affinity roof curbs, Carrier, Trane, or Goodman curb footprints. Curb adapters are optional for current generation Carrier replacements but are recommended for previous generation applications. Refer to the PCE4 price pages for more details.
 - **Manual Outdoor Damper (S1-1FA0502, S1-1FA0501)** - Provides 0% through 50% outdoor air capability (field adjustable). Designed for duct mounted side supply/return applications and unit mounted down supply/return applications. Includes hood and screen assembly.
 - **Transformer Kit (S1-2EC06700124)** - Kit provides necessary hardware to provide single phase models from factory furnished 40 VA transformer capability to 75 VA transformer capability. (Required on installations with economizer or motorized damper).
 - **Loss of Charge Switch (S1-2LC00024)** - Kit provides Loss of Charge switch and wiring to provide safe shutdown of compressor.
 - **Low Ambient Kit (S1-2LA04701024)** - Kit provides necessary hardware to convert unit to operate in cooling cycle down to 0° F. Standard unit operation 45° F.
 - **Base Rail Hole Cover Kit (S1-1HC0101)** - Kit provides necessary hardware to close off openings in base rails to block off openings, i.e. prevent animal entrance.
 - **Single Point Wiring Kits for 6HK Electric Heat Applications (S1-SPWK*)** - Kits provide field option for connecting electrical power supplies to the field installed 6HK kits to allow single point connections for single phase electric heat applications with the exception of 25kW kits.
 - **Thermostat** - Compatible thermostat controls are available through accessory sourcing. For optimum performance, these outdoor units are fully compatible with the Luxaire Hx™ Touchscreen Thermostat available through Source1. For more information, see the thermostat section of the Product Equipment Catalog.
 - **Wall Thermostat** - The units are designed to operate with standard, 24-volt electronic non power stealing and electro-mechanical thermostats. All units can operate with single stage heat/single stage cool thermostats - with or without the economizer.
 - **Crankcase Heater** - 40W Accessory kits are available for scroll models through Source 1.
- * For additional kit numbers refer to the price pages.

GUIDE SPECIFICATIONS

GENERAL

Units shall be manufactured by Unitary Products in an ISO 9001 certified facility. These packaged cooling and heating air conditioners are designed for outdoor installation. Only utility and duct connections are required at the point of installation. Air Conditioning units provide electric cooling and electric heating, with field installed electric heat kits from 2 kW to 25 kW for heating operation.

DESCRIPTION

Units shall be factory-assembled, single packaged, Air Conditioners with Electric Cooling/Electric Heating units, designed for outdoor installation. They shall have built in, equal size, field convertible duct connections for supply/return or horizontal supply/return. The units shall be factory wired, piped, charged with R-410A Refrigerant and factory tested prior to shipment. All models shall be rated in accordance with DOE and AHRI test procedures for both heating and cooling operation. Units shall be CSA listed to the UL 1995/CAN/CSA No. 236-M90 standards.

- **Operating Efficiency** - All models shall be rated at a minimum of 14.0 SEER and 11.0 EER for cooling and heating operation rated in accordance with DOE requirements.
- **Low Operating Sound Level** - The upward air flow carries the normal operating noise up and away from the living area. The rigid top panel effectively isolates noise. Isolator mounted compressor and the rippled fins of the condenser coil muffle the normal fan motor and compressor operating sounds. The unique formed base pan also aids in sound attenuation with its structural design. Sound ratings as tested under AHRI test procedures shall be less than 77 dbA for all models.

UNIT CABINET

Unit cabinet shall be a single piece design, with drip edges and no-seam corners to provide optimum water integrity. Unit shall have a rigidly mounted condenser coil guard to provide protection from objects and personnel after installation. Indoor blower section shall be insulated with foil-faced or foam insulation, fastened to prevent insulation from entering the air stream. Cabinet panels shall be separate, easily removable for servicing and maintenance. Unit shall be built on a formed, design base pan, with embossments at critical points to add strength and rigidity and to aid in minimizing sound. Full perimeter base rails shall be provided to assure reliable transit of equipment, overhead rigging, for truck access and proper sealing on roof curb applications. Base rails shall be easily removable, when required to lower unit height. Filters shall be field installed, furnished and be accessible through a removable access door, sealed airtight. Units vertical discharge and return duct configuration shall be designed to fit between standard 24" O.C. beams without modification to building structure, duct work and base unit.

- **Durable Finish** - The cabinet shall be is made of G90 galvanized steel with a powder paint coating for appearance and protection. The pre-treated galvanized steel shall provide a better paint-to-steel bond, which resists corrosion and rust creep. Powder paint finish shall provide superior corrosion resistance (1000 hour salt spray tested).

- **On Site Flexibility** - All model sizes shall use a compact design cabinet in one of two footprints. This provides installer flexibility for placing the proper capacity unit on curbs or pads with the smallest footprint after the internal load has been determined. Field convertible duct connections from side shot to down shot allows the installer to have greater flexibility with less inventory.
- **Attractive Appearance** - A single-piece top cover containing a top-discharge condenser fan arrangement shall be used which requires less square footage on installation and provides a wider variety of installations. The one-piece design adds greater water integrity. Rounded corners with water drip edges add to the attractive appearance and prevent water penetration.
- **Convertible Airflow Design** - The bottom duct openings are covered when they leave the factory, ready to be used for a side supply/side return application. If a bottom supply/bottom return application is desired, simply remove the two panels from the bottom of the unit and place them in the side supply/side return duct openings. No panel cutting is required and no accessory panel is necessary. Convertible airflow design allows maximum field flexibility and minimum inventory.
- **Utility Connections Made Easy** - Electric utility access shall be provided through the bottom or the side of the unit. Utility connections should be made quickly and with a minimum amount of field labor. A field supplied and field installed electrical disconnect switch must be installed.
- **Easy Service Access** - Individual access panels are provided in access to all major components - compressors, indoor coils, blower, controls/electric heat kits, filters, etc. that makes servicing easy. Removing these panels allow easy removal of the components such as the blower assembly for maintenance and ease of troubleshooting.
- **Top Discharge** - The top-discharge outdoor fan does not disrupt neighboring areas or dry out vegetation surrounding the unit. The warm air from the top mounted fan is blown up and away from the structure and any landscaping.
- **Outdoor Coil Grille** - All models utilize a stamped slotted design which provides superior impact protection against small objects during transit and after installation.

Indoor Blower Assembly - Fan shall be direct drive design. Fan wheel shall be double-inlet type with forward-curved blades, dynamically balanced to operate smoothly throughout the entire range of operation. Airflow design shall be constant air volume. Bearings shall be sealed and permanently lubricated for longer life and no maintenance. Fan assembly shall be a slide-out design for easy removal and cleaning. Indoor blower motors shall be equipped with a standard high efficiency brushless DC motor (constant torque) also known as a standard ECM motor.

Outdoor Fan Assembly - The outdoor fan shall be of the direct-driven propeller type, discharge air vertically, have aluminum blades riveted to corrosion resistant steel spider bracket and shall be statically balanced for smooth operation. The outdoor fan motor shall be totally enclosed with permanently lubricated bearings and internally protected against overload conditions.

REFRIGERANT COMPONENTS

- **Protected Compressor** - The compressor shall be a fully hermetic type, direct drive compressor, that is internally protected against high pressure and temperature. This is accomplished by the simultaneous operation of high pressure relief valve and a temperature sensor which protect the compressor if undesirable operating conditions occur. The hermetic motor shall be suction gas cooled and have a voltage range of +/- 10% of the unit nameplate voltage. Compressors shall have internal isolation and sound muffling to minimize vibration and noise, and be externally isolated on a dedicated, independent mounting.
- **Indoor Coils** - Indoor coils shall be of the direct expansion, draw through design and have aluminum plate fins mechanically bonded to seamless internally enhanced tin-coated copper tubes with all joints brazed.
- **Condensate Pan** - A corrosion-resistant, long-lasting, water-tight pan is positioned below the indoor coil to collect and drain all condensate, preventing build-up of stagnant condensate. The condensate pan conforms to ASHRAE 62-89 standards (Ventilation for Acceptable Indoor Air Quality).
- **Condensate Drain** - The 3/4 inch NPT female connection is rigidly mounted to assure proper fit and leak tight seal.
- **Outdoor Coils** - Outdoor coils shall have aluminum plate fins mechanically bonded to seamless internally enhanced copper tubes with all joints brazed, and be a draw through design.

Refrigerant Circuit and Refrigerant Safety Components shall include: Thermal expansion devices (TXV's) shall be factory mounted and provided, Filter/strainer to eliminate any foreign matter, reversing valves to control refrigerant flow.

CONTROLS

- **Simple Control Circuit** - Field thermostat wiring connects to color coded leads using twist on wire connections. Cooling controls use contactor and relays for simple application and troubleshooting. Mate-n-lock plug connectors are used. The electrical control box is not located in the compressor compartment. The controls are mounted to allow the separate access panel to be removed for trouble shooting and maintenance without affecting the normal system operating pressures. All wiring internal to the unit is color/number coded.
- **Pressure Switches** - A high pressure switch is standard in all units. It is an automatic reset switch. When discharge pressure reaches 650 psi, the compressor will de-energize until pressure reaches 450 psi.
- **Factory Testing** - Installation time and costs are reduced by easy power and control wiring connections. All units are completely wired, charged with R-410A and tested prior to shipment. Test stations using a state-of-the-art computerized process system shall be used to insure product quality. Refrigerant charge and component part numbers are verified via computer bar code scans during assembly. Vital run test statistics such as system pressure, motor currents, air velocity and temperature, unit vibration, and gas system safeties are monitored and recorded by the system to insure unit performance. This data could be provided by serial number tracking if requested.
- **Electric Heat** - All electric heat models use 6HK electric heat, which are available in 230v/1/60 from 2 kW to 25 kW, 230v/3/60 10kW to 25kW, and 460v/3/60 10kW to 25kW. Most kits stageable above 10 kW. Single point accessory kits are available for single phase models. Single phase single point field wiring kits are available for all applications except 25kW. Electric heat kits must be certified to UL 1995 standard requirements.

PHYSICAL DATA

MODELS:	PCE4A2422	PCE4A3022	PCE4A3622	PCE4A4221	PCE4B4822	PCE4B6022
NOMINAL TONNAGE:	2.0	2.5	3.0	3.5	4.0	5.0
COMPONENT						
Gross Capacity @ AHRI A point (MBH)	23.7	30.1	37.2	43.5	47.7	57.0
AHRI net capacity (MBH)	22.8	29.0	34.6	40.7	45.5	55.0
EER	11.2	11.2	11.2	11.2	11.2	11.2
SEER	14.0	14.0	14.0	14.0	14.0	14.0
Nominal CFM	800	1000	1200	1400	1600	2000
System power (KW)	2.1	2.6	3.2	3.8	4.2	4.8
Refrigerant type	R410A	R410A	R410A	R410A	R410A	R410A
Refrigerant charge (lb-oz)	6-0	9-0	8-8	9-4	11-3	12-0
Dimensions (inches)						
Length	51-1/4	51-1/4	51-1/4	51-1/4	51-1/4	51-1/4
Width	35-3/4	35-3/4	35-3/4	35-3/4	45-3/4	45-3/4
Height	47	47	47	49	49	51
Operating WT. (lbs.)	330	376	382	466	455	472
Compressors						
Type	Scroll	Scroll	Scroll	Scroll	Scroll	Scroll
Outdoor Coil Data						
Face area (Sq. Ft.)	15.1	15.1	15.1	16.9	19.5	21.5
Rows	1	2	2	2	2	2
Fins per inch	22	22	22	22	22	22
Tube diameter	3/8	3/8	3/8	3/8	3/8	3/8
Circuitry Type	Interlaced	Interlaced	Interlaced	Interlaced	Interlaced	Interlaced
Indoor Coil Data						
Face area (Sq. Ft.)	4.6	4.6	4.6	4.6	6.3	6.3
Rows	2	3	3	3	3	3
Fins per inch	16	16	16	16	16	16
Tube diameter	3/8	3/8	3/8	3/8	3/8	3/8
Circuitry Type	Interlaced	Interlaced	Interlaced	Interlaced	Interlaced	Interlaced
Refrigerant control	TXV	TXV	TXV	TXV	TXV	TXV
Outdoor Fan Data						
Fan diameter (Inch)	24	24	24	24	26	26
Type	Prop	Prop	Prop	Prop	Prop	Prop
Drive type	Direct	Direct	Direct	Direct	Direct	Direct
No. speeds	1	1	1	1	1	1
Motor HP each	1/4	1/4	1/4	1/4	1/3	1/3
RPM	850	850	850	850	850	850
Nominal total CFM	2400	2400	2400	2400	3200	3200
Direct Drive Indoor Fan Data						
Fan Size (Inch)	11 x 8	11 x 8	11 x 10	11 x 10	11 x 10	11 x 10
Type	Centrifugal	Centrifugal	Centrifugal	Centrifugal	Centrifugal	Centrifugal
Motor HP each	1/2	1/2	1/2	3/4	3/4	1
RPM	1200 Max	1200 Max	1200 Max	1200 Max	1200 Max	1200 Max
Frame size	48	48	48	48	48	48
Filters						
Filter Size	A	A	A	A	B	B
Quantity - Size	Field-supplied external filters must be sized so as not to exceed 300 fpm air velocity through disposable filters. For internal filter use, a filter rack kit is available. Consult the instructions supplied with that kit for replacement filter sizes. A=20 x 20, B=20 x 30					

COOLING PERFORMANCE DATA - 3 TON																
PACKAGED UNIT MODEL NO.		PCE4A3622														
CONDENSER ENTERING AIR TEMPERATURE	ID CFM	1400					1200					1000				
	IDDB	80	80	75	80	80	80	80	75	80	80	80	80	75	80	80
	IDWB	57	62	62	67	72	57	62	62	67	72	57	62	62	67	72
55 / 45	T.C.	36.0	38.3	40.3	44.9	48.1	38.9	40.4	42.1	46.8	49.8	41.8	42.5	43.9	48.8	51.5
	S.C.	34.5	30.6	27.6	27.9	22.6	37.1	33.8	29.9	30.2	23.9	39.6	37.1	32.2	32.5	25.1
	K.W.	1.82	1.83	1.83	1.83	1.85	1.89	1.90	1.90	1.91	1.92	1.97	1.97	1.98	1.99	1.99
65 / 55	T.C.	34.6	36.4	37.4	42.6	46.1	37.3	38.3	39.4	44.2	47.9	40.0	40.2	41.3	45.9	49.8
	S.C.	33.2	29.8	26.0	26.8	21.6	35.6	32.9	28.5	28.9	23.4	37.9	36.1	31.0	31.1	25.1
	K.W.	2.01	2.02	2.02	2.03	2.04	2.09	2.09	2.09	2.10	2.11	2.16	2.16	2.17	2.18	2.19
75 / 63	T.C.	33.2	34.6	34.5	40.3	44.0	35.7	36.3	36.6	41.7	46.1	38.1	37.9	38.7	43.1	48.2
	S.C.	32.0	28.9	24.5	25.7	20.7	34.1	32.0	27.2	27.7	22.9	36.1	35.2	29.9	29.7	25.0
	K.W.	2.20	2.20	2.21	2.22	2.23	2.28	2.28	2.28	2.30	2.30	2.36	2.36	2.36	2.37	2.38
85 / 69	T.C.	31.7	32.6	32.2	37.8	41.2	34.0	34.0	33.8	38.9	42.8	36.3	35.4	35.4	40.1	44.5
	S.C.	30.4	26.9	23.3	24.6	19.3	32.4	30.3	25.8	26.5	21.1	34.5	33.7	28.2	28.4	22.8
	K.W.	2.46	2.44	2.47	2.48	2.49	2.53	2.53	2.54	2.55	2.56	2.61	2.61	2.61	2.63	2.63
95 / 75	T.C.	30.1	30.6	29.8	35.3	38.4	32.3	31.7	31.0	36.2	39.6	34.5	32.8	32.1	37.1	40.8
	S.C.	28.8	25.0	22.2	23.4	17.9	30.8	28.6	24.3	25.3	19.3	32.8	32.2	26.5	27.2	20.7
	K.W.	2.72	2.67	2.73	2.74	2.74	2.79	2.77	2.80	2.81	2.82	2.87	2.87	2.87	2.88	2.89
105 / 83	T.C.	29.0	28.3	27.8	32.8	36.1	31.1	29.6	28.9	33.8	37.1	33.3	30.8	29.9	34.7	38.1
	S.C.	27.5	23.9	20.9	21.8	16.9	29.4	27.1	22.9	23.8	18.2	31.3	30.4	25.0	25.8	19.6
	K.W.	2.91	2.92	2.95	2.96	2.97	2.95	3.01	3.02	3.04	3.05	2.98	3.10	3.10	3.11	3.12
115 / 89	T.C.	27.9	26.0	25.9	30.4	33.9	30.0	27.4	26.8	31.4	34.7	32.1	28.9	27.8	32.3	35.5
	S.C.	26.3	22.9	19.6	20.3	15.9	28.1	25.8	21.6	22.3	17.2	29.9	28.6	23.5	24.4	18.5
	K.W.	3.11	3.16	3.17	3.19	3.20	3.10	3.24	3.24	3.26	3.27	3.10	3.32	3.32	3.33	3.35
125 / 95	T.C.	26.8	23.8	24.0	28.0	31.7	28.9	25.3	24.8	29.0	32.3	31.0	26.9	25.6	30.0	33.0
	S.C.	25.1	21.9	18.3	18.7	14.9	26.8	24.4	20.2	20.9	16.2	28.5	26.9	22.1	23.1	17.4
	K.W.	3.30	3.39	3.39	3.41	3.42	3.25	3.47	3.46	3.48	3.49	3.21	3.55	3.54	3.55	3.57

COOLING PERFORMANCE DATA - 3.5 TON																
PACKAGED UNIT MODEL NO.		PCE4A4221														
CONDENSER ENTERING AIR TEMPERATURE	ID CFM	1600					1400					1200				
	IDDB	80	80	75	80	80	80	80	75	80	80	80	80	75	80	80
	IDWB	57	62	62	67	72	57	62	62	67	72	57	62	62	67	72
55 / 45	T.C.	43.7	46.9	46.8	51.8	57.3	46.5	48.6	48.5	53.7	59.6	49.4	50.2	50.2	55.5	61.9
	S.C.	43.1	39.2	33.9	34.4	28.7	45.5	42.1	36.2	37.0	30.7	47.8	45.0	38.5	39.6	32.6
	K.W.	2.35	2.36	2.36	2.38	2.38	2.42	2.44	2.43	2.45	2.47	2.50	2.52	2.51	2.53	2.56
65 / 55	T.C.	42.2	44.1	44.1	48.9	54.1	44.4	45.6	45.6	50.5	56.1	46.6	47.0	47.0	52.1	58.0
	S.C.	41.9	37.7	32.5	32.8	27.5	43.7	40.5	34.4	35.3	29.2	45.5	43.2	36.4	37.7	30.8
	K.W.	2.36	2.61	2.59	2.62	2.61	2.55	2.68	2.66	2.70	2.71	2.73	2.76	2.74	2.77	2.80
75 / 63	T.C.	40.6	41.3	41.4	46.0	51.0	42.2	42.6	42.6	47.4	52.5	43.8	43.9	43.7	48.7	54.1
	S.C.	40.6	36.3	31.0	31.3	26.2	41.9	38.8	32.7	33.6	27.6	43.3	41.4	34.3	35.9	29.0
	K.W.	2.38	2.86	2.82	2.87	2.84	2.67	2.93	2.89	2.94	2.94	2.97	3.00	2.97	3.01	3.04
85 / 69	T.C.	38.0	38.2	38.4	42.7	47.6	39.3	40.0	39.3	43.8	48.8	40.7	41.8	40.1	44.9	50.0
	S.C.	38.0	34.5	29.3	28.5	24.5	39.2	36.1	31.0	31.2	25.9	40.4	37.7	32.8	33.9	27.3
	K.W.	2.69	3.17	3.13	3.18	3.15	2.98	3.24	3.20	3.24	3.26	3.28	3.30	3.28	3.31	3.36
95 / 75	T.C.	35.4	35.1	35.4	39.3	44.1	36.5	37.4	35.9	40.2	45.1	37.6	39.7	36.5	41.1	46.0
	S.C.	35.4	32.7	27.6	25.8	22.8	36.5	33.3	29.4	28.9	24.1	37.6	33.9	31.3	32.0	25.5
	K.W.	3.00	3.48	3.44	3.48	3.47	3.29	3.54	3.51	3.54	3.57	3.59	3.60	3.59	3.60	3.67
105 / 83	T.C.	31.7	31.2	31.2	34.9	39.4	32.5	33.0	31.5	35.5	40.0	33.3	34.8	31.8	36.1	40.6
	S.C.	31.7	29.6	25.4	24.5	20.9	32.5	30.3	26.9	27.0	22.1	33.3	31.0	28.4	29.5	23.3
	K.W.	3.44	3.90	3.86	3.90	3.90	3.72	3.97	3.94	3.97	3.99	4.01	4.03	4.01	4.03	4.09
115 / 89	T.C.	28.2	27.4	27.1	30.7	34.7	28.7	28.8	27.2	30.9	35.0	29.2	30.1	27.3	31.1	35.3
	S.C.	28.2	26.7	23.3	23.1	19.0	28.7	27.4	24.4	25.2	20.1	29.2	28.2	25.6	27.2	21.2
	K.W.	3.86	4.31	4.28	4.30	4.31	4.14	4.38	4.35	4.37	4.41	4.43	4.45	4.42	4.45	4.50
125 / 95	T.C.	24.7	23.7	23.0	26.5	30.1	24.9	24.5	22.9	26.4	30.1	25.1	25.4	22.8	26.2	30.1
	S.C.	24.7	23.7	21.2	21.8	17.2	24.9	24.5	22.0	23.3	18.1	25.1	25.4	22.8	24.8	19.1
	K.W.	4.29	4.71	4.69	4.70	4.73	4.57	4.79	4.76	4.78	4.82	4.84	4.86	4.83	4.87	4.91

COOLING PERFORMANCE DATA - 4 TON																	
PACKAGED UNIT MODEL NO.		PCE4B4822															
CONDENSER ENTERING AIR TEMPERATURE	ID CFM	1800					1600					1400					
		IDDB	80	80	75	80	80	80	80	75	80	80	80	80	75	80	80
		IDWB	57	62	62	67	72	57	62	62	67	72	57	62	62	67	72
55 / 45	T.C.	50.7	55.0	54.4	59.4	65.3	53.0	56.8	56.1	61.2	67.2	55.4	58.6	57.9	63.1	69.1	
	S.C.	48.2	44.8	38.3	38.5	30.4	49.3	48.2	41.0	40.7	31.9	50.3	51.5	43.6	42.9	33.4	
	K.W.	2.48	2.52	2.51	2.54	2.56	2.56	2.59	2.58	2.61	2.62	2.64	2.65	2.64	2.67	2.68	
65 / 55	T.C.	48.0	52.0	51.2	57.1	62.8	50.3	53.6	52.9	58.7	64.4	52.5	55.2	54.5	60.3	66.0	
	S.C.	44.3	43.2	36.7	37.1	29.6	46.3	46.6	39.3	39.4	30.8	48.4	50.0	41.9	41.7	32.1	
	K.W.	2.76	2.79	2.79	2.81	2.83	2.83	2.85	2.85	2.88	2.89	2.90	2.92	2.91	2.94	2.95	
75 / 63	T.C.	45.4	49.0	48.1	54.9	60.3	47.5	50.4	49.6	56.2	61.6	49.6	51.8	51.1	57.5	62.9	
	S.C.	40.3	41.7	35.0	35.7	28.7	43.4	45.1	37.6	38.1	29.7	46.4	48.4	40.2	40.5	30.8	
	K.W.	3.04	3.06	3.06	3.08	3.11	3.10	3.12	3.12	3.14	3.17	3.16	3.18	3.18	3.21	3.23	
85 / 69	T.C.	42.9	45.4	44.9	51.3	56.4	44.8	46.6	46.1	52.5	57.7	46.7	47.7	47.2	53.6	59.1	
	S.C.	38.3	39.8	33.2	33.7	27.3	41.4	42.4	35.7	36.3	28.4	44.4	44.9	38.2	38.9	29.4	
	K.W.	3.41	3.42	3.42	3.44	3.46	3.47	3.49	3.48	3.50	3.53	3.53	3.55	3.54	3.57	3.59	
95 / 75	T.C.	40.4	41.8	41.7	47.7	52.4	42.1	42.7	42.6	48.7	53.8	43.9	43.6	43.4	49.7	55.2	
	S.C.	36.4	38.0	31.4	31.8	25.9	39.4	39.7	33.8	34.5	27.0	42.4	41.4	36.2	37.3	28.1	
	K.W.	3.79	3.79	3.78	3.80	3.82	3.85	3.85	3.83	3.86	3.89	3.90	3.91	3.89	3.92	3.95	
105 / 83	T.C.	36.7	37.6	37.5	43.5	47.8	38.1	38.4	38.0	44.3	48.9	39.5	39.2	38.6	45.1	50.0	
	S.C.	32.3	34.7	29.7	30.0	23.9	34.3	36.1	31.1	32.6	24.9	36.4	37.4	32.6	35.1	26.0	
	K.W.	4.30	4.30	4.29	4.32	4.34	4.36	4.36	4.35	4.38	4.41	4.43	4.42	4.41	4.44	4.47	
115 / 89	T.C.	33.1	33.6	33.3	39.4	43.4	34.1	34.3	33.6	40.0	44.2	35.2	35.0	33.8	40.6	45.0	
	S.C.	28.4	31.6	28.0	28.4	21.9	29.4	32.5	28.6	30.7	22.9	30.5	33.5	29.1	33.0	23.9	
	K.W.	4.80	4.80	4.79	4.83	4.85	4.87	4.86	4.86	4.89	4.91	4.93	4.92	4.92	4.95	4.97	
125 / 95	T.C.	29.5	29.5	29.2	35.3	39.0	30.2	30.1	29.2	35.7	39.5	30.9	30.7	29.1	36.1	40.0	
	S.C.	24.5	28.4	26.4	26.7	19.9	24.5	29.0	26.0	28.8	20.9	24.6	29.6	25.6	31.0	21.9	
	K.W.	5.30	5.29	5.30	5.33	5.35	5.37	5.36	5.36	5.39	5.41	5.44	5.42	5.42	5.45	5.47	

COOLING PERFORMANCE DATA - 5 TON																	
PACKAGED UNIT MODEL NO.		PCE4B6022															
CONDENSER ENTERING AIR TEMPERATURE	ID CFM	2050					1800					1550					
		IDDB	80	80	75	80	80	80	80	75	80	80	80	80	75	80	80
		IDWB	57	62	62	67	72	57	62	62	67	72	57	62	62	67	72
55 / 45	T.C.	68.0	69.1	68.1	73.0	79.5	70.4	70.4	69.3	74.8	80.8	72.7	71.7	70.5	76.6	82.2	
	S.C.	63.3	54.8	46.2	43.7	36.0	66.7	57.0	48.8	46.3	37.1	70.1	59.2	51.4	48.8	38.2	
	K.W.	2.93	2.97	2.97	3.00	3.03	3.15	3.17	3.18	3.21	3.24	3.36	3.38	3.38	3.42	3.45	
65 / 55	T.C.	64.1	65.4	64.3	69.7	75.7	66.2	66.4	65.1	71.0	76.5	68.4	67.5	65.9	72.3	77.4	
	S.C.	60.3	53.4	44.6	43.2	34.9	62.8	55.9	46.7	45.4	35.7	65.3	58.3	48.9	47.6	36.5	
	K.W.	3.25	3.27	3.28	3.31	3.35	3.46	3.48	3.49	3.52	3.56	3.68	3.69	3.69	3.73	3.77	
75 / 63	T.C.	60.2	61.8	60.5	66.4	72.0	62.1	62.5	60.9	67.1	72.2	64.0	63.2	61.4	67.9	72.5	
	S.C.	57.4	52.0	43.1	42.7	33.7	59.0	54.7	44.7	44.5	34.3	60.6	57.5	46.3	46.3	34.9	
	K.W.	3.56	3.58	3.59	3.63	3.67	3.78	3.79	3.80	3.84	3.88	3.99	4.00	4.01	4.04	4.08	
85 / 69	T.C.	57.4	57.1	56.2	61.8	67.1	58.7	57.8	56.6	62.3	67.4	60.0	58.4	57.0	62.9	67.7	
	S.C.	55.0	49.4	41.1	40.5	31.6	56.2	52.2	43.1	42.5	32.8	57.5	55.0	45.1	44.5	33.9	
	K.W.	3.98	4.00	4.01	4.04	4.07	4.19	4.21	4.21	4.24	4.28	4.41	4.42	4.42	4.45	4.48	
95 / 75	T.C.	54.5	52.4	52.0	57.1	62.3	55.3	53.0	52.3	57.5	62.6	56.1	53.7	52.5	57.9	62.9	
	S.C.	52.6	46.9	39.2	38.2	29.4	53.5	49.7	41.5	40.4	31.2	54.4	52.5	43.8	42.6	33.0	
	K.W.	4.40	4.42	4.42	4.44	4.48	4.61	4.62	4.62	4.65	4.68	4.82	4.83	4.83	4.86	4.88	
105 / 83	T.C.	52.1	47.2	45.9	51.1	55.2	52.5	47.6	45.6	51.0	55.2	52.8	47.9	45.2	50.9	55.1	
	S.C.	49.5	42.1	36.3	36.0	26.7	50.0	44.0	37.3	37.8	28.1	50.4	45.8	38.3	39.7	29.5	
	K.W.	5.03	4.99	4.99	5.01	5.05	5.22	5.19	5.19	5.22	5.25	5.40	5.40	5.40	5.42	5.45	
115 / 89	T.C.	49.8	42.2	40.0	45.3	48.3	49.8	42.3	39.0	44.7	47.9	49.7	42.3	38.1	44.0	47.5	
	S.C.	46.6	37.5	33.4	33.8	24.0	46.6	38.4	33.3	35.3	25.0	46.6	39.4	33.1	36.9	26.0	
	K.W.	5.65	5.54	5.54	5.57	5.60	5.80	5.75	5.74	5.77	5.80	5.96	5.95	5.95	5.97	6.00	
125 / 95	T.C.	47.5	37.1	34.1	39.5	41.4	47.1	36.9	32.5	38.3	40.7	46.6	36.8	31.0	37.2	39.9	
	S.C.	43.6	32.8	30.6	31.6	21.3	43.1	32.9	29.2	32.8	21.9	42.7	32.9	27.8	34.1	22.6	
	K.W.	6.27	6.09	6.09	6.12	6.15	6.39	6.30	6.30	6.32	6.35	6.52	6.51	6.50	6.52	6.55	

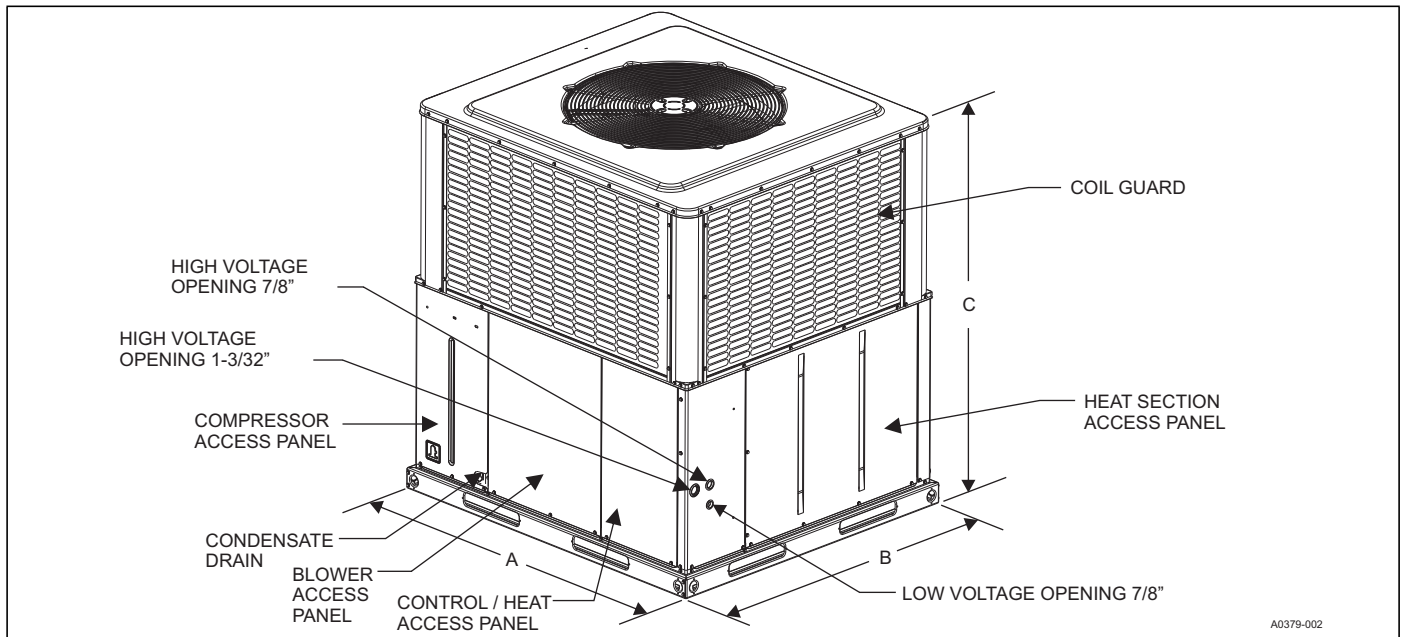

UNIT DIMENSIONS AND ACCESS LOCATIONS

Model	Dimensions - in inches		
	A	B	C
PCE4A2422	51-1/4	35-3/4	47
PCE4A3022	51-1/4	35-3/4	47
PCE4A3622	51-1/4	35-3/4	47
PCE4A4221	51-1/4	35-3/4	49
PCE4B4822	51-1/4	45-3/4	49
PCE4B6022	51-1/4	45-3/4	51

UNIT CLEARANCES¹

Direction	Distance (in.)	Direction	Distance (in.)
Top ²	36	Power Entry (Right Side)	36
Side Opposite Ducts	36	Left Side	24
Duct Panel	0	Bottom ³	1

1. A 1" clearance must be provided between any combustible material and the supply air duct work.
2. Units must be installed outdoors. Overhanging structures or shrubs must not obstruct condenser air discharge outlet.
3. Units may be installed on combustible materials made from wood or class A, B or C roof covering materials only if factory base rails are left in place as shipped.

ELECTRIC HEAT MINIMUM SUPPLY AIR

Model	Voltage	Minimum Blower Speed for Electric Heat								
		Heater kW								
		2	5	8	10	13	15	18	20	25
PCE4A2422	208/230-1-60	Low #1	Low #1	Med. Low #2	Med. #3	Med. Hi #4	--	--	--	--
PCE4A3022	208/230-1-60	Low #1	Low #1	Low #1	Med. Low #2	Med #3	High #5	--	--	--
PCE4A3622	208/230-1-60	Low #1	Low #1	Low #1	Low #1	Med. Low #2	High #5	--	--	--
PCE4A4221	208/230-1-60	--	Low #1	Low #1	Low #1	Low #1	Med. Low #2	Med. Hi #4	High #5	--
PCE4B4822	208/230-1-60	--	Low #1	Low #1	Low #1	Low #1	Low #1	Med. Low #2	Med. High #4	--
PCE4B6022	208/230-1-60	--	Low #1	Low #1	Low #1	Low #1	Low #1	Low #1	Med. Low #2	Med. High #4

INDOOR BLOWER SPECIFICATIONS

Model	Motor				
	HP	RPM	EFF.	SF	Frame
PCE4A2422	1/2	Variable	0.8	1.0	48
PCE4A3022	1/2	Variable	0.8	1.0	48
PCE4A3622	1/2	Variable	0.8	1.0	48
PCE4A4221	3/4	Variable	0.8	1.0	48
PCE4B4822	3/4	Variable	0.8	1.0	48
PCE4B6022	1	Variable	0.8	1.0	48

SOUND PERFORMANCE

Model (Tons)	Sound Rating ¹ dB (A)	Octave Band Centerline Frequency (Hz)						
		125	250	500	1000	2000	4000	8000
PCE4A2422	75	62.4	61.5	64.2	67.0	61.0	57.3	49.6
PCE4A3022	75	60.5	61.6	64.8	66.9	60.9	56.0	49.7
PCE4A3622	74	58.5	61.8	65.4	66.5	60.7	54.8	49.8
PCE4A4221	74	63.5	63.9	62.3	65.0	64.0	54.1	46.6
PCE4B4822	74	63.5	63.9	62.3	65.0	64.0	54.1	46.6
PCE4B6022	76	72.3	65.0	63.9	64.0	60.0	55.5	49.0

1. Rated in accordance with AHRI Standard 270.

**ELECTRICAL DATA - 208/230-1-60 SINGLE SOURCE POWER
SINGLE POINT CONNECTION KIT REQUIRED**

Model	Compressor			OD Fan Motor	Blower Motor	Electric Heat Option					MCA ¹ (Amps)		Max Fuse ² or Breaker ³ Size		
	RLA	LRA	MCC	FLA	FLA	Heater Kit	Heater kW		Stages	Heater Amps		208	230	208	230
							208	230		208	230				
A24	13	58	20	0.7	3.8	none	--	--	--	--	--	20.5	20.5	30	30
						6HK16500206	1.8	2.2	1	8.7	9.6	20.5	20.5	30	30
						6HK16500506	3.6	4.4	1	17.3	19.1	25.5	27.8	30	30
						6HK16500806	5.8	7.1	1	27.9	30.9	38.5	42.1	40	45
						6HK16501006	7.2	8.8	1	34.6	38.3	47.1	51.7	50	60
						6HK16501306	9.4	11.5	2	45.2	50.0	60.1	66.1	70	70
A30	14	73	22	0.8	3.8	none	--	--	--	--	--	22.2	22.2	35	35
						6HK16500206	1.8	2.2	1	8.7	9.6	22.2	22.2	35	35
						6HK16500506	3.6	4.4	1	17.3	19.1	25.5	27.8	35	35
						6HK16500806	5.8	7.1	1	27.9	30.9	38.5	42.1	40	45
						6HK16501006	7.2	8.8	1	34.6	38.3	47.1	51.7	50	60
						6HK16501306	9.4	11.5	2	45.2	50.0	60.1	66.1	70	70
A36	17	79	26	1.3	3.8	none	--	--	--	--	--	26.0	26.0	40	40
						6HK16500206	1.8	2.2	1	8.7	9.6	26.0	26.0	40	40
						6HK16500506	3.6	4.4	1	17.3	19.1	25.5	27.8	40	40
						6HK16500806	5.8	7.1	1	27.9	30.9	38.5	42.1	40	45
						6HK16501006	7.2	8.8	1	34.6	38.3	47.1	51.7	50	60
						6HK16501306	9.4	11.5	2	45.2	50.0	60.1	66.1	70	70
A42	18	112	28	1.3	5.4	none	--	--	--	--	--	29.1	29.1	45	45
						6HK16500506	3.6	4.4	1	17.3	19.1	29.1	29.4	45	45
						6HK16500806	5.8	7.1	1	27.9	30.9	40.1	43.7	45	45
						6HK16501006	7.2	8.8	1	34.6	38.3	48.7	53.3	50	60
						6HK16501306	9.4	11.5	2	45.2	50.0	61.7	67.7	70	70
						6HK16501506	10.8	13.2	2	51.9	57.4	70.4	77.3	80	80
						6HK16501806	13.0	15.9	2	62.5	69.1	83.4	91.7	90	100
6HK16502006	14.4	17.6	2	69.2	76.5	92.1	101.2	100	110						

**ELECTRICAL DATA - 208/230-1-60 SINGLE SOURCE POWER
SINGLE POINT CONNECTION KIT REQUIRED**

Model	Compressor			OD Fan Motor	Blower Motor	Electric Heat Option					MCA ¹ (Amps)		Max Fuse ² or Breaker ³ Size		
						Heater Kit	Heater kW		Stages	Heater Amps		208	230	208	230
	RLA	LRA	MCC	FLA	FLA		208	230							
B48	22	117	34	1.7	5.4	none	--	--	--	--	--	34.4	34.4	50	50
						6HK16500506	3.6	4.4	1	17.3	19.1	34.4	34.4	50	50
						6HK16500806	5.8	7.1	1	27.9	30.9	40.1	43.7	50	50
						6HK16501006	7.2	8.8	1	34.6	38.3	48.7	53.3	50	60
						6HK16501306	9.4	11.5	2	45.2	50.0	61.7	67.7	70	70
						6HK16501506	10.8	13.2	2	51.9	57.4	70.4	77.3	80	80
						6HK16501806	13.0	15.9	2	62.5	69.1	83.4	91.7	90	100
B60	24	144	38	1.7	7.0	none	--	--	--	--	--	39.2	39.2	60	60
						6HK16500506	3.6	4.4	1	17.3	19.1	39.2	39.2	60	60
						6HK16500806	5.8	7.1	1	27.9	30.9	41.7	45.3	60	60
						6HK16501006	7.2	8.8	1	34.6	38.3	50.3	54.9	60	60
						6HK16501306	9.4	11.5	2	45.2	50.0	63.3	69.3	70	70
						6HK16501506	10.8	13.2	2	51.9	57.4	72.0	78.9	80	80
						6HK16501806	13.0	15.9	2	62.5	69.1	85.0	93.3	90	100
						6HK16502006	14.4	17.6	2	69.2	76.5	93.7	102.8	100	110
6HK165002506	18.0	22.0	2	86.7	95.8	115.3	126.8	125	150						

1. Minimum Circuit Ampacity.
2. Maximum Over Current Protection per standard UL 1995.
3. Fuse or HACR circuit breaker size installed at factory or field installed.

ELECTRICAL DATA FOR - 208-1-60 MULTI SOURCE POWER

Model	Compressor			OD Fan Motor	Blower Motor	Electric Heat Option				Multi Source							
						Heater Kit	Heater kW	Stages	Heater Amps								
	RLA	LRA	MCC	FLA	FLA					208	208	208	208	208	208	208	208
Multi Source: Compressor Circuit and Heat Circuits						Circuit #1 Compressor Circuit											
						Circuit #2 Heat				MCA ¹ Amps	MOP ²	MCA ¹ Amps	MOP ²	MCA ¹ Amps	MOP ²	MCA ¹ Amps	MOP ²
						Circuit #3 Heat				Circuit #1		Circuit #2		Circuit #3		Circuit #4	
						Circuit #4 Heat											
A24	12.8	58.3	20.0	0.7	3.8	none	--	--	--	20.5	30	--	--	--	--	--	
						6HK(0,1)6500206	1.8	1	8.7	20.5	30	10.8	15	--	--	--	--
						6HK(0,1)6500506	3.6	1	17.3	20.5	30	21.7	25	--	--	--	--
						6HK(0,1)6500806	5.8	1	27.7	20.5	30	34.7	35	--	--	--	--
						6HK(0,1)6501006	7.2	1	34.7	20.5	30	43.3	45	--	--	--	--
						6HK16501306	9.4	2	45.1	20.5	30	18.8	20	37.6	40	--	--
						6HK26501306	9.4	1	45.1	20.5	30	56.3	60	--	--	--	--
A30	14.1	73.0	22.0	0.8	3.8	none	--	--	--	22.2	35	--	--	--	--	--	
						6HK(0,1)6500206	1.8	1	8.7	22.2	35	10.8	15	--	--	--	--
						6HK(0,1)6500506	3.6	1	17.3	22.2	35	21.6	25	--	--	--	--
						6HK(0,1)6500806	5.8	1	27.9	22.2	35	34.9	35	--	--	--	--
						6HK(0,1)6501006	7.2	1	34.6	22.2	35	43.3	45	--	--	--	--
						6HK16501306	9.4	2	45.1	22.2	35	18.8	20	37.6	40	--	--
						6HK16501506	10.8	2	52.0	22.2	35	21.7	60	43.3	45	--	--
						6HK26501306	9.4	1	45.1	22.2	35	56.3	60	--	--	--	--
6HK26501506	10.8	1	52.0	22.2	35	65.0	70	--	--	--	--						

For notes, see Page 14.

ELECTRICAL DATA FOR - 208-1-60 MULTI SOURCE POWER (Continued)

Model	Compressor			OD Fan Motor	Blower Motor	Electric Heat Option				Multi Source								
	RLA	LRA	MCC	FLA	FLA	Heater Kit	Heater kW	Stages	Heater Amps	208	208	208	208	208	208	208		
							208		208									
Multi Source: Compressor Circuit and Heat Circuits						Multi Source:	Circuit #1 Compressor Circuit				MCA ¹ Amps	MOP ²	MCA ¹ Amps	MOP ²	MCA ¹ Amps	MOP ²	MCA ¹ Amps	MOP ²
							Circuit #2 Heat											
							Circuit #3 Heat											
							Circuit #4 Heat											
A36	16.7	79.0	26.0	1.3	3.8	none	--	--	--	26.0	40	--	--	--	--	--	--	
						6HK(0,1)6500206	1.8	1	8.7	26.0	40	10.8	15	--	--	--	--	
						6HK(0,1)6500506	3.6	1	17.3	26.0	40	21.6	25	--	--	--	--	
						6HK(0,1)6500806	5.8	1	27.9	26.0	40	34.9	35	--	--	--	--	
						6HK(0,1)6501006	7.2	1	34.6	26.0	40	43.3	45	--	--	--	--	
						6HK16501306	9.4	2	45.1	26.0	40	18.8	20	37.6	40	--	--	
						6HK16501506	10.8	2	52.0	26.0	40	21.7	60	43.3	45	--	--	
						6HK26501306	9.4	1	45.1	26.0	40	56.3	60	--	--	--	--	
						6HK26501506	10.8	1	52.0	26.0	40	65.0	70	--	--	--	--	
A42	17.9	112.0	28.0	1.3	5.4	none	--	1	--	29.1	45	--	--	--	--	--	--	
						6HK(0,1)6500506	3.6	1	17.3	29.1	45	21.7	25	--	--	--	--	
						6HK(0,1)6500806	5.8	1	27.7	29.1	45	34.7	35	--	--	--	--	
						6HK(0,1)6501006	7.2	1	34.7	29.1	45	43.3	45	--	--	--	--	
						6HK16501306	9.4	2	45.1	29.1	45	18.8	20	37.6	40	--	--	
						6HK16501506	10.8	2	52.0	29.1	45	21.7	25	43.3	45	--	--	
						6HK16501806	13.0	2	62.4	29.1	45	39.0	40	39.0	40	--	--	
						6HK16502006	14.4	2	69.3	29.1	45	43.3	45	43.3	45	--	--	
						6HK26501306	9.4	1	45.1	29.1	45	56.3	60	--	--	--	--	
						6HK26501506	10.8	1	52.0	29.1	45	65.0	70	--	--	--	--	
						6HK26501806	13.0	1	62.4	29.1	45	78.0	80	--	--	--	--	
B48	21.8	117.0	34.0	1.7	5.4	none	--	--	--	34.4	50	--	--	--	--	--	--	
						6HK(0,1)6500506	3.6	1	17.3	34.4	50	21.7	25	--	--	--	--	
						6HK(0,1)6500806	5.8	1	27.7	34.4	50	34.7	35	--	--	--	--	
						6HK(0,1)6501006	7.2	1	34.7	34.4	50	43.3	45	--	--	--	--	
						6HK16501306	9.4	2	45.1	34.4	50	18.8	20	37.6	40	--	--	
						6HK16501506	10.8	2	52.0	34.4	50	21.7	25	43.3	45	--	--	
						6HK16501806	13.0	2	62.4	34.4	50	39.0	40	39.0	40	--	--	
						6HK16502006	14.4	2	69.3	34.4	50	43.3	45	43.3	45	--	--	
						6HK26501306	9.4	1	45.1	34.4	50	56.3	60	--	--	--	--	
						6HK26501506	10.8	1	52.0	34.4	50	65.0	70	--	--	--	--	
						6HK26501806	13.0	1	62.4	34.4	50	78.0	80	--	--	--	--	
B60	24.4	144.2	38.0	1.7	7.0	none	--	--	--	39.2	60	--	--	--	--	--	--	
						6HK(0,1)6500506	3.6	1	17.3	39.2	60	21.7	25	--	--	--	--	
						6HK(0,1)6500806	5.8	1	27.7	39.2	60	34.7	35	--	--	--	--	
						6HK(0,1)6501006	7.2	1	34.7	39.2	60	43.3	45	--	--	--	--	
						6HK16501306	9.4	2	45.1	39.2	60	18.8	20	37.6	40	--	--	
						6HK16501506	10.8	2	52.0	39.2	60	21.7	25	43.3	45	--	--	
						6HK16501806	13.0	2	62.4	39.2	60	39.0	40	39.0	40	--	--	
						6HK16502006	14.4	2	69.3	39.2	60	43.3	45	43.3	45	--	--	
						6HK26501306	9.4	1	45.1	39.2	60	56.3	60	--	--	--	--	
						6HK26501506	10.8	1	52.0	39.2	60	65.0	70	--	--	--	--	
						6HK26501806	13.0	1	62.4	39.2	60	78.0	80	--	--	--	--	
						6HK26502006	14.4	1	69.3	39.2	60	86.7	90	--	--	--	--	
						6HK16502506	18.0	3	86.7	39.2	60	43.3	45	43.3	45	21.7	25	
6HK26502506	18.0	1	86.7	39.2	60	108.3	110	--	--	--	--							

1. MCA = Minimum Circuit Ampacity.
 2. MOP = Maximum Over Current Protection device; must be HACR type circuit breaker or time delay fuse.

ELECTRICAL DATA FOR 230-1-60 MULTI SOURCE POWER

Model	Compressor			OD Fan Motor	Blower Motor	Electric Heat Option				Multi Source												
	RLA	LRA	MCC	FLA	FLA	Heater Kit	Heater kW	Stages	Heater Amps	230	230	230	230	230	230	230						
							230		230													
Multi Source: Compressor Circuit and Heat Circuits						Multi Source:	Circuit #1 Compressor Circuit				MCA ¹ Amps	MOP ²	MCA ¹ Amps	MOP ²	MCA ¹ Amps	MOP ²	MCA ¹ Amps	MOP ²				
							Circuit #2 Heat												Circuit #1	Circuit #2	Circuit #3	Circuit #4
							Circuit #3 Heat															
							Circuit #4 Heat															
A24	12.8	58.3	20.0	0.7	3.8	none	--	--	--	20.5	30	--	--	--	--	--	--					
						6HK(0,1)6500206	2.2	1	9.6	20.5	30	12.0	15	--	--	--	--					
						6HK(0,1)6500506	4.4	1	19.2	20.5	30	24.0	25	--	--	--	--					
						6HK(0,1)6500806	7.1	1	30.7	20.5	30	38.3	40	--	--	--	--					
						6HK(0,1)6501006	8.8	1	38.3	20.5	30	47.9	50	--	--	--	--					
						6HK16501306	11.5	2	49.8	20.5	30	20.8	25	41.5	45	--	--					
						6HK26501306	11.5	1	49.8	20.5	30	62.3	70	--	--	--	--					
A30	14.1	73.0	22.0	0.8	3.8	none	--	--	--	22.2	35	--	--	--	--	--	--					
						6HK(0,1)6500206	2.2	1	9.6	22.2	35	12.0	15	--	--	--	--					
						6HK(0,1)6500506	4.4	1	19.1	22.2	35	23.9	25	--	--	--	--					
						6HK(0,1)6500806	7.1	1	30.9	22.2	35	38.6	40	--	--	--	--					
						6HK(0,1)6501006	8.8	1	38.3	22.2	35	47.8	50	--	--	--	--					
						6HK16501306	11.5	2	49.8	22.2	35	20.8	25	41.5	45	--	--					
						6HK16501506	13.2	2	57.5	22.2	35	24.0	70	47.9	50	--	--					
						6HK26501306	11.5	1	49.8	22.2	35	62.3	70	--	--	--	--					
6HK26501506	13.2	1	57.5	22.2	35	71.9	80	--	--	--	--											
A36	16.7	79.0	26.0	1.3	3.8	none	--	--	--	26.0	40	--	--	--	--	--	--					
						6HK(0,1)6500206	2.2	1	9.6	26.0	40	12.0	15	--	--	--	--					
						6HK(0,1)6500506	4.4	1	19.1	26.0	40	23.9	25	--	--	--	--					
						6HK(0,1)6500806	7.1	1	30.9	26.0	40	38.6	40	--	--	--	--					
						6HK(0,1)6501006	8.8	1	38.3	26.0	40	47.8	50	--	--	--	--					
						6HK16501306	11.5	2	49.8	26.0	40	20.8	25	41.5	45	--	--					
						6HK16501506	13.2	2	57.5	26.0	40	24.0	70	47.9	50	--	--					
						6HK26501306	11.5	1	49.8	26.0	40	62.3	70	--	--	--	--					
6HK26501506	13.2	1	57.5	26.0	40	71.9	80	--	--	--	--											
A42	17.9	112.0	28.0	1.3	5.4	none	--	1	--	29.1	45	--	--	--	--	--	--					
						6HK(0,1)6500506	4.4	1	19.1	29.1	45	23.9	25	--	--	--	--					
						6HK(0,1)6500806	7.1	1	30.9	29.1	45	38.6	40	--	--	--	--					
						6HK(0,1)6501006	8.8	1	38.3	29.1	45	47.8	50	--	--	--	--					
						6HK16501306	11.5	2	49.8	29.1	45	20.8	25	41.5	45	--	--					
						6HK16501506	13.2	2	57.5	29.1	45	24.0	25	47.9	50	--	--					
						6HK16501806	15.9	2	69.0	29.1	45	43.1	45	43.1	45	--	--					
						6HK16502006	17.6	2	76.7	29.1	45	47.9	50	47.9	50	--	--					
						6HK26501306	11.5	1	49.8	29.1	45	62.3	70	--	--	--	--					
						6HK26501506	13.2	1	57.5	29.1	45	71.9	80	--	--	--	--					
						6HK26501806	15.9	1	69.1	29.1	45	86.4	90	--	--	--	--					
6HK26502006	17.6	1	76.5	29.1	45	95.7	100	--	--	--	--											

For notes, see Page 16.

ELECTRICAL DATA FOR 230-1-60 MULTI SOURCE POWER

Model	Compressor			OD Fan Motor	Blower Motor	Electric Heat Option				Multi Source								
	RLA	LRA	MCC	FLA	FLA	Heater Kit	Heater kW	Stages	Heater Amps	230	230	230	230	230	230	230	230	
							230		230									
Multi Source: Compressor Circuit and Heat Circuits						Multi Source:	Circuit #1 Compressor Circuit				MCA ¹ Amps	MOP ²	MCA ¹ Amps	MOP ²	MCA ¹ Amps	MOP ²	MCA ¹ Amps	MOP ²
							Circuit #2 Heat											
							Circuit #3 Heat											
							Circuit #4 Heat											
B48	21.8	117.0	34.0	1.7	5.4	none	--	--	--	34.4	50	--	--	--	--	--	--	
						6HK(0,1)6500506	4.4	1	19.1	34.4	50	23.9	25	--	--	--	--	
						6HK(0,1)6500806	7.1	1	30.9	34.4	50	38.6	40	--	--	--	--	
						6HK(0,1)6501006	8.8	1	38.3	34.4	50	47.8	50	--	--	--	--	
						6HK16501306	11.5	2	49.8	34.4	50	20.8	25	41.5	45	--	--	
						6HK16501506	13.2	2	57.5	34.4	50	24.0	25	47.9	50	--	--	
						6HK16501806	15.9	2	69.0	34.4	50	43.1	45	43.1	45	--	--	
						6HK16502006	17.6	2	76.7	34.4	50	47.9	50	47.9	50	--	--	
						6HK26501306	11.5	1	49.8	34.4	50	62.3	70	--	--	--	--	
						6HK26501506	13.2	1	57.5	34.4	50	71.9	80	--	--	--	--	
						6HK26501806	15.9	1	69.1	34.4	50	86.4	90	--	--	--	--	
6HK26502006	17.6	1	76.5	34.4	50	95.7	100	--	--	--	--							
B60	24.4	144.2	38.0	1.7	7.0	none	--	--	--	39.2	60	--	--	--	--	--	--	
						6HK(0,1)6500506	4.4	1	19.1	39.2	60	23.9	25	--	--	--	--	
						6HK(0,1)6500806	7.1	1	30.9	39.2	60	38.6	40	--	--	--	--	
						6HK(0,1)6501006	8.8	1	38.3	39.2	60	47.8	50	--	--	--	--	
						6HK16501306	11.5	2	49.8	39.2	60	20.8	25	47.9	45	--	--	
						6HK16501506	13.2	2	57.5	39.2	60	24.0	25	47.9	50	--	--	
						6HK16501806	15.9	2	69.0	39.2	60	43.1	45	43.1	45	--	--	
						6HK16502006	17.6	2	76.7	39.2	60	47.9	50	47.9	50	--	--	
						6HK26501306	11.5	1	49.8	39.2	60	62.3	70	--	--	--	--	
						6HK26501506	13.2	1	57.5	39.2	60	71.9	80	--	--	--	--	
						6HK26501806	15.9	1	69.1	39.2	60	86.4	90	--	--	--	--	
						6HK26502006	17.6	1	76.5	39.2	60	95.7	100	--	--	--	--	
						6HK16502506	22.0	3	95.8	39.2	60	47.9	50	47.9	50	24	25	
6HK26502506	22.0	1	95.8	39.2	60	119.8	125	--	--	--	--							

1. MCA = Minimum Circuit Ampacity.
2. MOP = Maximum Over Current Protection device; must be HACR type circuit breaker or time delay fuse.

SINGLE-POINT WIRING KITS

NOTE:

For single circuit heater kits, remove the wires for the second circuit from the single-point block.

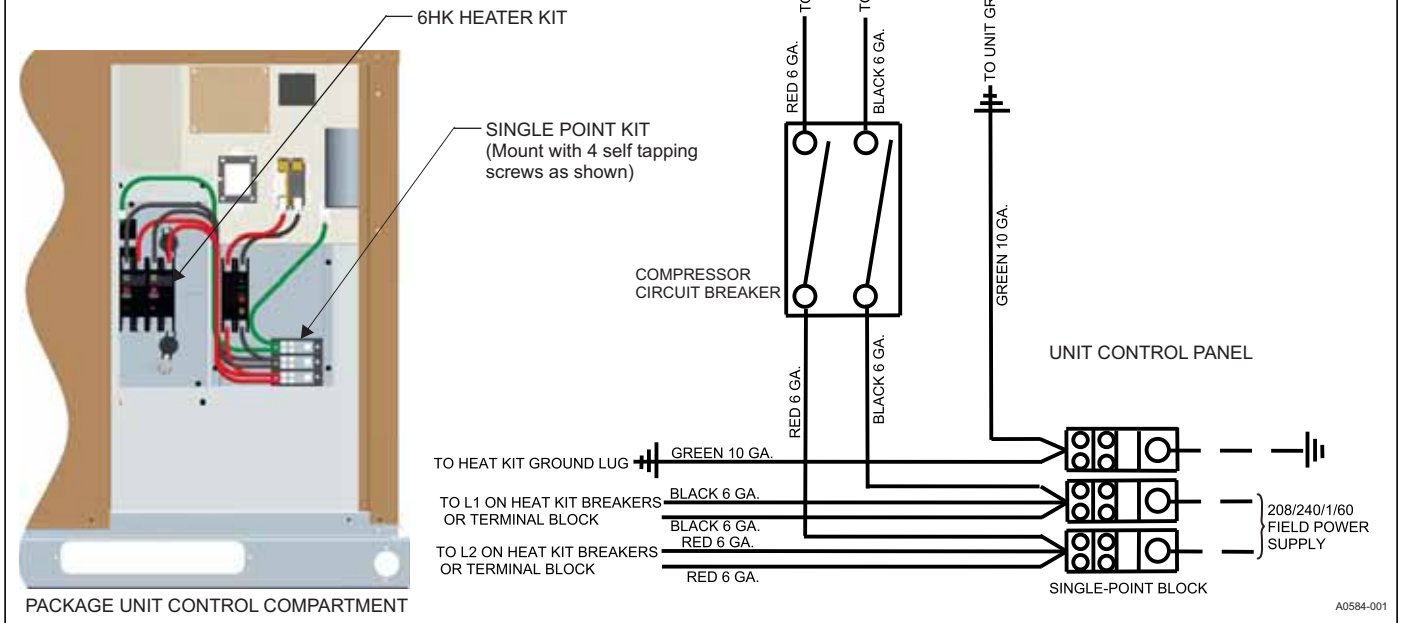

SINGLE-POINT WIRING KITS

Unit Model Number	Single Point Kit P/N	Breaker Size	Heat Kit
PCE4A24*	S1-2SPWK008	20 AMP	up to 13 kW
PCE4A30*	S1-2SPWK002	25 AMP	up to 15 kW
PCE4A36*	S1-2SPWK002	30 AMP	up to 15 kW
PCE4A24	S1-2SPWK001	30 AMP	up to 13 kW
PCE4A30	S1-2SPWK002	35 AMP	up to 15 kW
PCE4A36	S1-2SPWK007	40 AMP	up to 15 kW
PCE4A42	S1-2SPWK003	45 Amp	up to 20 kW
PCE4B48	S1-2SPWK004	50 Amp	up to 20 kW
PCE4B60	S1-2SPWK005	60 Amp	up to 20 kW
PHE4A24	S1-2SPWK006	25 Amp	up to 13 kW
PHE4A30	S1-2SPWK002	35 Amp	up to 15 kW
PHE4B36	S1-2SPWK007	40 Amp	up to 15 kW
PHE4B42	S1-2SPWK003	45 Amp	up to 20 kW
PHE4B48	S1-2SPWK004	50 Amp	up to 20 kW
PHE4B60	S1-2SPWK005	60 Amp	up to 20 kW

*Indicates models with reciprocating compressors

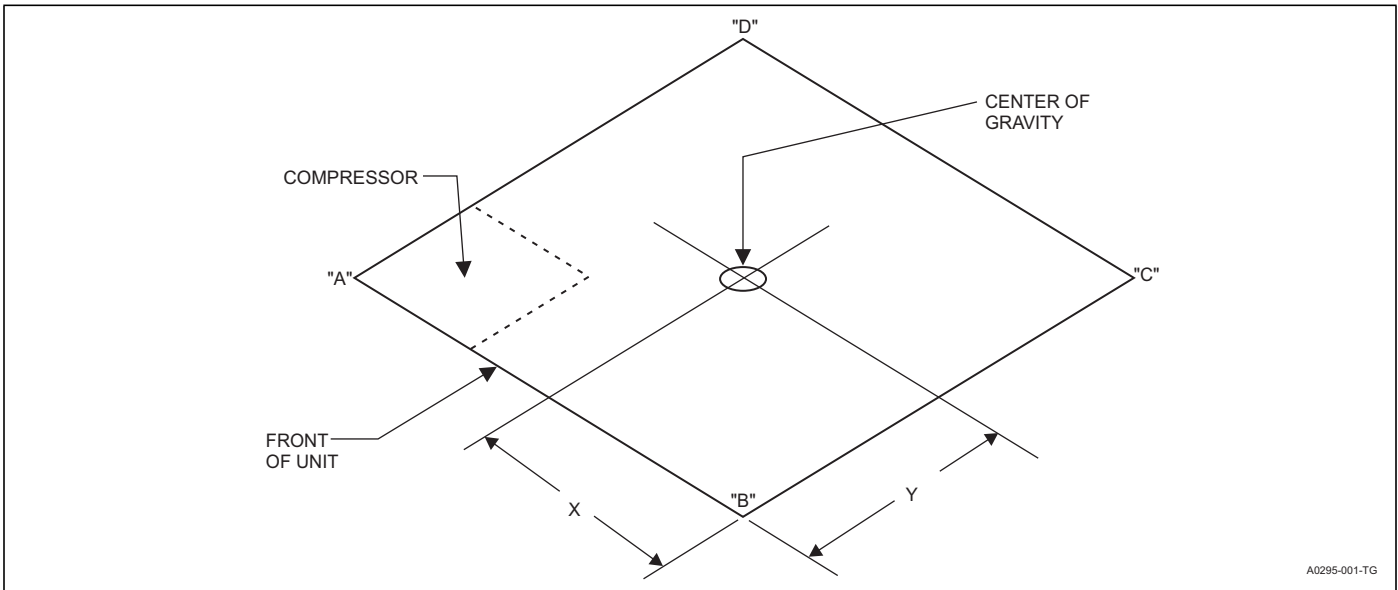

A0295-001-TG

WEIGHTS AND DIMENSIONS

Model	Weight (lbs.)		Center of Gravity		4 Point Load Location (lbs.)			
	Shipping	Operating	X	Y	A	B	C	D
PCE4A2422	335	330	30	15	96	105	107	40
PCE4A3022	381	376	30	15	107	123	123	41
PCE4A3622	387	382	30	15	112	123	120	45
PCE4A4221	471	466	32	13	169	132	131	39
PCE4B4822	460	455	30	19	158	125	130	75
PCE4B6022	477	472	30	20	157	134	140	74

AIRFLOW PERFORMANCE - SIDE DUCT APPLICATION

Model	Motor Speed	External Static Pressure (Inches WC)								
		0.1	0.2	0.3	0.4	0.5	0.6	0.7	0.8	1.0
		SCFM	SCFM	SCFM	SCFM	SCFM	SCFM	SCFM	SCFM	SCFM
PCE4A24	Low (1)	887	847	802	750	705	664	613	563	463
	Low/Medium (2)	978	941	898	850	803	759	713	667	575
	Medium (3)	1171	1114	1074	1039	993	949	906	864	780
	Medium/High (4)	1349	1297	1265	1224	1185	1146	1107	1063	975
	High (5)	1487	1462	1392	1331	1318	1281	1241	1201	1121
PCE4A30	Low (1)	1076	1020	984	943	903	859	819	779	699
	Low/Medium (2)	1102	1048	1010	974	934	890	850	810	730
	Medium (3)	1191	1140	1112	1076	1038	1000	958	919	841
	Medium/High (4)	1201	1225	1187	1151	1118	1080	1041	1002	924
	High (5)	1370	1329	1283	1271	1209	1176	1143	1109	1041
PCE4A36	Low (1)	1225	1174	1131	1090	1046	993	941	888	782
	Low/Medium (2)	1259	1209	1166	1126	1084	1032	980	928	824
	Medium (3)	1314	1271	1229	1186	1144	1097	1049	998	896
	Medium/High (4)	1348	1306	1259	1222	1179	1133	1086	1036	936
	High (5)	1506	1471	1403	1389	1345	1305	1262	1216	1124
PCE4A42	Low (1)	1436	1382	1342	1304	1262	1220	1179	1131	1035
	Low/Medium (2)	1544	1492	1455	1416	1376	1336	1294	1248	1156
	Medium (3)	1573	1523	1484	1445	1408	1367	1327	1279	1183
	Medium/High (4)	1681	1640	1599	1557	1517	1478	1436	1393	1307
	High (5)	1935	1887	1834	1788	1743	1701	1651	1591	1471
PCE4B48	Low (1)	1620	1564	1517	1466	1418	1360	1308	1206	1002
	Low/Medium (2)	1694	1630	1580	1530	1482	1430	1380	1292	1116
	Medium (3)	1798	1722	1669	1620	1572	1527	1480	1413	1280
	Medium/High (4)	1835	1758	1703	1653	1604	1558	1511	1442	1304
	High (5)	2146	2085	2025	1960	1872	1862	1798	1735	1609
PCE4B60	Low (1)	1730	1682	1628	1592	1552	1517	1479	1439	1359
	Low/Medium (2)	1858	1807	1749	1710	1667	1629	1589	1546	1460
	Medium (3)	2054	1998	1934	1890	1843	1801	1757	1710	1616
	Medium/High (4)	2195	2144	2098	2049	2003	1955	1883	1868	1838
	High (5)	2445	2388	2306	2293	2235	2178	2129	2077	1973

1. Airflow tested with dry coil conditions, without air filters, at 230 volts.
2. Applications above 0.8" w.c. external static pressure are not recommended.
3. Brushless DC high efficiency standard ECM blower motor used for all indoor blower assemblies.
4. Minimal variations in airflow performance data results from operating at 208 volts. Data above may be used in those cases.
5. Heating applications tested at 0.50" w.c. esp, and cooling applications tested at 0.30" w.c. esp per standards.

AIRFLOW PERFORMANCE - BOTTOM DUCT APPLICATION

Model	Motor Speed	External Static Pressure (Inches WC)								
		0.1	0.2	0.3	0.4	0.5	0.6	0.7	0.8	1.0
		SCFM	SCFM	SCFM	SCFM	SCFM	SCFM	SCFM	SCFM	SCFM
PCE4A24	Low (1)	899	869	827	782	734	685	630	575	465
	Low/Medium (2)	1033	960	924	879	834	787	735	685	585
	Medium (3)	1186	1133	1095	1056	1016	975	935	891	803
	Medium/High (4)	1357	1322	1284	1248	1211	1174	1127	1087	1007
	High (5)	1480	1439	1404	1367	1369	1299	1264	1226	1150
PCE4A30	Low (1)	1076	1042	1009	969	930	890	849	808	726
	Low/Medium (2)	1104	1063	1025	987	947	908	869	830	752
	Medium (3)	1205	1170	1136	1098	1060	1025	985	943	859
	Medium/High (4)	1285	1251	1213	1179	1141	1104	1065	1027	951
	High (5)	1406	1375	1341	1306	1271	1236	1198	1163	1093
PCE4A36	Low (1)	1231	1186	1146	1103	1069	1030	977	912	781
	Low/Medium (2)	1270	1225	1189	1140	1098	1046	1008	960	866
	Medium (3)	1317	1286	1245	1198	1151	1110	1064	1024	943
	Medium/High (4)	1358	1317	1275	1238	1197	1148	1105	1057	961
	High (5)	1517	1475	1447	1400	1357	1318	1275	1232	1146
PCE4A42	Low (1)	1455	1414	1379	1335	1294	1254	1212	1160	1056
	Low/Medium (2)	1566	1532	1492	1455	1416	1372	1333	1280	1174
	Medium (3)	1565	1530	1491	1458	1419	1381	1336	1290	1198
	Medium/High (4)	1675	1641	1606	1578	1535	1495	1455	1412	1326
	High (5)	1946	1909	1863	1815	1771	1721	1654	1595	1477
PCE4B48	Low (1)	1598	1548	1502	1454	1410	1362	1307	1251	1139
	Low/Medium (2)	1663	1612	1568	1522	1476	1422	1370	1297	1152
	Medium (3)	1789	1733	1670	1650	1596	1578	1535	1483	1379
	Medium/High (4)	1931	1814	1808	1736	1673	1650	1597	1519	1362
	High (5)	2131	2058	1998	1949	1892	1840	1788	1728	1608
PCE4B60	Low (1)	1655	1612	1596	1531	1461	1462	1429	1391	1316
	Low/Medium (2)	1766	1720	1667	1629	1632	1539	1537	1498	1421
	Medium (3)	1987	1933	1861	1817	1820	1715	1725	1651	1504
	Medium/High (4)	2114	2050	2047	1974	1899	1889	1920	1866	1758
	High (5)	2369	2308	2249	2183	2126	2088	2034	1990	1902

1. Airflow tested with dry coil conditions, without air filters, at 230 volts
2. Applications above 0.8" w.c. external static pressure are not recommended.
3. Brushless DC high efficiency standard ECM blower motor used for all indoor blower assemblies.
4. Minimal variations in airflow performance data results from operating at 208 volts. Data above may be used in those cases.
5. Heating applications tested at 0.50" w.c. esp, and cooling applications tested at 0.30" w.c. esp per standards.

ADDITIONAL STATIC RESISTANCE

Size (Tons)	CFM	Wet Indoor Coil	Economizer ¹	Filter/Frame Kit
24 (2.0)	500	0.01	0.00	0.01
	600	0.01	0.00	0.02
	700	0.01	0.00	0.04
	800	0.02	0.01	0.06
	900	0.03	0.01	0.08
	1000	0.04	0.01	0.10
	1100	0.05	0.01	0.13
	1200	0.06	0.02	0.16

ADDITIONAL STATIC RESISTANCE

Size (Tons)	CFM	Wet Indoor Coil	Economizer ¹	Filter/Frame Kit
30 (2.5)	700	0.01	0.00	0.04
	800	0.02	0.01	0.06
	900	0.03	0.01	0.08
	1000	0.04	0.01	0.10
	1100	0.05	0.01	0.13
	1200	0.06	0.02	0.16
	1300	0.07	0.03	0.17
	1400	0.08	0.04	0.18
36 (3.0)	700	0.01	0.00	0.04
	800	0.02	0.01	0.06
	900	0.03	0.01	0.08
	1000	0.04	0.01	0.10
	1100	0.05	0.01	0.13
	1200	0.06	0.02	0.16
	1300	0.07	0.03	0.17
	1400	0.08	0.04	0.18

ADDITIONAL STATIC RESISTANCE

Size (Tons)	CFM	Wet Indoor Coil	Economizer ¹	Filter/Frame Kit
42 (3.5)	1100	0.02	0.02	0.04
	1200	0.03	0.02	0.04
	1300	0.04	0.02	0.05
	1400	0.05	0.03	0.05
	1500	0.06	0.04	0.06
	1600	0.07	0.04	0.07
	1700	0.07	0.04	0.08
	1800	0.08	0.04	0.09
	1900	0.09	0.05	0.10
	2000	0.09	0.05	0.11
48 (4.0)	1100	0.02	0.02	0.04
	1200	0.03	0.02	0.04
	1300	0.04	0.02	0.05
	1400	0.05	0.03	0.05
	1500	0.06	0.04	0.06
	1600	0.07	0.04	0.07
	1700	0.07	0.04	0.08
	1800	0.08	0.04	0.09
	1900	0.09	0.05	0.10
	2000	0.09	0.05	0.11
60 (5.0)	1100	0.02	0.02	0.04
	1200	0.03	0.02	0.04
	1300	0.04	0.02	0.05
	1400	0.05	0.03	0.05
	1500	0.06	0.04	0.06
	1600	0.07	0.04	0.07
	1700	0.07	0.04	0.08
	1800	0.08	0.04	0.09
	1900	0.09	0.05	0.10
	2000	0.09	0.05	0.11

1. The pressure drop through the economizer is greater for 100% outdoor air than for 100% return air. If the resistance of the return air duct is less than 0.25 IWG, the unit will deliver less CFM during full economizer operation. Filter pressure drop based on standard filter media tested at velocities not to exceed 300 ft/min.

BOTTOM DUCT DIMENSIONS (Inches)

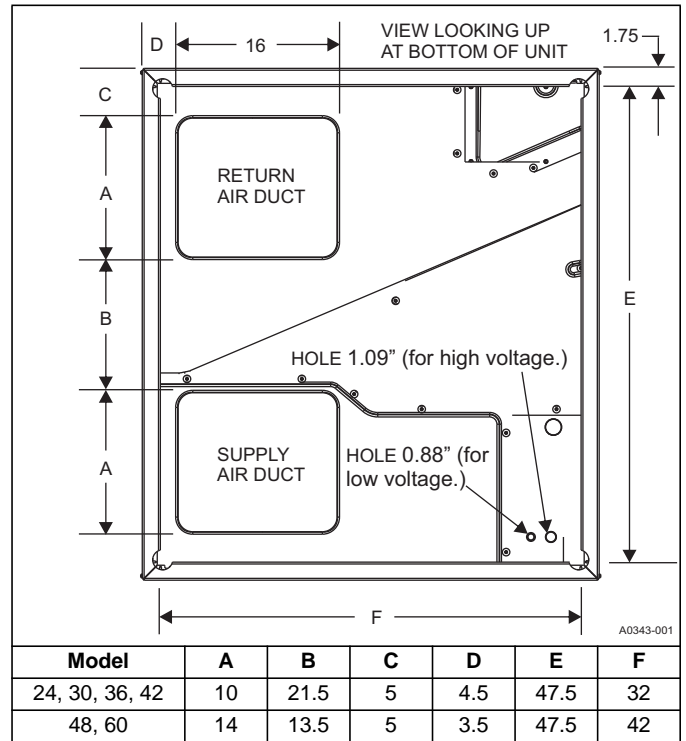

REAR DUCT DIMENSIONS (Inches)

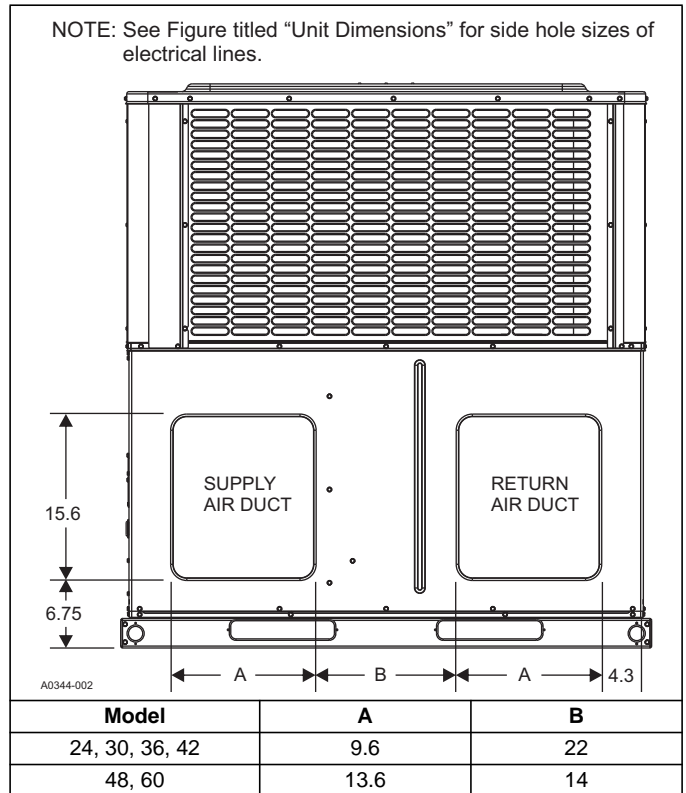

UNIT TYPICAL DUCT APPLICATIONS

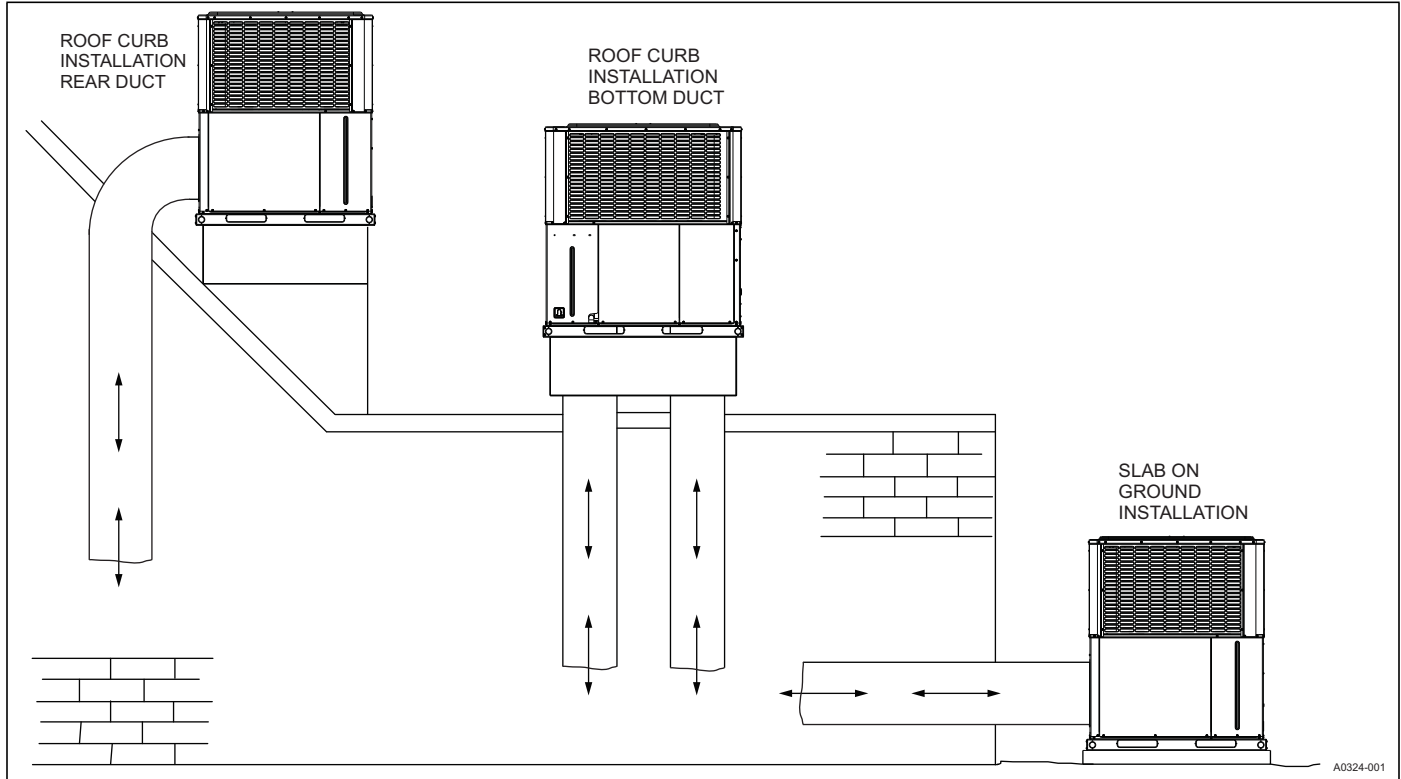

UNIT TYPICAL SLAB ON GROUND INSTALLATION

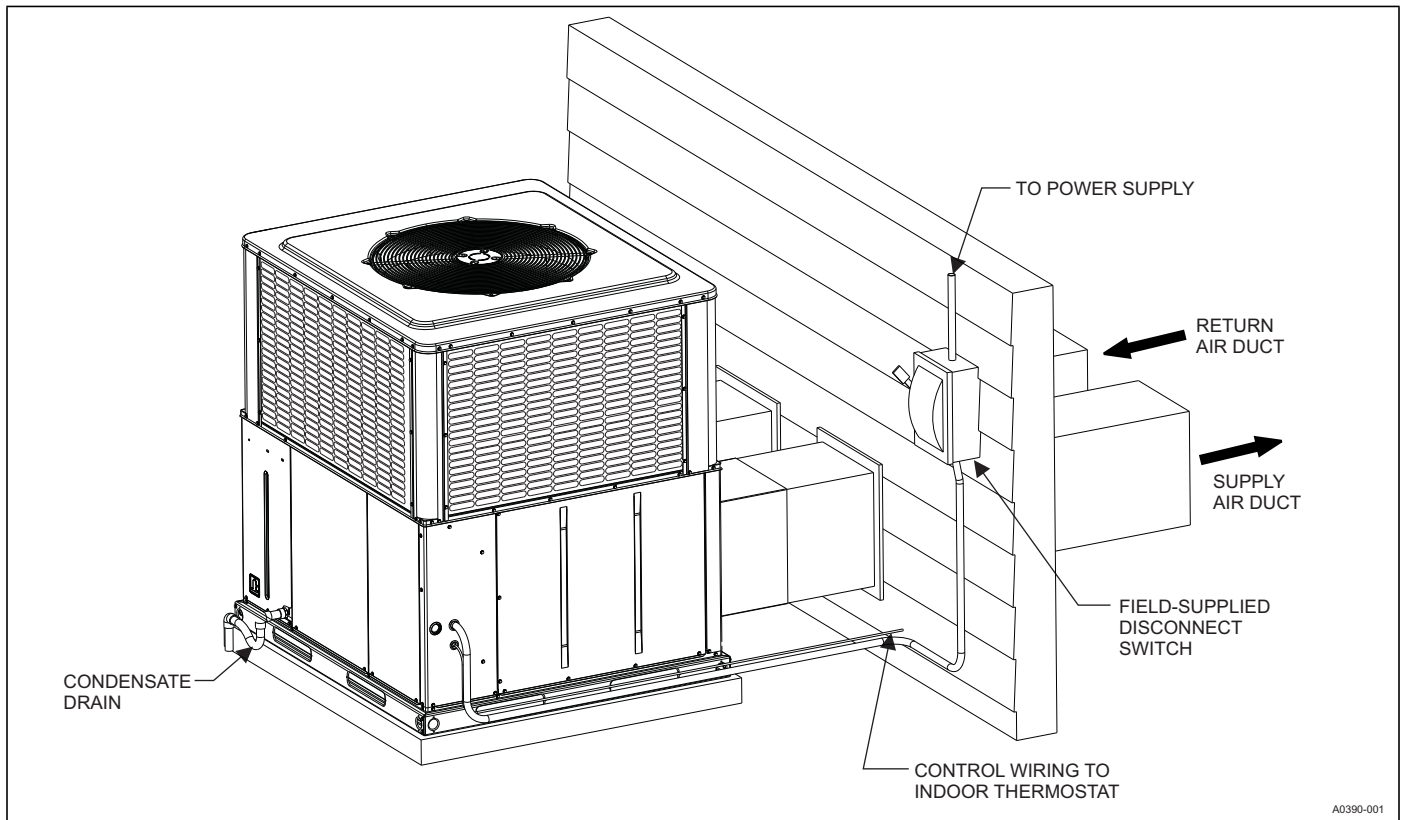

UNIT TYPICAL ROOF CURB INSTALLATION

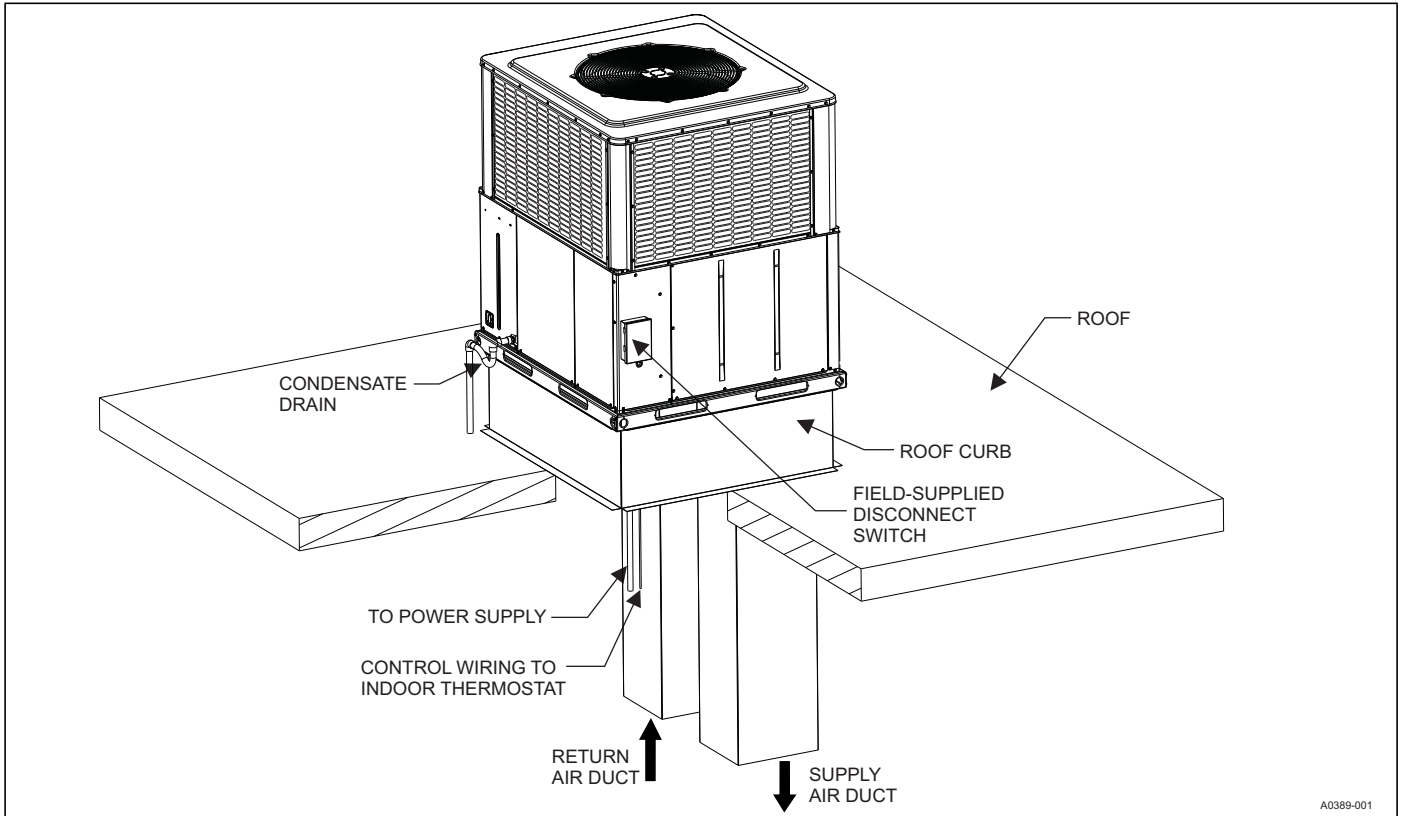

NOTES