



Air Conditioning & Heating

GMES80-U

HEATING INPUT : 40,000 – 80,000 BTU/H

*SINGLE-STAGE, MULTI-SPEED ECM,
MULTI-POSITION, ULTRA-LOW NOX
GAS FURNACE
80% AFUE*



Contents

Nomenclature.....	2
Product Specifications.....	3
Dimensions	4
Airflow Data	5
Wiring Diagrams	7
Accessories	8
Minimum Filter Sizes	8

Standard Features

- Heavy-duty stainless-steel dual-diameter tubular heat exchanger
- Single-stage gas valve
- Durable Hot-surface igniter
- Quiet, modulating draft inducer
- Self-diagnostic control board
- Multi-speed ECM blower motor
- California Ultra-Low NOx emissions compliant
- For installation in California’s South Coast Air Quality Management District (SCAQMD) only:
This furnace complies with the SCAQMD Rule 1111 14 ng/J NOx emission limit.
This furnace is eligible for the SCAQMD Clean Air Furnace Rebate Program: www.CleanAirFurnaceRebate.com.
- AHRI Certified; ETL Listed

Cabinet Features

- Installation: upflow, horizontal left or right
- Convenient left or right connection for gas and electrical service
- Heavy-gauge steel cabinet with durable baked-enamel finish
- Foil faced insulated heat exchanger



* Complete warranty details available from your local dealer or at www.goodmanmfg.com. To receive the Lifetime Heat Exchanger Limited Warranty (good for as long as you own your home) and 10-Year Parts Limited Warranty, online registration must be completed within 60 days of installation. Online registration is not required in California or Québec.

	G	M	E	S	80	040	4	C	*	**	
	1	2	3	4	5,6	7,8,9	10	11	12	13,14	
BRAND	G- Goodman® Brand										ENGINEERING
											Major /Minor Revisions * Not used for inventory control.
CONFIGURATION	M- Upflow/Horizontal C- Downflow/Horizontal										NOX
											N- Natural Gas X- Low NOx U- Ultra-Low NOx
MOTOR	V- Variable Speed ECM / ComfortBridge™ E- Multi-Speed ECM S- Single Speed										CABINET WIDTH
											A- 14" C- 21" B- 17½" D- 24½"
GAS VALVE	M- Modulating S- Single Stage C- Two Stage H- Convertible Single Phase										MAXIMUM CFM
											2- 800 CFM 4- 1600 CFM 3- 1200 CFM 5- 2000 CFM
AFUE	80- 80% AFUE										MBTU/h
											040- 40,000 BTU/h 100- 100,000 BTU/h 060- 60,000 BTU/h 080- 80,000 BTU/h

	GMES80 0403AU*	GMES80 0603AU*	GMES80 0604BU*	GMES80 0804BU*	GMES80 0805CU*
HEATING CAPACITY					
Input	40,000	60,000	60,000	80,000	80,000
Natural Gas Output	32,000	48,000	48,000	64,000	64,000
AFUE ¹	80	80	80	80	80
Available AC @ 0.5" ESP	3	3	4	4	5
Temperature Rise Range (°F)	25-55	20-50	20-50	35-65	35-65
CIRCULATOR BLOWER					
Size (D x W)	10" x 6"	10" x 6"	10" x 8"	10" x 8"	10" x 10"
Horsepower	0.5	0.5	0.75	0.75	1
Speed	5	5	5	5	5
Vent Diameter ²	4"	4"	4"	4"	4"
No. of Burners	2	3	3	4	4
ELECTRICAL DATA					
Min. Circuit Ampacity ³	8.7	8.7	12.45	12.45	15.5
Max. Overcurrent Device (amps) ⁴	15	15	15	15	20
SHIP WEIGHT (LBS)	86	90	100	108	116

¹ DOE AFUE based upon Isolated Combustion System (ICS)

² Vent and combustion air diameters may vary depending upon vent length. Refer to the latest editions of the National Fuel Gas Code NFPA 54/ANSI Z223.1 (in the USA) and the Canada National Standard of Canada, CAN/CSA B149.1 and CAN/CSA B142.2 (in Canada).

³ Minimum Circuit Ampacity = (1.25 x Circulator Blower Amps) + ID Blower amps. Wire size should be determined in accordance with National Electrical Codes. Extensive wire runs will require larger wire sizes.

⁴ Maximum Overcurrent Protection Device refers to maximum recommended fuse or circuit breaker size.
May use fuses or HACR-type circuit breakers of the same size as noted.

NOTES

- All furnaces are manufactured for use on 115 VAC, 60 Hz, single-phase electrical supply.
- Gas Service Connection ½" FPT
- Important: Size fuses and wires properly and make electrical connections in accordance with the National Electrical Code and/or all existing local codes.

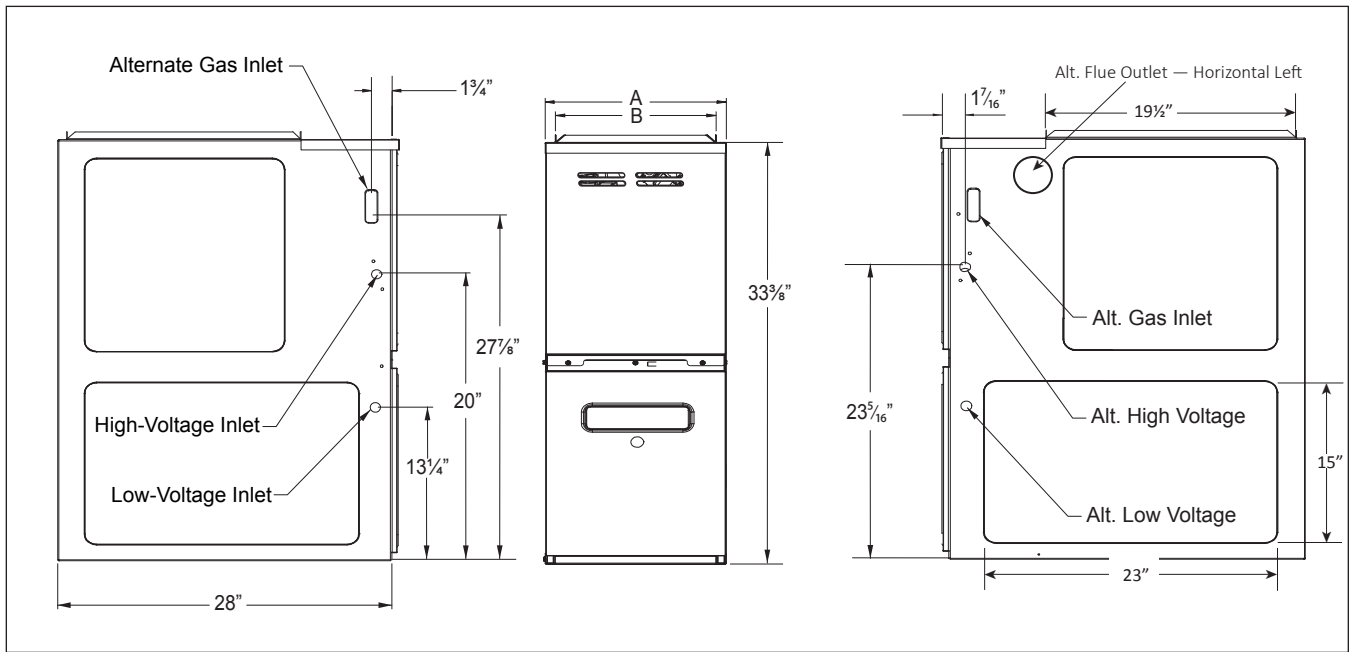

MODEL	A	B
GMES800403AU*	14"	12 1/2"
GMES800603AU*	14"	12 1/2"
GMES800604BU*	17 1/2"	16"
GMES800804BU*	17 1/2"	16"
GMES800805CU*	21"	19 1/2"

NOTES

- Line voltage wiring can enter through the right or left side of furnace.
- Low-voltage wiring can enter through the right or left side of furnace.

MINIMUM CLEARANCES TO COMBUSTIBLE MATERIALS

SIDES	REAR	FRONT ¹	VENT ²		TOP
			SW	B	
1"	0"	3"	6"	1"	1"

¹ 24" clearance for serviceability recommended.

² Single Wall Vent (SW) to be used only as a connector. Refer to the latest editions of the National Fuel Gas Code NFPA 54/ ANSI Z223.1 (in the USA) and the Canada National Standard of Canada, CAN/CSA B149.1 and CAN/CSA B142.2 (in Canada).

Note: GMES80 approved for line contact in the horizontal position.

MODEL	WIRE COLOR	EXTERNAL STATIC PRESSURE, (INCHES WATER COLUMN)												
		0.1		0.2		0.3		0.4		0.5		0.6	0.7	0.8
		CFM	RISE	CFM	RISE	CFM	RISE	CFM	RISE	CFM	RISE	CFM	CFM	CFM
GMES80 0403AU	Blue	789	38	735	40	676	44	625	47	588	50	545	500	437
	Red	1209	25	1141	26	1094	27	1048	28	1004	30	968	927	890
	Orange	696	43	556	53	494	NA	436	NA	377	NA	298	238	189
	Black	728	41	669	44	612	48	564	53	514	NA	464	417	337
	Brown	982	30	928	32	877	34	830	36	782	38	740	724	680
GMES80 0603AU	Blue	1309	34	1274	35	1242	36	1211	37	1180	38	1146	1117	1090
	Red	1120	40	1097	41	1059	42	1023	43	989	45	953	919	885
	Orange	708	NA	550	NA	501	NA	449	NA	389	NA	324	276	231
	Black	713	NA	665	NA	607	NA	558	NA	508	NA	462	412	351
	Brown	987	45	920	48	874	NA	852	NA	807	NA	770	733	692
GMES80 0604BU	Blue	1339	33	1279	35	1226	36	1175	38	1128	39	1081	1032	983
	Red	1828	24	1780	25	1738	26	1697	26	1663	27	1620	1588	1546
	Orange	898	49	794	NA	723	NA	656	NA	588	NA	522	449	384
	Black	1443	31	1388	32	1339	33	1292	34	1242	36	1202	1155	1107
	Brown*	1601	28	1559	29	1513	29	1473	30	1413	31	1405	1365	1325
GMES80 0804BU	Blue	1280	46	1249	47	1201	49	1159	51	1116	53	1073	1032	994
	Red	1743	NA	1703	35	1686	35	1669	36	1640	36	1608	1576	1543
	Orange	845	NA	664	NA	596	NA	525	NA	456	NA	381	318	257
	Black	1370	43	1352	44	1310	45	1269	47	1226	48	1186	1145	1107
	Brown*	1537	39	1498	40	1483	40	1450	41	1425	42	1389	1345	1313
GMES80 0805CU	Blue	1344	44	1273	47	1217	49	1148	52	1093	54	1029	972	910
	Red	2297	NA	2240	NA	2189	NA	2142	NA	2105	NA	2063	2027	1990
	Orange	1469	40	1415	42	1359	44	1305	45	1248	47	1194	1135	1083
	Black	1672	35	1605	37	1543	38	1488	40	1453	41	1403	1351	1301
	Brown	1899	NA	1840	NA	1784	NA	1731	NA	1687	35	1642	1597	1550

*Cooling Only

¹ at 0.5" ESP

Notes:

- CFM in chart is without filter(s). Filters do not ship with this furnace, but must be provided by the installer. If the furnace requires two return filters, this chart assumes both filters are installed.
- For most jobs, about 400 CFM per ton when cooling is desirable.
- INSTALLATION IS TO BE ADJUSTED TO OBTAIN TEMPERATURE RISE WITHIN THE RANGE SPECIFIED ON THE RATING PLATE.
- This chart is for information only. For satisfactory operation, external static pressure must not exceed value shown on the rating plate.
- NA indicates a temperature rise not recommended for this model.
- At higher altitudes, a properly derated unit will have approximately the same temperature rise at a particular CFM, while ESP at the CFM will be lower.

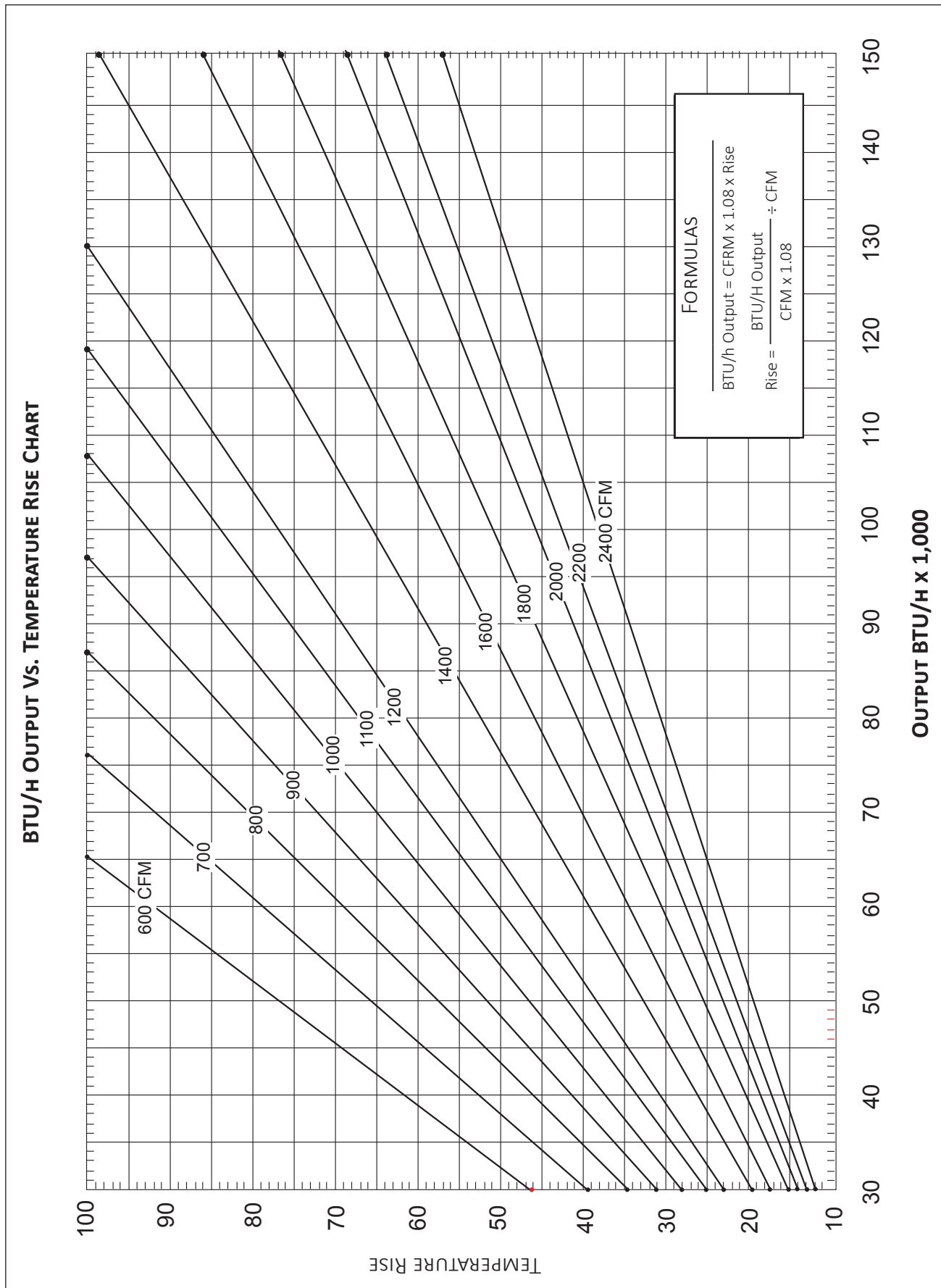

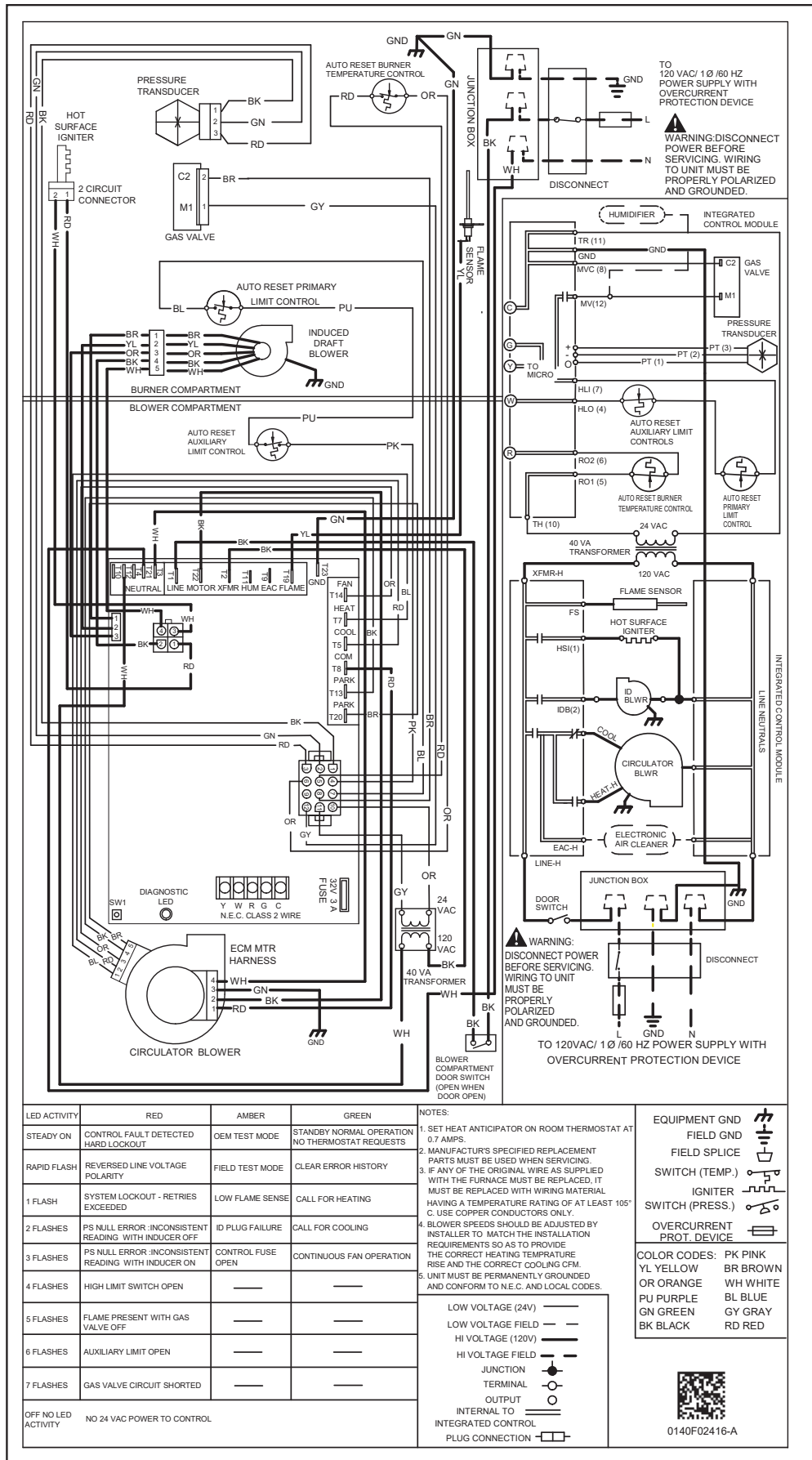

LED ACTIVITY	RED	AMBER	GREEN
STEADY ON	CONTROL FAULT DETECTED HARD LOCKOUT	OEM TEST MODE	STANDBY NORMAL OPERATION NO THERMOSTAT REQUESTS
RAPID FLASH	REVERSED LINE VOLTAGE POLARITY	FIELD TEST MODE	CLEAR ERROR HISTORY
1 FLASH	SYSTEM LOCKOUT - RETRIES EXCEEDED	LOW FLAME SENSE	CALL FOR HEATING
2 FLASHES	PS NULL ERROR- INCONSISTENT READING WITH INDUCER OFF	ID PLUG FAILURE	CALL FOR COOLING
3 FLASHES	PS NULL ERROR- INCONSISTENT READING WITH INDUCER ON	CONTROL FUSE OPEN	CONTINUOUS FAN OPERATION
4 FLASHES	HIGH LIMIT SWITCH OPEN	---	---
5 FLASHES	FLAME PRESENT WITH GAS VALVE OFF	---	---
6 FLASHES	AUXILIARY LIMIT OPEN	---	---
7 FLASHES	GAS VALVE CIRCUIT SHORTED	---	---
OFF NO LED ACTIVITY	NO 24 VAC POWER TO CONTROL		

- NOTES:
1. SET HEAT ANTICIPATOR ON ROOM THERMOSTAT AT 0.7 AMPS.
 2. MANUFACTURER'S SPECIFIED REPLACEMENT PARTS MUST BE USED WHEN SERVICING.
 3. IF ANY OF THE ORIGINAL WIRE AS SUPPLIED WITH THE FURNACE MUST BE REPLACED, IT MUST BE REPLACED WITH WIRING MATERIAL HAVING A TEMPERATURE RATING OF AT LEAST 105° C. USE COPPER CONDUCTORS ONLY.
 4. BLOWER SPEEDS SHOULD BE ADJUSTED BY INSTALLER TO MATCH THE INSTALLATION REQUIREMENTS SO AS TO PROVIDE THE CORRECT HEATING TEMPERATURE RISE AND THE CORRECT COOLING CFM.
 5. UNIT MUST BE PERMANENTLY GROUNDED AND CONFORM TO N.E.C. AND LOCAL CODES.
- LOW VOLTAGE (24V) ———
- LOW VOLTAGE FIELD ———
- HI VOLTAGE (120V) ———
- HI VOLTAGE FIELD ———
- JUNCTION ———
- TERMINAL ———
- OUTPUT ———
- INTERNAL TO INTEGRATED CONTROL ———
- PLUG CONNECTION ———

EQUIPMENT GND

FIELD GND

FIELD SPLICE

SWITCH (TEMP.)

IGNITER

SWITCH (PRESS.)

OVERCURRENT PROT. DEVICE

COLOR CODES: PK PINK
YL YELLOW BR BROWN
OR ORANGE WH WHITE
PU PURPLE BL BLUE
GN GREEN GY GRAY
BK BLACK RD RED

0140F02416-A

High Voltage: Disconnect all power before servicing or installing this unit. Multiple power sources may be present. Failure to do so may cause property damage, personal injury, or death.

WARNING

Wiring is subject to change. Always refer to the wiring diagram on the unit for the most up-to-date wiring.

MODEL	DESCRIPTION
AFE18-60A	Fossil Fuel Kit
MVK-01 ²	Masonry Vent Kit
TK-400	Twinning Kit

² Upflow applications only

MINIMUM FILTER SIZES

MODEL #	GMES80 0403AU*	GMES80 0603AU*	GMES80 0604BU*	GMES80 0804BU*	GMES80 0805CU*
Filter Size (in ²)	(1) 16 x 25 (Side) or (1) 14 x 24 (Bottom)		(1) 16 x 25 (Side or Bottom)		(2) 16 x 25 (Side) or (1) 20 x 25 (Bottom) ¹

Note: Larger filters may be used; filters may also be centrally located.

¹ Use 2- 16 x 25 filters on side returns or 20 x 25 filter on bottom return if furnace is connected to a cooling unit over 4 tons nominal capacity.