

6 TON PACKAGED HEAT PUMPS

UP TO 15.5 IEER

8.0 HSPF

COOLING CAPACITY: UP TO 71,000 BTU/H

HEATING CAPACITY: UP TO 70,000 BTU/H



■ Contents

Nomenclature.....	2
Product Specifications.....	4
Expanded Cooling Data	5
Airflow Data	7
Expanded Heating Data	8
Crankcase Heater.....	9
Electrical Data / Heat Kit Data	10
Dimensions	12
Wiring Diagrams	16
– for Models with DDC Controls	19
Accessories	24

■ Standard Features

- High-efficiency scroll compressor
- Copper tube / aluminum fin coils
- High- and low-pressure switches
- Refrigerant accumulator
- Contactor with lugs
- High-capacity, steel-cased filter drier
- Heater kits with single-point entry
- 24-volt terminal strip
- Convertible airflow orientation
- Easy to service
- Built-in filter rack with standard 2" filters
- Bottom utility entry
- AHRI Certified; ETL Listed
- 6-ton with two-speed blower motor and two-stage compressor meet the performance specified as of 1/1/2016 in Table 6.8.1-2 of ASHRAE STANDARD 90.1-2013

■ Cabinet Features

- Heavy-gauge, galvanized-steel cabinet with UV-resistant powder-paint finish
- Full Perimeter Rail
- Sloped drain pan



* Complete warranty details available from your local distributor or manufacturer's representative or at www.daikincomfort.com.

		D	C	H	060	090	3	V	*	*	*	A	*		
		1	2	3	4,5,6	7,8,9	10	11	12	13	14	15	16		
													REVISION LEVELS		
													Major & Minor		
													FACTORY-INSTALLED OPTIONS		
BRAND													FACTORY-INSTALLED OPTIONS		
D Daikin													X No Options		
CONFIGURATION													A Non-powered convenience outlet		
C Standard Efficiency (6 - 25 Tons)													B Powered convenience outlet		
S Standard Efficiency (3 - 5 Tons)													C Low-ambient kit		
T High Efficiency (3 - 5 Tons)													D Return air smoke detector		
APPLICATION													E Supply air smoke detector		
C Cooling ¹													F Non-powered convenience outlet; Low-ambient kit		
G Gas Heat													G Non-powered convenience outlet; Return air smoke detector		
H Heat Pump ¹													H Non-powered convenience outlet; Supply air smoke detector		
NOMINAL COOLING CAPACITY													J Non-powered convenience outlet; Return & Supply air smoke detectors		
036	3 Tons	102	8½ Tons	300	25 Tons									K Non-powered convenience outlet; Low-ambient kit; Supply air smoke detector	
048	4 Tons	120	10 Tons									L Non-powered convenience outlet; Low-ambient kit			
060	5 Tons	150	12½ tons									M Powered convenience outlet; Low-ambient kit			
072	6 Tons	180	15 Tons									N Powered convenience outlet; Return air smoke detector			
090	7½ Tons	240	20 Tons									O Powered convenience outlet; Return & Supply air smoke detectors			
NOMINAL HEATING CAPACITY													P Powered convenience outlet; Supply air smoke detector		
Gas/Electric		A/C H/P		Factory-Installed Electric Heat										Q Powered convenience outlet; Low-ambient kit; Return air smoke detector	
045	45,000 BTU/h	XXX	No Heat									R Powered convenience outlet; Low-ambient kit; Supply air smoke detector			
090	90,000 BTU/h	010	10 kW	030	30 kW									T Powered convenience outlet; Low-ambient kit; Return & Supply air smoke detectors	
115	115,000 BTU/h	015	15 kW	031	30 kW									U Non-powered convenience outlet; Low-ambient kit; Return air smoke detector	
140	140,000 BTU/h	016	15 kW	045	45 kW									V Low-ambient kit; Return air smoke detector	
210	210,000 BTU/h	018	18 kW	046	45 kW									W Low-ambient kit; Supply air smoke detector	
350	350,000 BTU/h	020	20 kW	060	60 kW									Y Low-ambient kit; Return & Supply air smoke detectors	
400	400,000 BTU/h	025	25 kW									Z Return & Supply air smoke detectors			
See product specifications for heat size(s) available for each capacity.															
VOLTAGE													FACTORY-INSTALLED OPTIONS		
1	208-230/1/60 (DS* & DT* 3-5 Tons models only)	4		460/3/60										X Standard Alumined Heat Exchanger	
3	208-230/3/60	7		575/3/60										S Stainless-Steel Heat Exchanger	
SUPPLY FAN/DRIVE TYPE/MOTOR													D Hinged Panels		
B Belt Drive (3-5 Tons single speed models only)		V		Two-Speed Belt Drive (6-25 Tons only)										K Stainless-Steel Heat Exchanger; Hinged Panels	
D Direct Drive (3-5 Tons single speed models only)		W		High Static (6-25 Tons two-speed Belt Drive models only)										B Phase Monitor	
H High Static (3-5 Tons single-speed Belt Drive models only)		X		No Options										J Stainless Steel Heat Exchanger; Phase Monitor	
FACTORY-INSTALLED OPTIONS													M Hinged Panel; Phase Monitor		
A Ultra Low-Leak Downflow Economizer		R		Ultra Low-Leak Downflow Economizer; DDC-BACnet protocol;										L Stainless-Steel Heat Exchanger; Hinged Panels; Phase Monitor	
B DDC-BACnet protocol		V		Low-Leak Downflow Economizer											
F Ultra Low-Leak Downflow Economizer; DDC-BACnet protocol		W		Low-Leak Downflow Economizer Disconnect Switch (non-fused)											
H Disconnect Switch (non-fused)		X		No Options											
J Ultra Low-Leak Downflow Economizer; Disconnect Switch (non-fused)															
M Disconnect Switch (non-fused); DDC-BACnet protocol															
Note: Not all options available for all products.															
¹ X= No Options in character 13th															

FACTORY-INSTALLED OPTIONS

- Stainless-Steel Heat Exchanger (Gas only units): A tubular heat exchanger made of 409-type stainless steel is installed in the unit.
- Low-Ambient Kit: Allows for cooling operation at lower outdoor temperatures. On the 3- to 6-ton units, cooling operation is extended from 60°F ambient temperature to 35°F outside air temperature. On 7½ -20 ton units, cooling operation is extended from 35°F ambient temperature to 0°F outside air temperature. For 25 ton units, cooling operation is extended from 24°F ambient temperature to 0°F outside air temperature.
- Economizers (Downflow): Based on air conditions, can provide outside air to cool the space.
- Electric Heat Kits (A/C and Heat Pump units only): Available in all voltage options.
- Non-powered Convenience Outlet: A 120V, 15A, GFCI outlet makes it easier for technicians to service the unit once an electrician runs power to the outlet.
- Powered Convenience Outlet: A 120V, 15A, GFCI outlet powered with a transformer built into the unit. When a factory-installed powered convenience outlet is installed in the equipment, the unit MCA (Min. Circuit Ampacity) will increase by 7.2A/6.5A for 208/230V units, increase by 3.3A for 460V units, and by 2.6A for 575V units. The MOP (Max. Overcurrent Protection) device must be sized accordingly.
- Disconnect Switch (non-fused; 3-phase units only): A disconnect switch is installed in the unit and factory wiring will be complete from the switch to the unit. Please note that for air conditioning and heat pump models, the appropriate electric heat kit must be ordered to be factory-installed along with the disconnect switch (non-fused) when it is ordered. Please note that for models with a powered convenience outlet option and a disconnect switch (non-fused) option, the power to the powered convenience outlet will be shut off when the disconnect switch (non-fused) is in the off position.
- Return Air and/or Supply Air Smoke Detectors: Return air and/or supply air smoke detectors are installed in the unit.
- Hinged Access Panels: Allows access to unit's major components. Combined with latches for easy access to control box, compressor, filters and blower motor. Available on all units.
- Two-speed indoor fan blower models are standard on 6, 7½, 8½, 10, 12½, 15, 20 & 25 ton units. Section 6.4.3.10.b of ASHRAE Standard 90.1-2010 and Section 6.5.3.2.1.a of ASHRAE Standard 90.1-2013 require a minimum of two fan speeds. Section 140.4(m)1 of California Energy Commission Title 24 2013 contains a similar provision. When the units with the two-speed indoor fan blowers operate on a call for the first stage of cooling, the fan operates at low speed, which is 66% of full speed. When the units operate on a call for the second stage of cooling, the fan operates at full speed. In heating operation, the fan operates at full speed. During ventilation operation, the fan operates at low speed.
- Phase Monitor: Phase monitor (3 phase only), available for 3 - 25 ton DS, DC and DT series models. Phase monitor shall provide protection for motors and compressors against problems caused by phase loss, phase reversal and phase unbalance. Phase monitor is equipped with an LED that provides an ON or FAULT indicator.
- DDC Controller: DDC communicating controller, available for 3 - 25 ton DS, DC and DT series models with on-board BACnet® communication interface.
- High static blower assembly, factory-installed.

	DCH072 ***3V***A*	DCH072 ***4V***A*	DCH072 ***7V***A*
COOLING CAPACITY			
Total BTU/h	69,000	69,000	69,000
Sensible BTU/h	50,000	50,000	50,000
EER / IEER	11.2/15.0	11.2/15.0	11.2/15.0
Decibels	78.0	78.0	78.0
AHRI Number	8952850	8952850	8952850
HEATING CAPACITY			
BTU/h (47° F)	69,000	69,000	69,000
COP (47°F)	3.7	3.7	3.7
BTU/h (17° F)	38,000	38,000	38,000
COP (17°F)	2.3	2.3	2.3
EVAPORATOR MOTOR / COIL			
Motor Type	2-speed Belt Drive	2-speed Belt Drive	2-speed Belt Drive
# of Wheels (D x W)	1 (11" x 10")	1 (11" x 10")	1 (11" x 10")
Indoor Nominal CFM	2,350	2,350	2,350
Motor Speed Tap (Cooling)	---	---	---
Indoor Motor FLA (Cooling)	6.0	2.9	2.4
Horsepower - RPM	2.0-1,725	2.0-1,725	2.0-1,725
Piston Size (Cooling)	TXV	TXV	TXV
Filter Size (Qty)	(4) 16" x 20" x 2"	(4) 16" x 20" x 2"	(4) 16" x 20" x 2"
Drain Size (NPT)	¾"	¾"	¾"
R-410A Refrigerant Charge (oz.)	241.0	241.0	241.0
Evaporator Coil Face Area (ft ²)	8.9	8.9	8.9
Rows Deep/ Fins per Inch	4/16	4/16	4/16
Motor Sheave	VL44 X 7/8	VL44 x 7/8	VL44 x 7/8
Blower Sheave / Belt	AK59x1 / AX53	AK59x1 / AX53	AK59x1 / AX53
CONDENSER FAN / COIL			
Quantity of Condenser Fan Motors	1	1	1
Horsepower - RPM	½ - 1,075	½ - 1,075	½ - 1,075
Fan Diameter/ # Fan Blades	22/ 4	22/ 4	22/ 4
Outdoor Nominal CFM	4,300	4,300	4,300
Face Area (ft ²)	18.7	18.7	18.7
Rows Deep/ Fins per Inch	2/ 20	2/ 20	2/ 20
Piston Size (Heating)	0.080	0.080	0.080
COMPRESSOR			
Quantity / Stage	1 /Two	1 /Two	1 /Two
Type	Scroll	Scroll	Scroll
Compressor RLA / LRA	17.6/136	8.5/66.1	6.3/55.3
ELECTRICAL DATA			
Voltage/ Phase/ Frequency	208/230-3-60	460-3-60	575-3-60
Outdoor Fan FLA	2.0	0.85	0.67
Total Unit Amps	25.60	12.3	9.4
Min. Circuit Ampacity ¹	30 / 30	14.3	11
Max. Overcurrent Protection (amps) ²	45 / 45	20	15
Entrance Power Supply	1.125"	1.125"	1.125"
Entrance Control Voltage	½"	½"	½"
OPERATING WEIGHT (LBS)			
	650	650	650
SHIP WEIGHT (LBS)			
	675	675	675

¹ Wire size should be determined in accordance with National Electrical Codes. Extensive wire runs will require larger wire sizes.

² May use fuses or HACR-type circuit breakers of the same size as noted.

NOTES

- Always check the S&R plate for electrical data on the unit being installed.
- When a factory-installed powered convenience outlet is installed in the equipment, the unit MCA (Min. Circuit Ampacity) will increase by 7.2A/6.5A for 208/230V units, increase by 3.3A for 460V units, and by 2.6A for 575V units. The MOP (Max. Overcurrent Protection) device must be sized accordingly.

IDB		OUTDOOR AMBIENT TEMPERATURE												ENTERING INDOOR WET BULB TEMPERATURE												
		65				75				85				95				105				115				
		59	63	67	71	59	63	67	71	59	63	67	71	59	63	67	71	59	63	67	71	59	63	67	71	
70	MBh	67.6	70.1	76.8	-	66.0	68.5	75.0	-	64.5	66.8	73.2	-	62.9	65.2	71.4	-	59.8	61.9	67.9	-	55.3	57.4	62.9	-	
	S/T	0.72	0.60	0.42	-	0.75	0.63	0.43	-	0.77	0.64	0.44	-	0.79	0.66	0.46	-	0.82	0.69	0.48	-	0.83	0.69	0.48	-	
	Delta T	18	15	12	-	18	16	12	-	18	16	12	-	18	16	12	-	18	16	12	-	17	14	11	-	
	KW	4.89	4.98	5.13	-	5.23	5.34	5.50	-	5.54	5.65	5.82	-	5.81	5.93	6.11	-	6.04	6.16	6.36	-	6.24	6.37	6.57	-	
	HI PR	231	248	262	-	259	279	294	-	294	317	335	-	335	361	381	-	377	406	429	-	417	449	474	-	
	LO PR	110	117	128	-	116	124	135	-	121	129	140	-	127	135	147	-	133	142	155	-	138	146	160	-	
	MBh	65.6	68.0	74.5	-	64.1	66.5	72.8	-	62.6	64.9	71.1	-	61.1	63.3	69.3	-	58.0	60.1	65.9	-	53.7	55.7	61.0	-	
	S/T	0.69	0.58	0.40	-	0.71	0.60	0.41	-	0.73	0.61	0.42	-	0.76	0.63	0.44	-	0.79	0.66	0.45	-	0.79	0.66	0.46	-	
	Delta T	19	16	12	-	19	16	12	-	19	16	12	-	19	16	12	-	19	16	12	-	17	15	11	-	
	KW	4.85	4.95	5.09	-	5.19	5.30	5.46	-	5.50	5.61	5.78	-	5.76	5.88	6.06	-	5.99	6.12	6.31	-	6.19	6.32	6.51	-	
HI PR	228	246	260	-	256	276	291	-	292	314	331	-	332	357	377	-	374	402	424	-	413	444	469	-		
LO PR	109	116	127	-	115	123	134	-	120	127	139	-	126	134	146	-	132	140	153	-	136	145	158	-		
1991	MBh	62.4	64.6	70.8	-	60.9	63.1	69.2	-	59.5	61.6	67.5	-	58.0	60.1	65.9	-	55.1	57.1	62.6	-	51.1	52.9	58.0	-	
	S/T	0.66	0.55	0.38	-	0.68	0.57	0.40	-	0.70	0.59	0.41	-	0.72	0.61	0.42	-	0.75	0.63	0.44	-	0.76	0.63	0.44	-	
	Delta T	19	16	12	-	19	17	13	-	19	17	13	-	19	17	13	-	19	17	13	-	18	15	12	-	
	KW	4.78	4.87	5.01	-	5.12	5.22	5.37	-	5.41	5.52	5.69	-	5.67	5.79	5.97	-	5.90	6.02	6.21	-	6.09	6.22	6.41	-	
	HI PR	224	241	254	-	251	270	285	-	286	307	325	-	325	350	370	-	366	394	416	-	404	435	460	-	
	LO PR	107	114	124	-	113	120	131	-	117	125	136	-	123	131	143	-	129	137	150	-	134	142	155	-	
	75	MBh	68.8	70.8	76.6	82.2	67.2	69.1	74.8	80.3	65.6	67.5	73.1	78.4	64.0	65.9	71.3	76.5	60.8	62.6	67.7	72.7	56.3	58.0	62.7	67.3
		S/T	0.82	0.74	0.56	0.36	0.85	0.76	0.58	0.37	0.87	0.78	0.59	0.38	0.90	0.81	0.61	0.39	0.94	0.84	0.63	0.41	0.94	0.84	0.64	0.41
		Delta T	21	19	16	11	21	19	16	11	21	19	16	11	21	19	16	11	21	19	16	11	19	18	15	10
		KW	4.92	5.02	5.17	5.32	5.27	5.38	5.54	5.71	5.58	5.70	5.87	6.05	5.85	5.98	6.16	6.35	6.09	6.21	6.41	6.61	6.29	6.42	6.62	6.83
HI PR		233	251	265	276	262	281	297	310	297	320	338	353	339	365	385	402	381	410	433	452	421	453	479	499	
LO PR		111	118	129	138	118	125	136	145	122	130	142	151	128	136	149	159	134	143	156	166	139	148	161	172	
MBh		66.8	68.7	74.4	79.8	65.2	67.1	72.7	78.0	63.7	65.5	70.9	76.1	62.1	63.9	69.2	74.3	59.0	60.7	65.7	70.6	54.6	56.3	60.9	65.4	
S/T		0.78	0.70	0.53	0.34	0.81	0.73	0.55	0.35	0.83	0.75	0.56	0.36	0.86	0.77	0.58	0.37	0.89	0.80	0.60	0.39	0.90	0.81	0.61	0.39	
Delta T		21	20	16	11	22	20	16	11	22	20	16	11	22	20	16	11	22	20	16	11	20	19	15	10	
KW		4.89	4.98	5.13	5.28	5.23	5.34	5.50	5.66	5.54	5.65	5.82	6.00	5.81	5.93	6.11	6.30	6.04	6.16	6.36	6.56	6.24	6.37	6.57	6.78	
HI PR	231	248	262	274	259	279	294	307	294	317	335	349	335	361	381	398	377	406	429	447	417	449	474	494		
LO PR	110	117	128	136	116	124	135	144	121	129	140	150	127	135	148	157	133	142	155	165	138	146	160	170		
1991	MBh	63.4	65.3	70.7	75.9	61.9	63.8	69.0	74.1	60.5	62.3	67.4	72.3	59.0	60.7	65.7	70.6	56.0	57.7	62.5	67.0	51.9	53.5	57.9	62.1	
	S/T	0.75	0.67	0.51	0.33	0.78	0.70	0.53	0.34	0.80	0.71	0.54	0.35	0.82	0.74	0.56	0.36	0.86	0.76	0.58	0.37	0.86	0.77	0.58	0.38	
	Delta T	22	20	17	11	22	20	17	12	22	21	17	12	22	21	17	12	22	20	17	12	21	19	16	11	
	KW	4.82	4.91	5.05	5.20	5.16	5.26	5.41	5.58	5.46	5.57	5.73	5.91	5.72	5.84	6.02	6.20	5.94	6.07	6.26	6.45	6.14	6.27	6.46	6.67	
	HI PR	226	243	257	268	254	273	288	301	289	311	328	342	329	354	374	390	370	398	420	438	409	440	464	484	
	LO PR	108	115	125	133	114	121	132	141	118	126	138	147	124	132	145	154	130	139	151	161	135	144	157	167	

IDB = Entering Indoor Dry Bulb Temperature
 High & low pressures are measured at the liquid & suction service ports.
 Shaded area reflects ACCA (TVA) conditions
 Amps: Unit amps (comp.+ evaporator + condenser fan motors)
 kW = Total system power

EXPANDED COOLING DATA — 6 TONS (2 SPEED) (CONT.)

IDB	AIRFLOW	OUTDOOR AMBIENT TEMPERATURE																																	
		65					75					85					95					105					115								
		59	63	67	71	75	59	63	67	71	75	59	63	67	71	75	59	63	67	71	75	59	63	67	71	75	59	63	67	71	75				
80	MBh	70.0	71.5	76.4	81.7	68.4	69.8	74.6	79.8	77.9	66.7	68.2	72.8	77.9	75.6	65.1	66.5	71.1	76.0	73.8	63.2	64.6	69.0	73.8	71.6	60.0	61.4	65.6	70.1	67.9	55.6	56.8	60.7	64.9	62.7
	S/T	0.90	0.85	0.69	0.51	0.93	0.88	0.71	0.53	0.55	0.96	0.90	0.73	0.55	0.52	1.00	0.93	0.75	0.56	0.54	0.94	0.88	0.72	0.54	0.52	0.98	0.92	0.75	0.56	0.56	0.99	0.93	0.75	0.56	0.56
	Delta T	23	22	19	15	23	22	19	15	16	23	22	19	16	16	24	22	20	16	16	24	23	20	16	16	24	23	20	16	16	22	22	19	15	15
	KW	4.96	5.06	5.21	5.36	5.31	5.42	5.58	5.75	6.10	5.63	5.74	5.91	6.10	6.05	5.90	6.02	6.21	6.40	6.35	5.85	5.98	6.16	6.35	6.29	5.69	5.82	6.01	6.21	6.16	5.42	5.55	5.74	5.94	5.83
	HI PR	235	253	268	279	264	284	300	313	356	300	323	341	356	353	342	368	389	406	406	385	414	437	456	452	381	410	433	452	451	421	453	479	499	489
	LO PR	112	120	130	139	119	126	138	147	153	123	131	143	153	151	123	131	143	153	151	128	136	149	159	166	134	143	156	166	166	139	148	162	172	172
	MBh	64.5	66.0	70.5	75.3	63.0	64.4	68.8	73.6	71.8	61.5	62.9	67.2	71.8	70.1	60.0	61.4	65.6	70.1	67.9	57.0	58.3	62.3	66.6	64.4	52.8	54.0	57.7	61.7	61.7	52.8	54.0	57.7	61.7	61.7
S/T	0.82	0.77	0.63	0.47	0.85	0.80	0.65	0.49	0.50	0.88	0.82	0.67	0.50	0.52	0.90	0.85	0.69	0.52	0.52	0.94	0.88	0.72	0.54	0.54	0.95	0.89	0.72	0.54	0.54	0.95	0.89	0.72	0.54	0.54	
Delta T	25	24	20	16	25	24	21	17	17	25	24	21	17	17	25	24	21	17	17	25	24	21	17	17	25	24	21	17	17	23	22	19	15	15	
KW	4.85	4.95	5.09	5.24	5.19	5.30	5.46	5.62	5.96	5.50	5.61	5.78	5.96	5.96	5.76	5.88	6.06	6.25	6.25	5.59	5.71	5.90	6.09	6.09	5.32	5.44	5.63	5.82	5.82	5.05	5.17	5.36	5.55	5.55	
HI PR	228	246	260	271	256	276	291	304	346	292	314	331	346	346	332	357	377	394	394	374	402	424	443	443	413	444	469	489	489	413	444	469	489	489	
LO PR	109	116	127	135	115	123	134	142	148	120	127	139	148	148	126	134	146	156	156	132	140	153	163	163	136	145	158	168	168	136	145	158	168	168	

IDB	AIRFLOW	OUTDOOR AMBIENT TEMPERATURE																																	
		65					75					85					95					105					115								
		59	63	67	71	75	59	63	67	71	75	59	63	67	71	75	59	63	67	71	75	59	63	67	71	75	59	63	67	71	75				
85	MBh	71.2	72.6	76.0	81.1	69.5	70.9	74.3	79.2	77.3	67.9	69.2	72.5	77.3	75.1	66.2	67.5	70.7	75.4	73.2	64.3	65.6	68.7	73.2	71.0	61.1	62.3	65.2	69.6	67.4	58.3	59.4	62.2	66.4	64.2
	S/T	0.95	0.91	0.82	0.67	0.98	0.95	0.85	0.69	0.71	1.00	0.97	0.87	0.71	0.68	1.00	1.00	0.90	0.73	0.70	0.99	0.95	0.86	0.70	0.70	1.00	0.99	0.89	0.73	0.73	1.00	1.00	0.94	0.76	0.76
	Delta T	25	24	23	20	25	24	23	20	20	25	24	23	20	20	24	25	23	20	20	23	23	23	20	20	23	23	23	20	20	21	22	21	19	19
	KW	5.00	5.09	5.24	5.40	5.35	5.46	5.62	5.80	6.15	5.67	5.78	5.96	6.15	6.15	5.95	6.07	6.26	6.46	6.46	5.68	5.81	6.00	6.20	6.20	5.39	5.52	5.71	5.90	5.90	5.12	5.25	5.44	5.63	5.63
	HI PR	238	256	270	282	267	287	303	316	360	303	327	345	360	360	346	372	393	410	410	389	418	442	461	461	430	462	488	509	509	430	462	488	509	509
	LO PR	113	121	132	140	120	128	139	148	154	125	133	145	154	154	131	139	152	162	162	137	146	159	170	170	142	151	165	175	175	142	151	165	175	175
	MBh	69.1	70.5	73.8	78.7	67.5	68.8	72.1	76.9	75.1	65.9	67.2	70.4	75.1	73.2	64.3	65.6	68.7	73.2	71.0	61.1	62.3	65.2	69.6	67.4	58.3	59.4	62.2	66.4	64.2	55.5	56.6	59.4	63.6	61.4
S/T	0.90	0.87	0.79	0.64	0.93	0.90	0.81	0.66	0.66	0.96	0.92	0.83	0.68	0.68	0.99	0.95	0.86	0.70	0.70	1.00	0.99	0.89	0.73	0.73	1.00	1.00	0.94	0.76	0.76	1.00	1.00	0.94	0.76	0.76	
Delta T	25	25	24	20	26	25	24	21	21	26	25	24	21	21	26	26	24	21	21	25	25	24	21	21	23	24	24	21	21	23	24	24	21	21	
KW	4.96	5.06	5.21	5.36	5.31	5.42	5.58	5.75	6.10	5.63	5.74	5.91	6.10	6.10	5.90	6.02	6.21	6.40	6.40	5.68	5.81	6.00	6.20	6.20	5.42	5.55	5.74	5.93	5.93	5.15	5.28	5.47	5.66	5.66	
HI PR	235	253	268	279	264	284	300	313	356	300	323	341	356	356	342	368	389	406	406	385	414	437	456	456	425	458	483	504	504	425	458	483	504	504	
LO PR	112	120	130	139	119	126	138	147	153	123	131	143	153	153	130	138	150	160	160	136	144	158	168	168	140	149	163	174	174	140	149	163	174	174	

IDB = Entering Indoor Dry Bulb Temperature
 High & low pressures are measured at the liquid & suction service ports.
 Shaded area reflects AHRI conditions
 Amps: Unit: amps (comp.+ evaporator + condenser fan motors)
 kW = Total system power

DCH072 TWO-SPEED STANDARD BELT DRIVE AT HIGH SPEED - HORIZONTAL

ESP ("W.C.)	0 TURNS		1 TURN		2 TURNS		3 TURNS		4 TURNS		5 TURNS	
	CFM	BHP	CFM	BHP	CFM	BHP	CFM	BHP	CFM	BHP	CFM	BHP
0.2	---	---	---	---	---	---	2784	1.30	2582	0.83	2411	0.79
0.4	---	---	---	---	2814	1.34	2620	1.19	2342	0.72	2105	0.66
0.6	---	---	2665	1.34	2583	1.19	2398	1.06	2103	0.62	1902	0.57
0.8	2689	1.38	2492	1.22	2370	1.07	2142	0.91	1816	0.51	---	---
1.0	2438	1.22	2275	1.09	2098	0.92	1883	0.78	---	---	---	---
1.2	2250	1.10	1996	0.92	---	---	---	---	---	---	---	---

DCH072 TWO-SPEED STANDARD BELT DRIVE AT HIGH SPEED - DOWN SHOT

ESP ("W.C.)	0 TURNS		1 TURN		2 TURNS		3 TURNS		4 TURNS		5 TURNS	
	CFM	BHP	CFM	BHP	CFM	BHP	CFM	BHP	CFM	BHP	CFM	BHP
0.2	---	---	---	---	2771	1.27	2567	1.05	2421	0.88	2220	0.71
0.4	---	---	2753	1.38	2573	1.15	2382	0.95	2186	0.77	1980	0.61
0.6	2655	1.42	2548	1.24	2360	1.02	2119	0.81	1934	0.65	---	---
0.8	2470	1.30	2331	1.11	2111	0.89	1868	0.69	---	---	---	---
1.0	2296	1.18	2078	0.96	1840	0.75	---	---	---	---	---	---
1.2	2040	1.02	---	---	---	---	---	---	---	---	---	---

DCH072 HIGH STATIC BELT DRIVE AT HIGH SPEED — HORIZONTAL

ESP ("W.C.)	0 TURNS		1 TURN		2 TURNS		3 TURNS		4 TURNS		5 TURNS	
	CFM	BHP	CFM	BHP	CFM	BHP	CFM	BHP	CFM	BHP	CFM	BHP
0.6	---	---	---	---	---	---	---	---	2746	1.38	2515	1.12
0.8	---	---	---	---	---	---	2721	1.47	2494	1.21	2261	0.97
1.0	---	---	---	---	2689	1.56	2500	1.32	2255	1.06	1994	0.83
1.2	---	---	2752	1.74	2473	1.40	2252	1.15	1996	0.91	---	---
1.4	2802	1.88	2487	1.53	2286	1.27	2037	1.02	---	---	---	---
1.6	2553	1.67	2308	1.40	1997	1.08	---	---	---	---	---	---
1.8	2355	1.51	2014	1.19	---	---	---	---	---	---	---	---
2.0	2055	1.29	---	---	---	---	---	---	---	---	---	---

DCH072 HIGH STATIC BELT DRIVE AT HIGH SPEED — DOWN SHOT

ESP ("W.C.)	0 TURNS		1 TURN		2 TURNS		3 TURNS		4 TURNS		5 TURNS	
	CFM	BHP	CFM	BHP	CFM	BHP	CFM	BHP	CFM	BHP	CFM	BHP
0.6	---	---	---	---	2793	1.64	2603	1.39	2450	1.18	2270	0.97
0.8	---	---	2903	1.87	2696	1.57	2369	1.23	2236	1.05	1987	0.82
1.0	2776	1.86	2682.5	1.69	2445	1.38	2196	1.12	1968	0.90	---	---
1.2	2599	1.71	2539	1.57	2310	1.29	1932	0.96	---	---	---	---
1.4	2424	1.57	2305	1.40	2032	1.11	---	---	---	---	---	---
1.6	2172	1.38	2017	1.19	---	---	---	---	---	---	---	---
1.8	1953	1.22	---	---	---	---	---	---	---	---	---	---

Note: Tables represent dry coil without filter; to compensate for filter, add 0.08" to measured E.S.P.

AIR FLOW PRESSURE DROP OF DOWN FLOW ECONOMIZER

AIRFLOW PRESSURE DROP OF DOWNFLOW ECONOMIZER FOR 3 TO 6 TON ROFTOP UNITS (100% RETURN AIR)											
SCF,	800	1000	1200	1400	1600	1800	2000	2200	2400	2600	2800
in WG	0.02	0.04	0.05	0.07	0.09	0.12	0.14	0.17	0.21	0.24	0.28

DCH072****V***A*

	OUTDOOR AMBIENT TEMPERATURE																	
	65	60	55	50	47	45	40	35	30	25	20	17	15	10	5	0	-5	-10
MBh	86.7	82.1	77.3	72.2	69.0	66.9	62.1	57.3	47.3	43.7	40.2	38.0	36.6	32.8	29.1	25.4	21.7	17.7
T/R	35.7	33.8	31.8	29.7	28.4	27.5	25.6	23.6	19.5	18.0	16.6	15.6	15.1	13.5	12.0	10.4	8.9	7.3
KW	5.74	5.67	5.60	5.53	5.47	5.38	5.29	5.20	5.12	5.03	4.92	4.84	4.75	4.66	4.58	4.49	4.40	4.31
COP	4.42	4.24	4.04	3.82	3.69	3.64	3.44	3.22	2.71	2.54	2.39	2.30	2.25	2.06	1.86	1.65	1.44	1.20
EER	15.1	14.5	13.8	13.1	12.6	12.4	11.7	11.0	9.2	8.7	8.2	7.9	7.7	7.0	6.4	5.7	4.9	4.1
HI PR	366	351	337	323	315	309	297	285	273	261	250	244	240	231	222	213	205	198
LO PR	173	160	150	138	130	125	115	102	92	83	73	67	65	55	47	40	35	27

Above information is for 2150 CFM & 70° indoor dry bulb; instantaneous capacity listed.

kW = Total system power

High pressure measured at liquid line access fitting.

Amps: Unit Amps (comp+evap motor+condenser fan motor)

Low pressure measured at compressor suction access fitting.

HIGH EFFICIENCY MERV 13 AIR FILTER OPTION

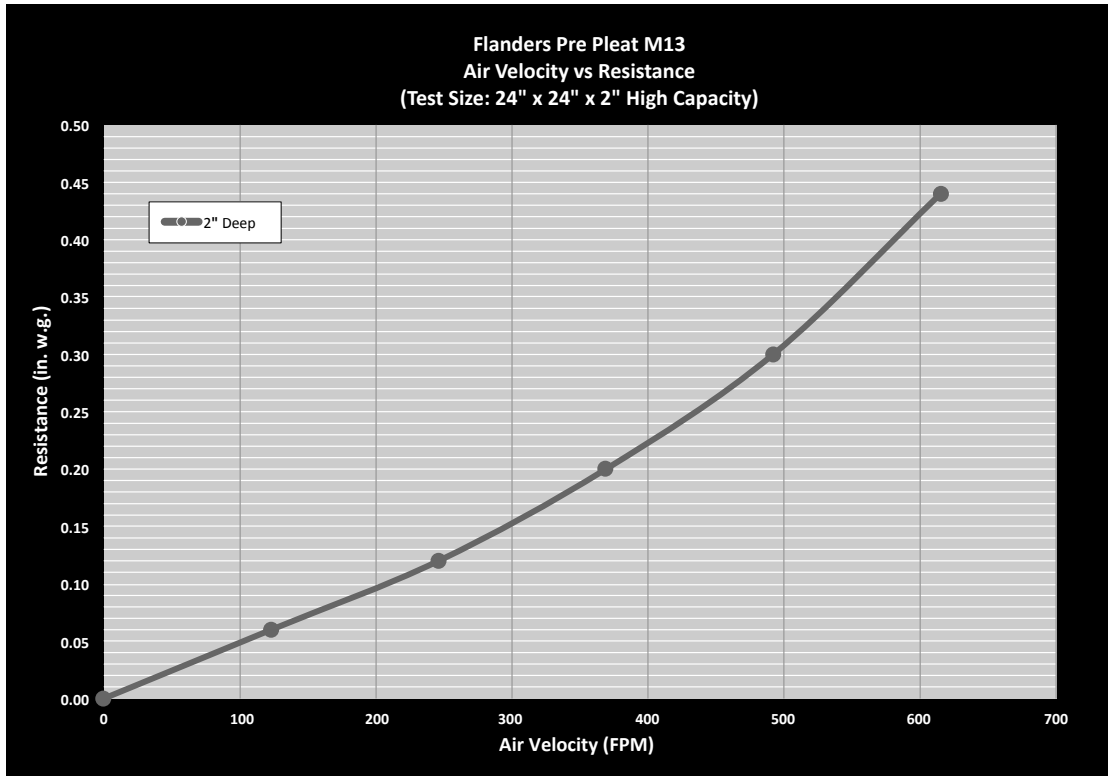

TONNAGE:	FILTER NOMINAL SIZE:	PART NUMBER:	ORDER QTY:
6	16 x 20 x 2	0160L00205	4

CRANKCASE HEATER SELECTION TABLE

ZP/ZPS...	COMPRESSOR DIAMETER	COMPRESSOR VOLTAGE			CRANKCASE HEATER WATTS
		230V	460V	575V	
16-31	5.5"	0163R00002S	0163R00031S	0163R00032S	40
39-83	6.58/7.3"	0130L00017S	0130L00018S	0130L00019S	70
103-137	9.14"	0130L00020S	0130L00021S	0130L00022S	90

DC*,DT* & DS* TONNAGE	COMPRESSOR VOLTAGE			CRANKCASE HEATER WATTS
	230V	460V	575V	
6 Ton	0130L00017S	0130L00018S	0130L00019S	70

*Includes C,G&H models.

MODEL NUMBER	ELECTRICAL RATING	COMPRESSOR CIRCUIT 1		COMPRESSOR CIRCUIT 2		OUTDOOR FAN MOTOR			INDOOR FAN MOTOR			OPTIONAL ELECTRIC HEAT			OPTIONAL POWERED CONVENIENCE OUTLET	UNIT POWER SUPPLY	
		RLA	LRA	RLA	LRA	QTY	HP	FLA	TYPE	HP	FLA	MODEL	KW*	FLA	FLA	MCA	MOP
DCH072XXX3W	208/230-3-60	17.6	136.0			1	0.33	2.0	2-speed High Static Belt Drive	2.00	6.0	-	-	-	-	30.0 / 30.0	45 / 45
												EHK3-10	7.5 / 10.0	20.8 / 24.0	-	56.0 / 60.0	60 / 70
												EHK3-15	11.3 / 15.0	31.3 / 36.1	-	69.0 / 75.1	70 / 80
												EHK3-20	15.0 / 20.0	41.6 / 48.0	-	81.9 / 89.9	90 / 90
												EHK3-25	18.8 / 25.0	52.1 / 60.1	-	95.1 / 105	100 / 110
												-	-	-	7.2 / 6.5	37.2 / 36.5	50 / 50
												EHK3-10	7.5 / 10.0	20.8 / 24.0	7.2 / 6.5	63.2 / 66.5	70 / 70
												EHK3-15	11.3 / 15.0	31.3 / 36.1	7.2 / 6.5	76.2 / 81.6	80 / 90
												EHK3-20	15.0 / 20.0	41.6 / 48.0	7.2 / 6.5	89.1 / 96.4	90 / 100
DCH072XXX3V	208/230-3-60	17.6	136.0			1	0.33	2.0	2-speed Belt Drive	2.00	6.0	-	-	-	-	30.0 / 30.0	45 / 45
												EHK3-10	7.5 / 10.0	20.8 / 24.0	-	56.0 / 60.0	60 / 70
												EHK3-15	11.3 / 15.0	31.3 / 36.1	-	69.0 / 75.1	70 / 80
												EHK3-20	15.0 / 20.0	41.6 / 48.0	-	81.9 / 89.9	90 / 90
												EHK3-25	18.8 / 25.0	52.1 / 60.1	-	95.1 / 105	100 / 110
												-	-	-	7.2 / 6.5	37.2 / 36.5	50 / 50
												EHK3-10	7.5 / 10.0	20.8 / 24.0	7.2 / 6.5	63.2 / 66.5	70 / 70
												EHK3-15	11.3 / 15.0	31.3 / 36.1	7.2 / 6.5	76.2 / 81.6	80 / 90
												EHK3-20	15.0 / 20.0	41.6 / 48.0	7.2 / 6.5	89.1 / 96.4	90 / 100
DCH072XXX4W	460-3-60	8.5	66.1			1	0.33	0.9	2-speed High Static Belt Drive	2.00	6.00	-	-	-	-	14.3	20
												EHK4-10	10.0	12.0	-	29.3	30
												EHK4-15	15.0	18.0	-	36.9	40
												EHK4-20	20.0	24.0	-	44.3	45
												EHK4-25	25.0	30.1	-	51.9	60
												-	-	-	3.3	17.6	25
												EHK4-10	10.0	12.0	3.3	32.6	35
												EHK4-15	15.0	18.0	3.3	40.2	45
												EHK4-20	20.0	24.0	3.3	47.6	50
DCH072XXX4V	460-3-60	8.5	66.1			1	0.33	0.9	2-speed Belt Drive	1.50	2.40	-	-	-	-	14.3	20
												EHK4-10	10.0	12.0	-	29.3	30
												EHK4-15	15.0	18.0	-	36.9	40
												EHK4-20	20.0	24.0	-	44.3	45
												EHK4-25	25.0	30.1	-	51.9	60
												-	-	-	3.3	17.6	25
												EHK4-10	10.0	12.0	3.3	32.6	35
												EHK4-15	15.0	18.0	3.3	40.2	45
												EHK4-20	20.0	24.0	3.3	47.6	50
DCH072XXX7W	575-3-60	6.5	55.3			1	0.33	0.7	2-speed High Static Belt Drive	2.00	3.00	-	-	-	-	11.0	15
												EHK7-10	10.0	10.0	-	23.6	25
												EHK7-15	15.0	15.1	-	29.9	30
												EHK7-20	20.0	20.0	-	36.1	40
												EHK7-25	25.0	25.1	-	42.4	45
												-	-	-	2.6	13.6	20
												EHK7-10	10.0	10.0	2.6	26.2	30
												EHK7-15	15.0	15.1	2.6	32.5	35
												EHK7-20	20.0	20.0	2.6	38.7	40
DCC072XXX7V	575-3-60	6.5	55.3			1	0.33	0.7	2-speed Belt Drive)	2.00	2.90	-	-	-	-	11.0	15
												EHK7-10	10.0	10.0	-	15.5	20
												EHK7-15	15.0	15.1	-	21.8	25
												EHK7-20	20.0	20.0	-	28.0	30
												EHK7-25	25.0	25.1	-	34.4	35
												-	-	-	2.6	13.6	20
												EHK7-10	10.0	10.0	2.6	18.8	20
												EHK7-15	15.0	15.1	2.6	25.1	30
												EHK7-20	20.0	20.0	2.6	31.3	35
EHK7-25	25.0	25.1	2.6	37.6	40												

* Electric Heater kW rating: Rated at 240v for 208-230v units; 480v for 460v units

MODEL AND HEAT KIT USAGE	RECOMMENDED AIRFLOW RANGE
DCH072***3V***	
EHK3-10	2,100 - 2,700 CFM
EHK3-15	2,100 - 2,700 CFM
EHK3-20	2,100 - 2,700 CFM
EHK3-25	2,100 - 2,700 CFM

MODEL AND HEAT KIT USAGE	RECOMMENDED AIRFLOW RANGE
DCH072***4V***	
EHK4-10	2,100 - 2,700 CFM
EHK4-15	2,100 - 2,700 CFM
EHK4-20	2,100 - 2,700 CFM
EHK4-25	2,100 - 2,700 CFM

MODEL AND HEAT KIT USAGE	RECOMMENDED AIRFLOW RANGE
DCH072***7V***	
EHK7-10	2,100 - 2,700 CFM
EHK7-15	2,100 - 2,700 CFM
EHK7-20	2,100 - 2,700 CFM
EHK7-25	2,100 - 2,700 CFM

Note: All heaters have single-point entry kit

KW CORRECTION FACTORS

kW CORRECTION FACTOR FOR 1- & 3-PHASE UNITS					
SUPPLY VOLTAGE	240	230	220	210	208
CORRECTION FACTOR	1	0.92	0.84	0.77	0.75

For other voltage use $\text{voltage}^2 / 240^2$

kW CORRECTION FACTOR FOR 480V UNITS			
ACTUAL VOLTAGE	460	440	430
CORRECTION FACTOR	0.92	0.84	0.8

For other voltage use $\text{voltage}^2 / 480^2$

kW CORRECTION FACTOR FOR 575V UNITS			
SUPPLY VOLTAGE	560	550	540
CORRECTION FACTOR	0.95	0.91	0.88

For other voltage use $\text{voltage}^2 / 575^2$

Multiply rated kW by correction factor to get actual kW

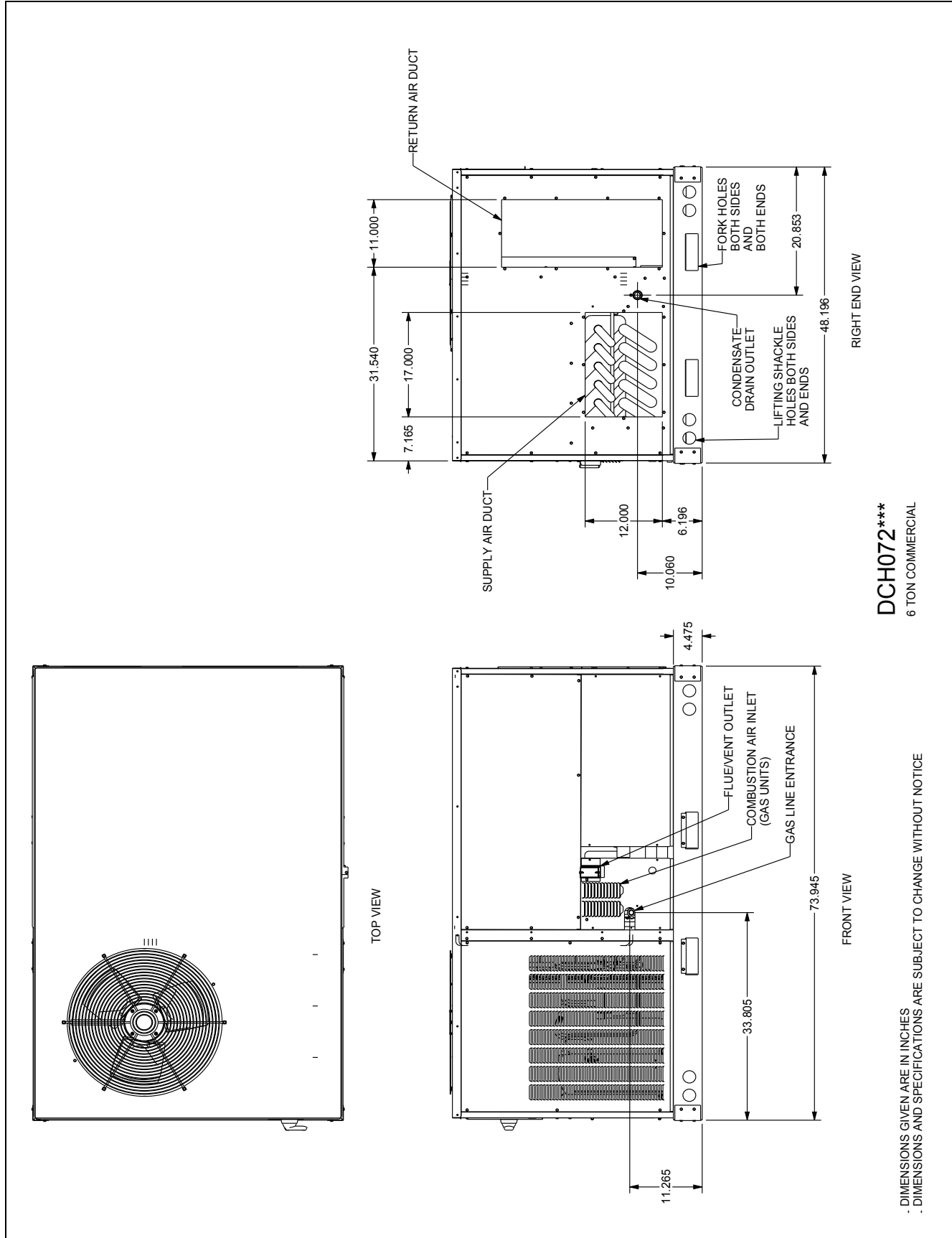

DCH072***
6 TON COMMERCIAL

- DIMENSIONS GIVEN ARE IN INCHES
- DIMENSIONS AND SPECIFICATIONS ARE SUBJECT TO CHANGE WITHOUT NOTICE

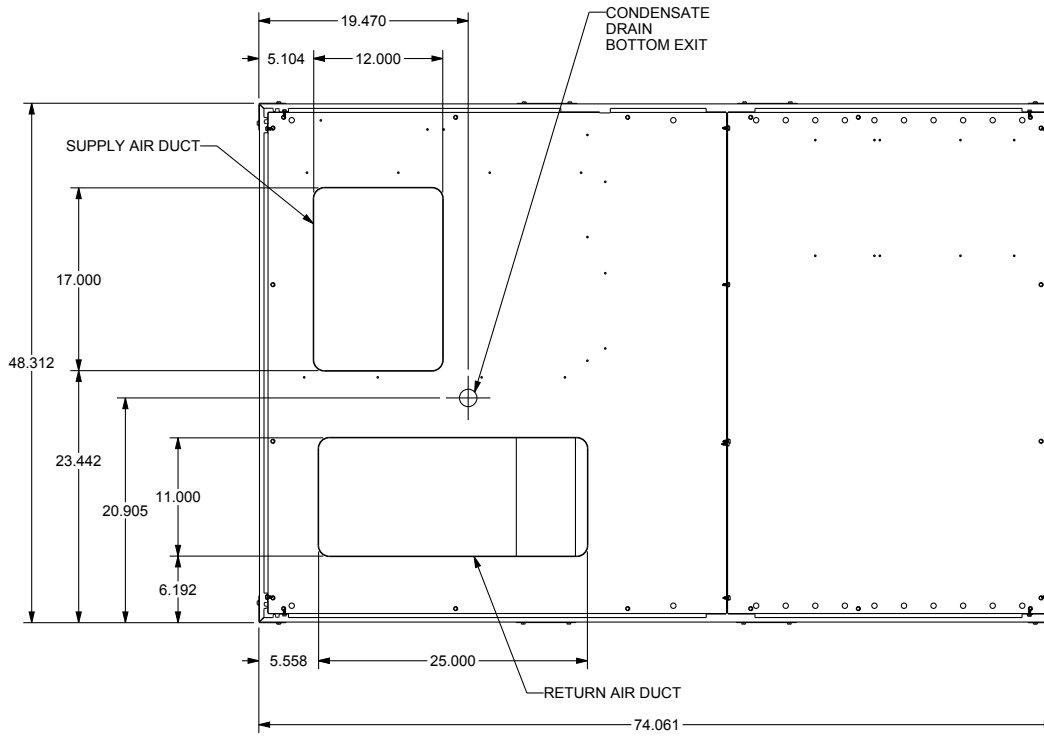

BASE PAN VIEW
(VIEWED FROM TOP)

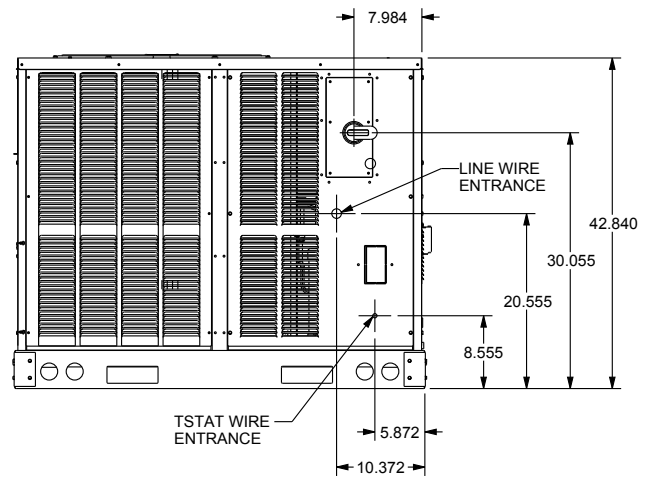

LEFT END VIEW

UNIT CLEARANCES

Maintain an adequate clearance around the unit for safety, service, maintenance, and proper unit operation. Leave a clearance of 48" on all sides of the unit for possible compressor removal or service access, and to ensure proper ventilation and condenser airflow. Do not install the unit beneath any obstruction. Install the unit away from all building exhausts to inhibit ingestion of exhaust air into the unit's fresh-air intake.

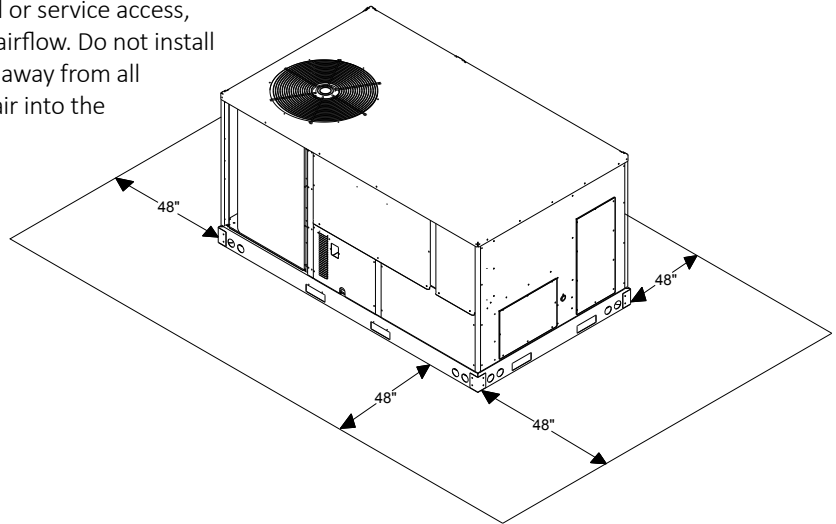

ELECTRICAL ENTRANCE LOCATIONS

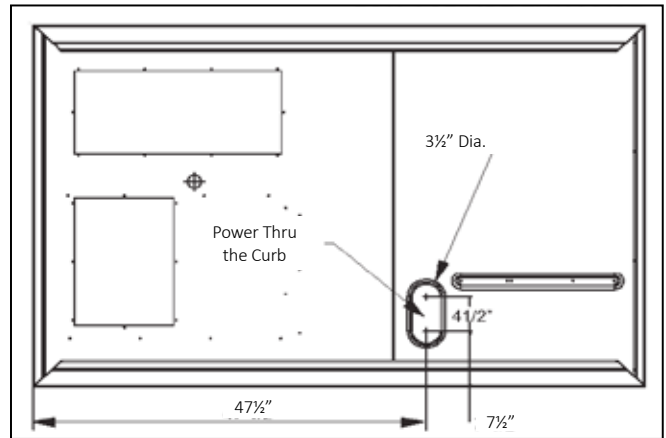
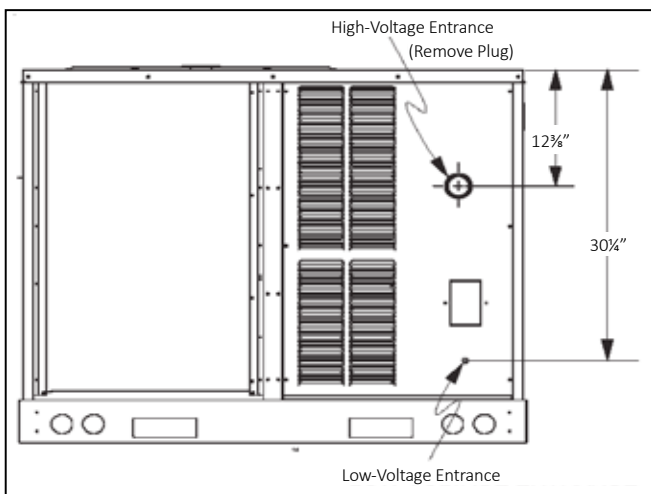

CORNER & CENTER-OF-GRAVITY LOCATIONS

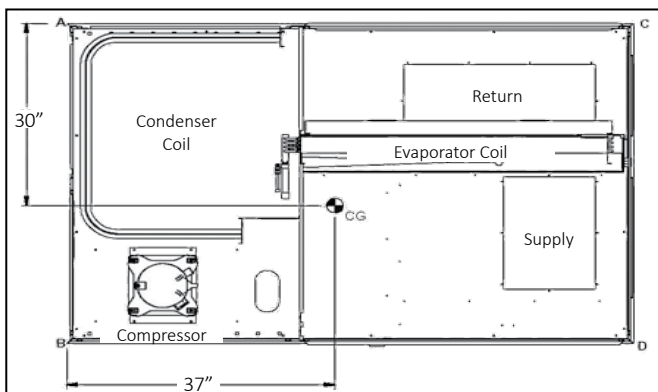

UNIT WEIGHTS	6-TON WEIGHTS
Corner Weight (A)	145
Corner Weight (B)	205
Corner Weight (C)	125
Corner Weight (D)	175
Unit Shipping Weight	675
Unit Operating Weight	650

Note: Weights are calculated without accessories installed.

Provisions for forks have been included in the unit base frame. No other fork locations are approved.

- Unit must be lifted by the four lifting holes located at the base frame corners.
- Lifting cables should be attached to the unit with shackles.
- The distance between the crane hook and the top of the unit must not be less than 60".
- Two spreader bars must span over the unit to prevent damage to the cabinet by the lift cables. Spreader bars must be of sufficient length so that cables do not come in contact with the unit during transport. Remove wood struts mounted beneath unit base frame before setting unit on roof curb. These struts are intended to protect unit base frame from fork lift damage. To remove the struts, extract the sheet metal retainers and pull the struts through the base of the unit. Refer to rigging label on the unit.

Important: If using bottom discharge with roof curb, duct-work should be attached to the curb prior to installing the unit. Duct-work dimensions are shown in Roof Curb Installation Instructions Manual.

Refer to the Roof Curb Installation Instructions for proper curb installation. Curbing must be installed in compliance with the National Roofing Contractors Association Manual.

Lower unit carefully onto roof mounting curb. While rigging the unit, the center of gravity will cause the condenser end to be lower than the supply air end.

Bring condenser end of unit into alignment with the curb. With condenser end of the unit resting on curb member and using curb as a fulcrum, lower opposite end of the unit until entire unit is seated on the curb. When a rectangular cantilever curb is used, take care to center the unit. Check for proper alignment and orientation of supply and return openings with duct.

To assist in determining rigging requirements, unit weights are shown below.

Curb installations must comply with local codes and should follow the established guidelines of the National Roofing Contractors Association.

Proper unit installation requires that the roof curb be firmly and permanently attached to the roof structure. Check for adequate fastening method prior to setting the unit on the curb.

Full perimeter roof curbs are available from the factory and are shipped unassembled. The installing contractor is responsible for field assembly, squaring, leveling, and mounting on the roof structure. All required hardware necessary for the assembly of the sheet metal curb is included in the curb accessory package.

- Determine sufficient structural support before locating and mounting the curb and package unit.
- Duct-work must be constructed using industry guidelines. The duct-work must be placed into the roof curb before mounting the package unit. Our full perimeter curbs include duct connection frames to be assembled with the curb. Cantilevered-type curbs are not available from the factory.
- Contractor furnishes curb insulation, cant strips, flashing, and general roofing material.
- Support curbs on parallel sides with roof members. To prevent damage to the unit, the roof members cannot penetrate supply and return duct openings.

Note: The unit and curb accessories are designed to allow vertical duct installation before unit placement. Duct installation after unit placement is not recommended.

See the manual shipped with the roof curb for assembly and installation instructions.

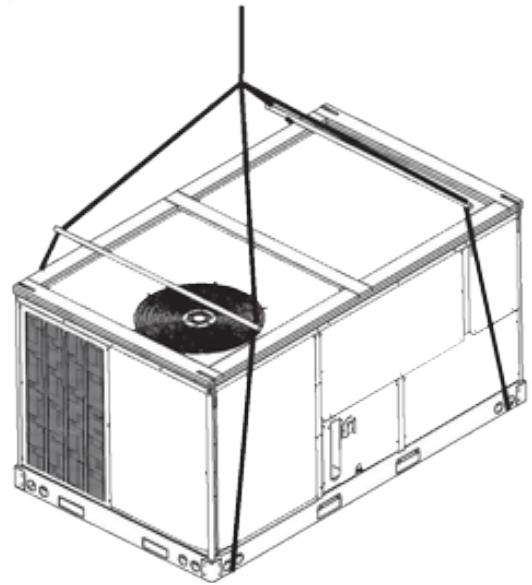

3-D VIEW

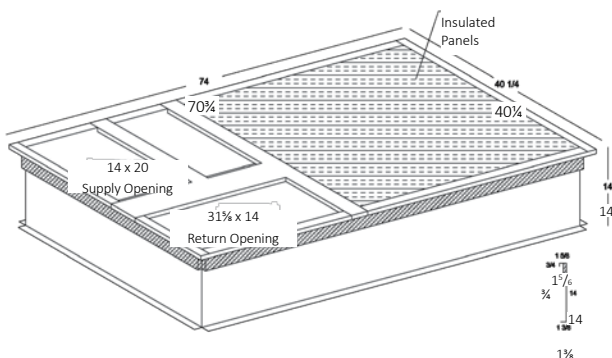

TOP VIEW

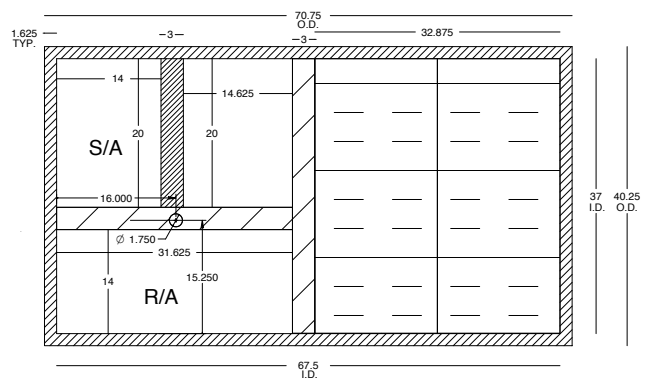

WIRING DIAGRAM — CONTROL DIAGRAM DCH072XXX*V - 2 SPEED (ALL VOLTAGES)

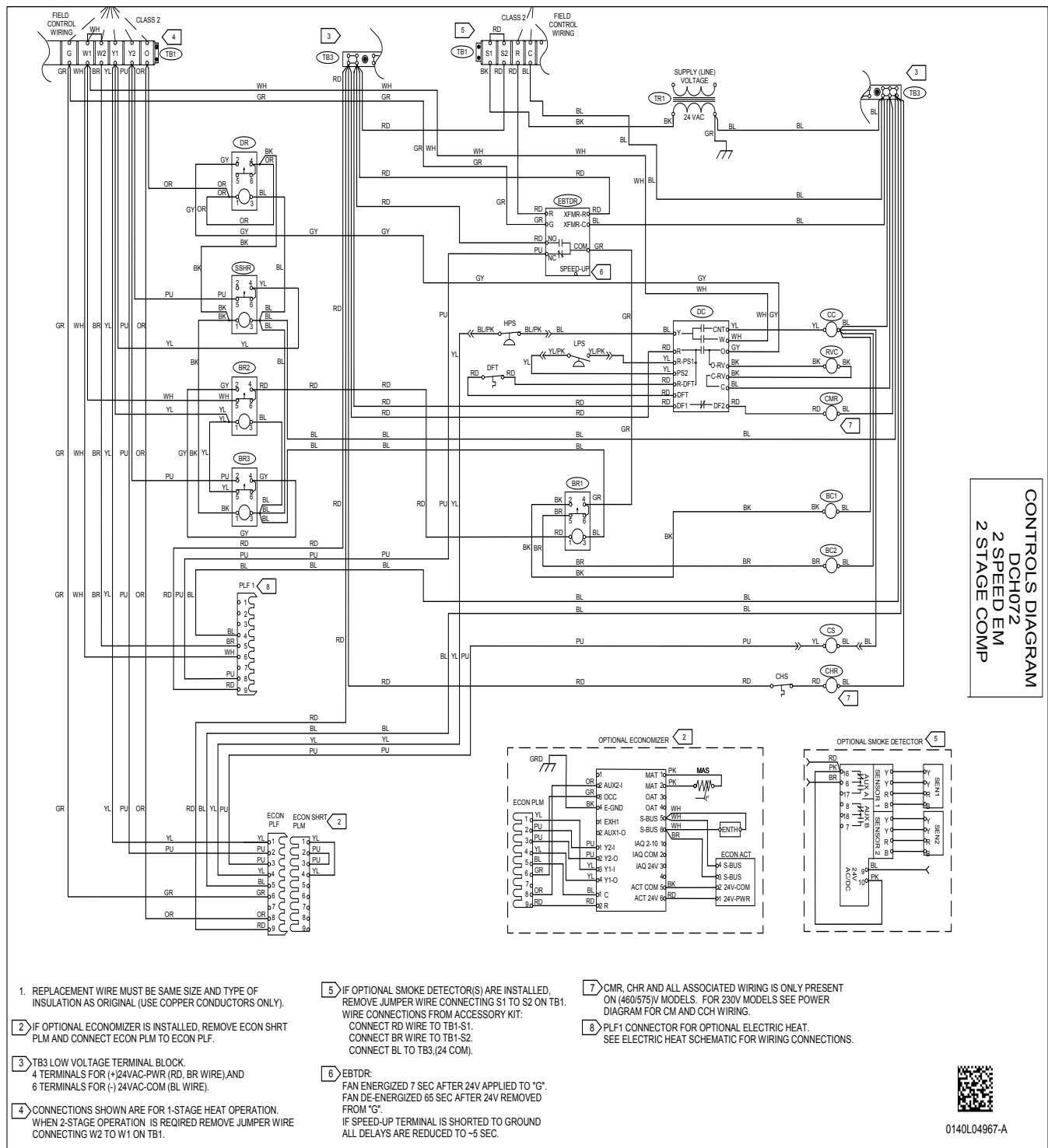

Wiring is subject to change. Always refer to the wiring diagram on the unit for the most up-to-date wiring.

WARNING

High Voltage: Disconnect all power before servicing or installing this unit. Multiple power sources may be present. Failure to do so may cause property damage, personal injury, or death.



0140L04967-A

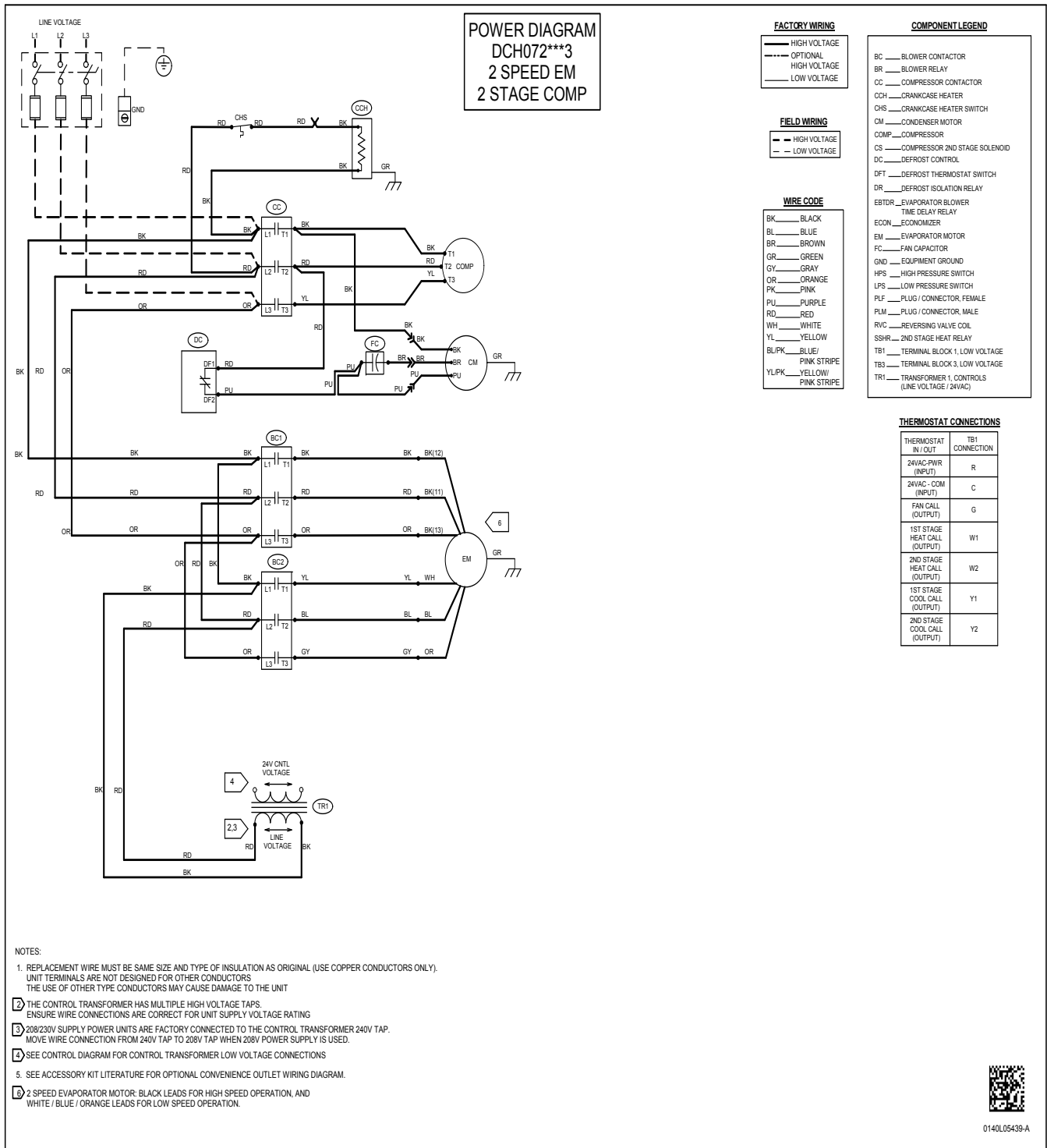

Wiring is subject to change. Always refer to the wiring diagram on the unit for the most up-to-date wiring.



High Voltage: Disconnect all power before servicing or installing this unit. Multiple power sources may be present. Failure to do so may cause property damage, personal injury, or death.



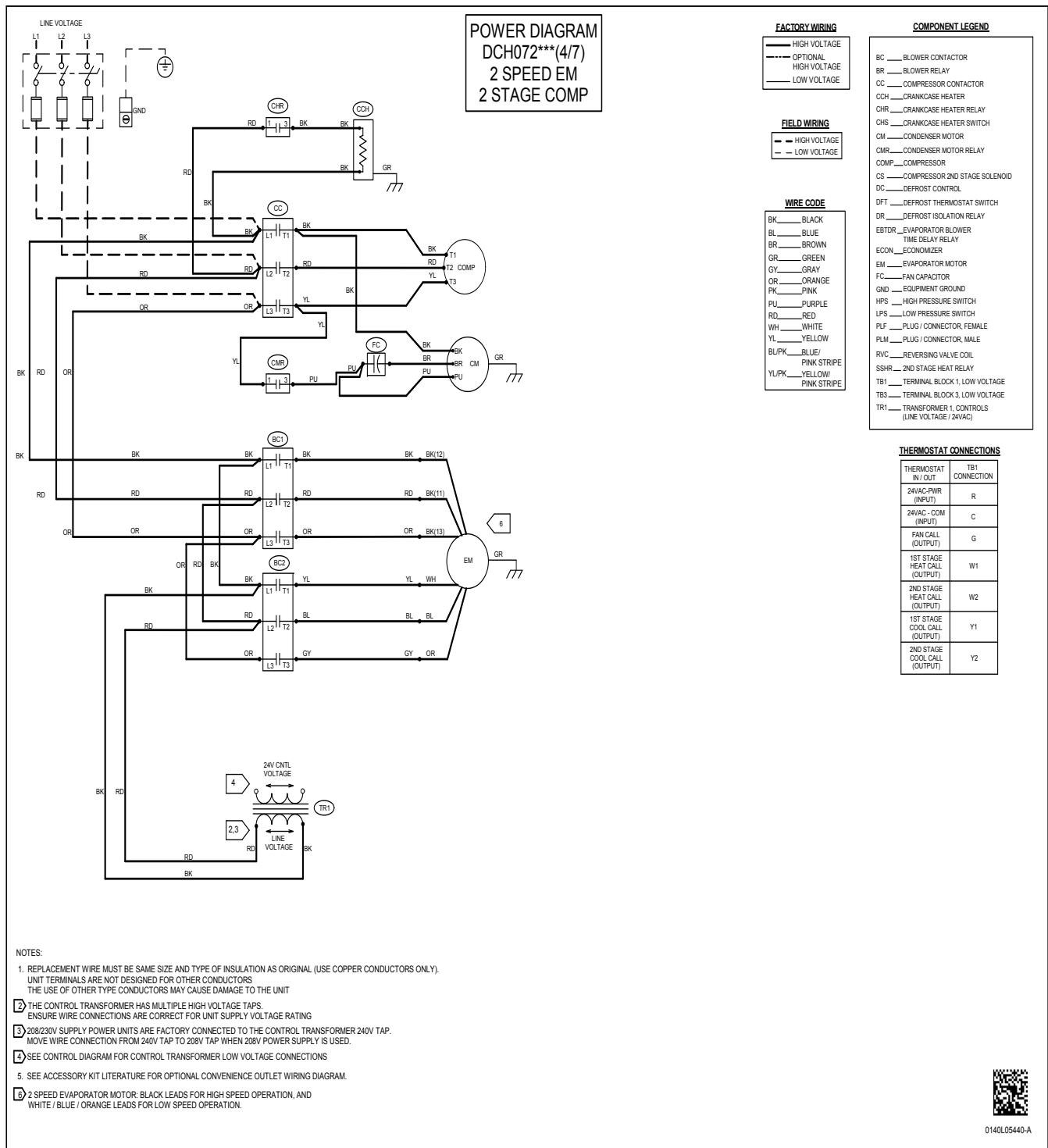

Wiring is subject to change. Always refer to the wiring diagram on the unit for the most up-to-date wiring.

WARNING

High Voltage: Disconnect all power before servicing or installing this unit. Multiple power sources may be present. Failure to do so may cause property damage, personal injury, or death.

WIRING DIAGRAMS FOR MODELS WITH DDC CONTROLS

FOR COMPLETE INFORMATION AND INSTALLATION INSTRUCTIONS FOR MODELS
WITH DDC CONTROLS, SEE MANUAL DK-DDC-TGD-XXX

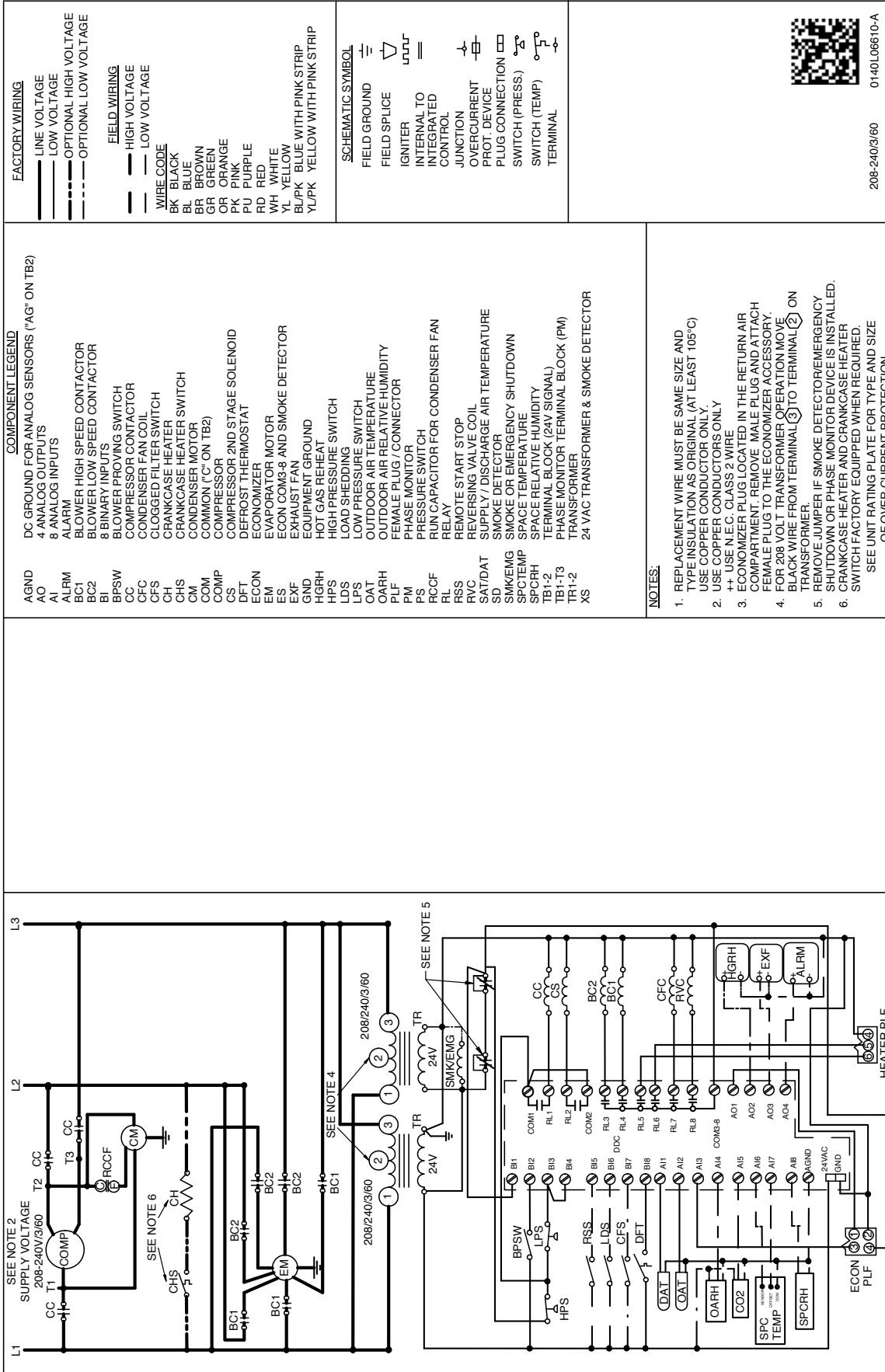

0140L06610-A

208-240/3/60

WARNING

High Voltage: Disconnect all power before servicing or installing this unit. Multiple power sources may be present. Failure to do so may cause property damage, personal injury, or death.

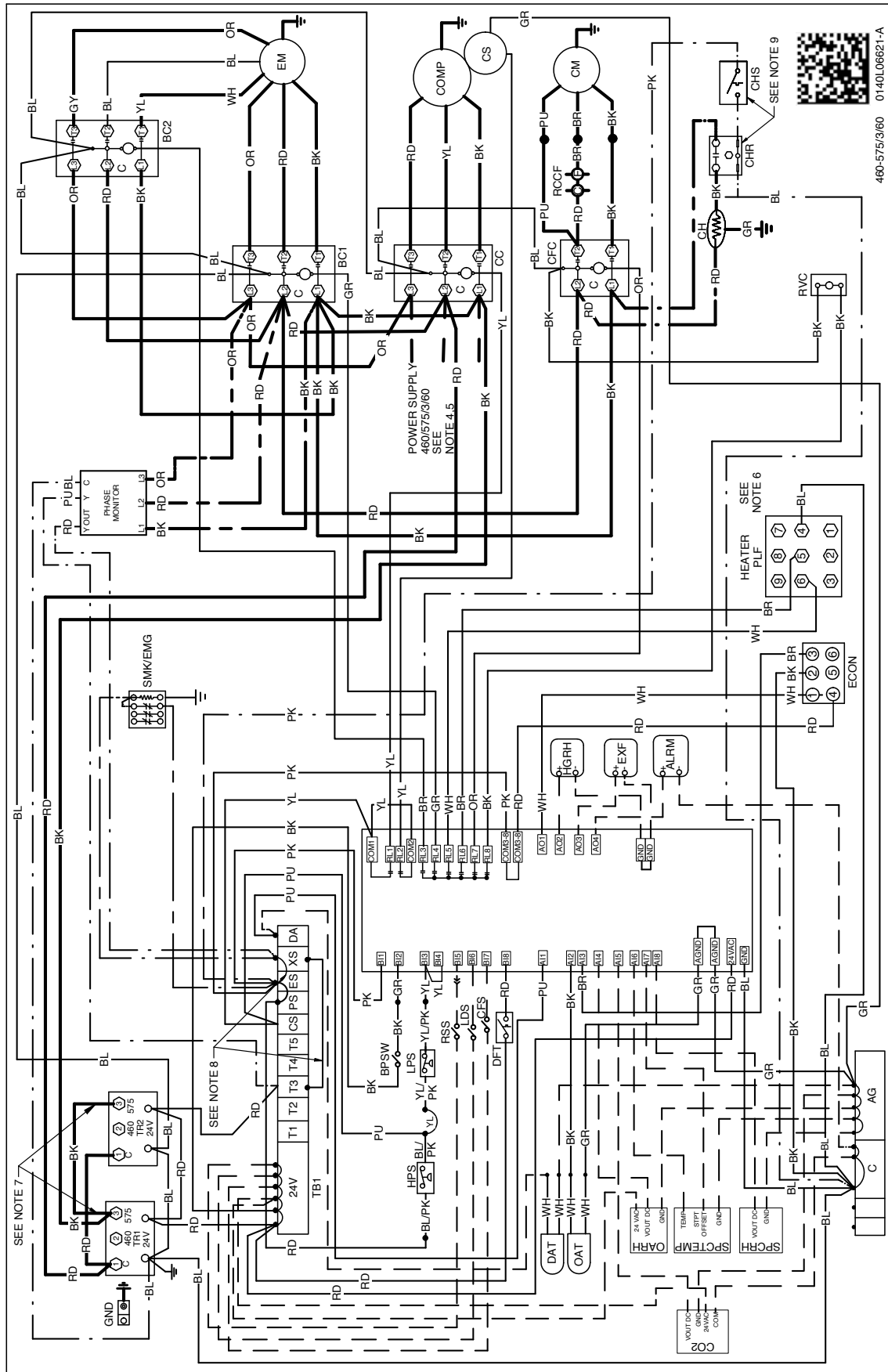

460-575/3/60 0140L06621-A



WARNING

High Voltage: Disconnect all power before servicing or installing this unit. Multiple power sources may be present. Failure to do so may cause property damage, personal injury, or death.

Wiring is subject to change. Always refer to the wiring diagram on the unit for the most up-to-date wiring.

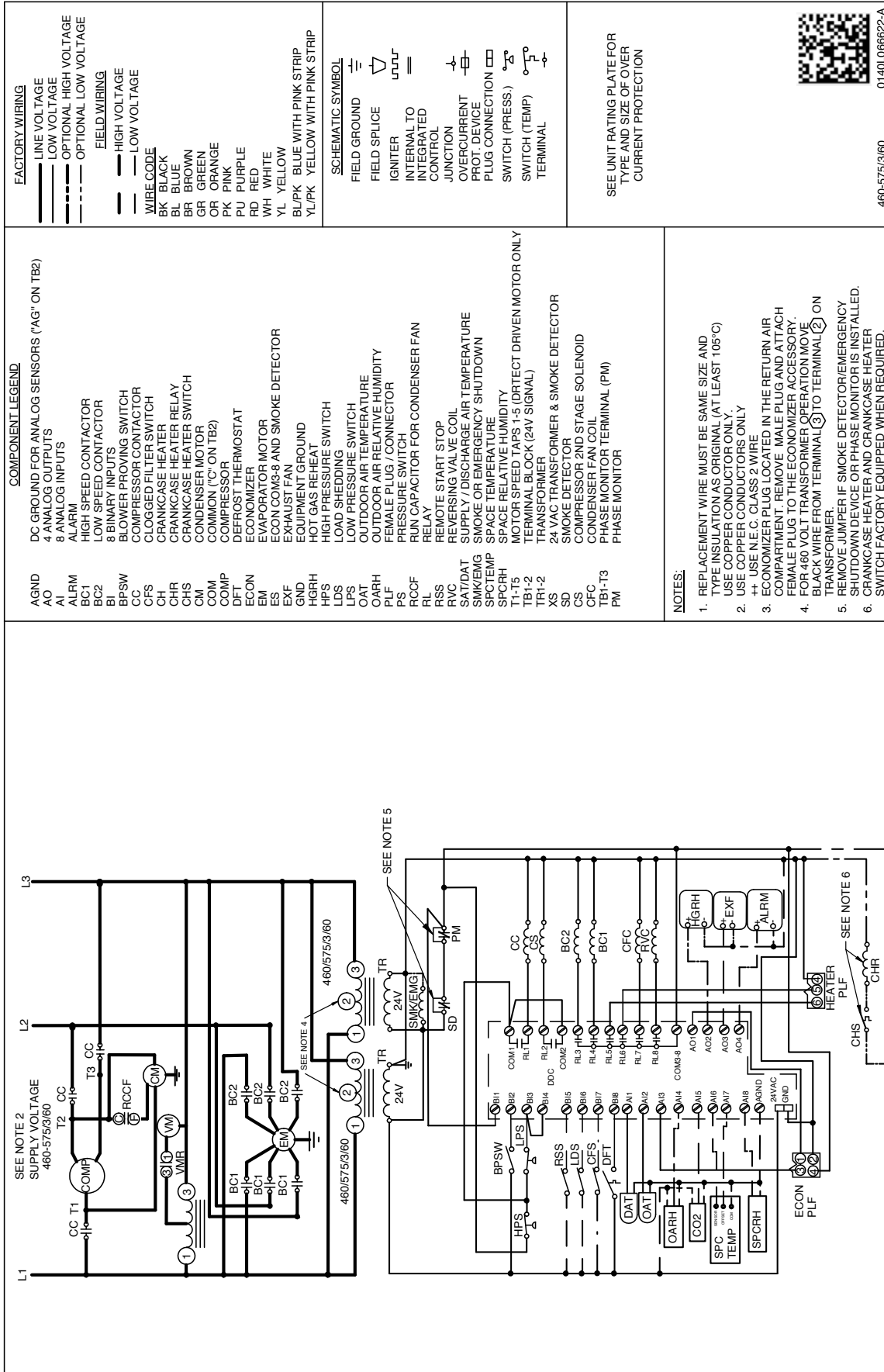

WARNING

High Voltage: Disconnect all power before servicing or installing this unit. Multiple power sources may be present. Failure to do so may cause property damage, personal injury, or death.

Wiring is subject to change. Always refer to the wiring diagram on the unit for the most up-to-date wiring.

DAIKIN MASTER ITEM #	DESCRIPTION	FITS MODEL SIZES	FIELD-INSTALLED	FACTORY-INSTALLED	OPERATING WEIGHT (LBS)
Curb					
14CURB3672B	14" Roof Curb	3-6 tons	√		86
18CURB3672B	18" Roof Curb	3-6 tons	√		100
24CURB3672B	24" Roof Curb	3-6 tons	√		128
GHRC-3672	Hurricane Restraint Clips	3-6 tons	√		2
Ultra Low-Leak Economizer & Power Exhaust¹					
10-455-09A-23	Centrifugal Power Exhaust 230v	3-6 tons	√		60
10-455-09A-33	Centrifugal Power Exhaust 460v	3-6 tons	√		60
01-450-02	Barometric Relief to the Horizontal Economizer	3-6 tons	√		40
1036609C	Ultra Low-Leak Downflow Economizer w/ Enthalpy	3-6 tons	√	√	71
10-396-09	Ultra Low-Leak Horizontal Economizer w/ Enthalpy	3-6 tons	√		71
10-465-09B-21	Prop Power Exhaust 230v	3-6 tons	√		55
10-465-09B-31	Prop Power Exhaust 460v	3-6 tons	√		55
10-465-09B-41	Prop Power Exhaust 575v	3-6 tons	√		55
Low-Leak Economizer & Power Exhaust²					
DDNECNJ3672C	Low-Leak Downflow Economizer	3-6 tons	√	√	82
DPE36722	Downflow Power Exhaust (208/230 Volt)	3-6 tons	√		55
DPE36724	Downflow Power Exhaust (460 Volt)	3-6 tons	√		55
DPE36727	Downflow Power Exhaust (575v)	3-6 tons	√		55
DINH3672B	Horizontal Economizer, Internally Mounted	3-5 tons	√		90
DHZEENJ3672	Horizontal Economizer	3-6 tons	√		70
DHPE36722	Horizontal Power Exhaust (208/230 Volt)	3-6 tons	√		55
DHPE36724	Horizontal Power Exhaust (460 Volt)	3-6 tons	√		55
DHPE36727	Horizontal Power Exhaust (575 Volt)	3-6 tons	√		55
Downflow Accessories					
D25FD3672	25% Manual Fresh Air Damper	3-6 tons	√		12
D25MFD3672	25% Motorized Fresh Air Damper	3-6 tons	√		16
DNBBS3672B	Burglar Bar Sleeves with Supply & Return	3-6 tons	√		30
DDNECNJ3672NR	Downflow Economizer2 w/o Barometric Relief	3-6 Tons	√		77
DDNSQRD487218	Downflow Square-to-Round Adapter (18" Round)	4-6 tons	√		35
Horizontal Accessories					
DBRD3672	Barometric Relief Damper	3-6 tons	√		15
Concentrics					
CDK36	Concentric Duct Kit	3-tons	√		27
CDK36515	Concentric Duct Kit Flush Mount w/Filter	3-tons	√		27
CDK4872	Concentric Duct Kit	4-6 tons	√		27
DDC Accessories³					
	DDC communicating controller (built-in BACnet® MS/TP) includes Standard Room Sensor to be installed in field	3-6 tons		√	2
10366D09C	DDC Ultra Low-Leak Downflow Economizer	3-6 tons	√	√	71
10396D09	DDC Ultra Low-Leak Horizontal Economizer	3-6 tons	√		71

DAIKIN MASTER ITEM #	DESCRIPTION	FITS MODEL SIZES	FIELD-INSTALLED	FACTORY-INSTALLED	OPERATING WEIGHT (LBS)
10465DDC	Power Exhaust kit used with DDC Ultra Low-Leak Economizer	3-6 tons	√		1
DLAKT01	Low-Ambient	3-6 tons	√	√	2
LONKT01	LonWorks® card	3-6 tons	√		1
3PMK01	Phase Monitor (3-Phase Only)	3-6 tons	√	√	2
DFSKT01	Dirty Filter Switch	3-6 tons	√		1
	3 phase 208-230V Electric Heat Kits				
SPKT02	Single Point Wiring Kit 3phase Heat Kits	3-6 tons	√	√	
EHK3-10	10kw 208-230 3ph Electric Heat Kit	3-6 tons	√	√	21
EHK3-15	15kw 208-230 3ph Electric Heat Kit	3-6 tons	√	√	21
EHK3-25	25kw 208-230 3ph Electric Heat Kit	6 tons	√	√	21
	3 phase 460V Electric Heat Kits				
EHK4-10	10kw 460v 3ph Electric Heat Kit	3-6 tons	√	√	21
EHK4-15	15kw 460v 3ph Electric Heat Kit	3-6 tons	√	√	21
EHK4-25	25kw 460v 3ph Electric Heat Kit	6 tons	√	√	21
	3 phase 575V Electric Heat Kits				
EHK7-10	10kw 575v 3ph Electric Heat Kit	3-6 tons	√	√	21
EHK7-15	15kw 575v 3ph Electric Heat Kit	3-6 tons	√	√	21
EHK7-25	25kw 575v 3ph Electric Heat Kit	6 tons	√	√	21
	High-Static Kits				
HSKTW072FI	High-Static Kit (230/460/575v)	6 tons		√	15
	Crankcase Heater Kits				
0130L00017S	70W 230V	4 - 6 tons	√		1
0130L00018S	70W 460V	4 - 6 tons	√		1
0130L00019S	70W 575V	4 - 6 tons	√		1
	High Efficiency Filters				
0160L00205	High Efficiency MERV 13 Air Filter Nom. Size: 16x20x2; (Order Qty 4)	5 & 6 tons	√		4
	Misc Accessories				
HAILGD03D	Condenser Hail Guard	3-5 tons	√		22
HAILGD04D	Condenser Coil Hail Guard	6 tons	√		22
	Convenience Outlet: Non Powered	3-6 tons		√	2
	Convenience Outlet: Powered	3-6 tons		√	42
	Disconnect Switch	3-6 tons		√	5
LAKT12	Low Ambient Kit, 208-230V - non-DDC	3-6 tons	√	√	14
LAKT15	Low Ambient Kit, 460V - non-DDC	3-6 tons	√	√	14
LAKT16	Low Ambient Kit, 575V - non-DDC	3-6 tons	√	√	14
3PMNDK01	Phase Monitor - Non DDC	3-6 tons	√	√	2
	Smoke Detector (supply and/or return air)	3-6 tons		√	11
	Hinged Panels	3-6 tons		√	10

¹ Use Economizer & Power Exhaust listed within Ultra Low-Leak section

² Use Economizer & Power Exhaust listed within Low-Leak section

³ For a full list of DDC accessories, please refer to DDC Controller Technical Guide manual (DK-DDC-TGD-01B)

Note: Where multiple variations are available, the heaviest combination is listed.

