

# INDOOR COILS

## CAUF, CAPE, CAPT, CHPF, AND CSCF

### CASED, PAINTED UPFLOW/DOWNFLOW, UNCASED UPFLOW/ DOWNFLOW, HORIZONTAL "A", AND HORIZONTAL SLAB INDOOR COILS

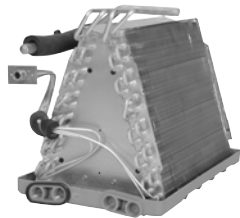

**CAUF**  
 Uncased



**CAPE**  
 Cased



**CHPF**  
 Horizontal "A"

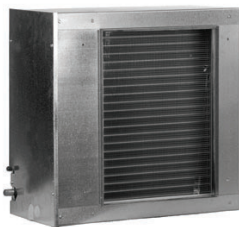

**CSCF**  
 Horizontal Slab



**CAPT**  
 Cased with TXV Option

#### Standard Features

- Piston models suitable for use with R-410A and R-22 refrigerants
- Mold-resistant thermoplastic drain pans feature a low water-retention design
- Check flowrate expansion device for heat pump or cooling-only applications
- Rifled aluminum tubing and louvered aluminum fin coils
- Factory-installed TXV in high-efficiency coils for use with R-410A refrigerant
- AHRI Certified; ETL Listed

#### Cased Coil Cabinet Features

- Galvanized-steel cabinet with leather-grain finish
- Foil-face insulation
- Architectural Gray paint finish on cased coils
- Split-seam front for easy access
- 17½", 21", and 24½" CHPF coils have one 3½" adapter plate
- 17½", 21", and 24½" CAPE coils have two 1¾" adapter plates



\* Complete warranty details available from your local dealer or at [www.amana-hac.com](http://www.amana-hac.com). To receive the 10-Year Parts Limited Warranty, online registration must be completed within 60 days of installation. Online registration is not required in California or Québec.

**Note:** Do not use these coils on oil furnaces or any applications where the temperature on the drain pan may exceed 300°F. If these coils are applied with an oil furnace or another application where high temperatures threaten or jeopardize the durability of the drain pan, you must replace the factory-installed drain pan with a high-temperature drain pan. High-temperature drain pan kits are available as field-installed accessories.

NOMENCLATURE

	C	A	U	F	1824	A	6	AA			
	1	2	3	4	5,6,7,8	9	10	11,12			
<b>Product Category</b>									<b>Engineering</b>		
C Indoor Coil									Major/Minor Revisions		
<b>Application</b>									<b>Refrigerant</b>		
A Upflow/Downflow Coil									6 R-22 or R-410A		
H Horizontal A Coil									2 R-22		
S Horizontal Slab Coil									4 R-410A		
<b>Cabinet Finish</b>										<b>Nominal Width for Gas Furnace</b>	
U Uncased										A Fits 14" Furnace Cabinet	
P Painted										B Fits 17½" Furnace Cabinet	
C Unpainted										C Fits 21" Furnace Cabinet	
<b>Expansion Device</b>											D Fits 24½" Furnace Cabinet
F Flowrator											N Does Not Apply (horizontal slab coil)
T TXV											<b>Nominal Capacity Range @ 13 SEER</b>
											1824 1½ to 2 Tons
											3030 2½ Tons
											3642 3 to 3½ Tons

# CAUF — UNCASSED UPFLOW/DOWNFLOW INDOOR COILS



## SPECIFICATIONS

MODEL	DIMENSIONS			NOMINAL TONS	CONNECTION		PISTON SIZE*	SHIP WEIGHT (LBS)
	W	H	A		LIQUID	SUCTION		
CAUF1824A6	13"	16 1/4"	13"	1 1/2-2	3/8"	3/4"	.059	18
CAUF1824B6	16 1/2"	16 1/4"	13"	1 1/2-2	3/8"	3/4"	.059	23
CAUF1824C6	20"	16 3/8"	17"	1 1/2-2	3/8"	3/4"	.059	27
CAUF3030A6	13"	20 1/16"	17"	2 1/2	3/8"	3/4"	.065	25
CAUF3030B6	16 1/2"	18 3/4"	17"	2 1/2	3/8"	3/4"	.065	22
CAUF3030C6	20"	17 7/8"	17"	2 1/2	3/8"	3/4"	.065	25
CAUF3030D6	23"	17 7/8"	17"	2 1/2	3/8"	3/4"	.065	32
CAUF3131B6	16 1/2"	20 1/16"	17"	2 1/2	3/8"	3/4"	.068	27
CAUF3131C6	20"	20"	17"	2 1/2	3/8"	3/4"	.068	31
CAUF3636A6	13"	19 1/2"	17"	3	3/8"	3/4"	.071	30
CAUF3636B6	16 1/2"	19 3/8"	17"	3	3/8"	3/4"	.071	25
CAUF3636C6	20"	19 3/8"	17"	3	3/8"	3/4"	.071	28
CAUF3636D6	23"	19 3/8"	17"	3	3/8"	3/4"	.071	36
CAUF3642C6	20"	19"	17"	3-3 1/2	3/8"	3/4"	.078	29
CAUF3642D6	23"	19 3/8"	17"	3-3 1/2	3/8"	3/4"	.078	34
CAUF3743C6	20"	28 1/16"	25"	3-3 1/2	3/8"	7/8"	.078	46
CAUF3743D6	23"	27 3/8"	25"	3-3 1/2	3/8"	7/8"	.078	43
CAUF4860C6	20"	28"	25"	4-5	3/8"	7/8"	.093	48
CAUF4860D6	23"	28"	25"	4-5	3/8"	7/8"	.093	39
CAUF4961C6	20"	28"	25"	4-5	3/8"	7/8"	.093	54
CAUF4961D6	23"	27"	25"	4-5	3/8"	7/8"	.093	59

\* Shipped with Coil

Note: For a properly matched system and piston sizing information, refer to Amana piston kit chart of the corresponding Amana® outdoor unit.

## DIMENSIONS

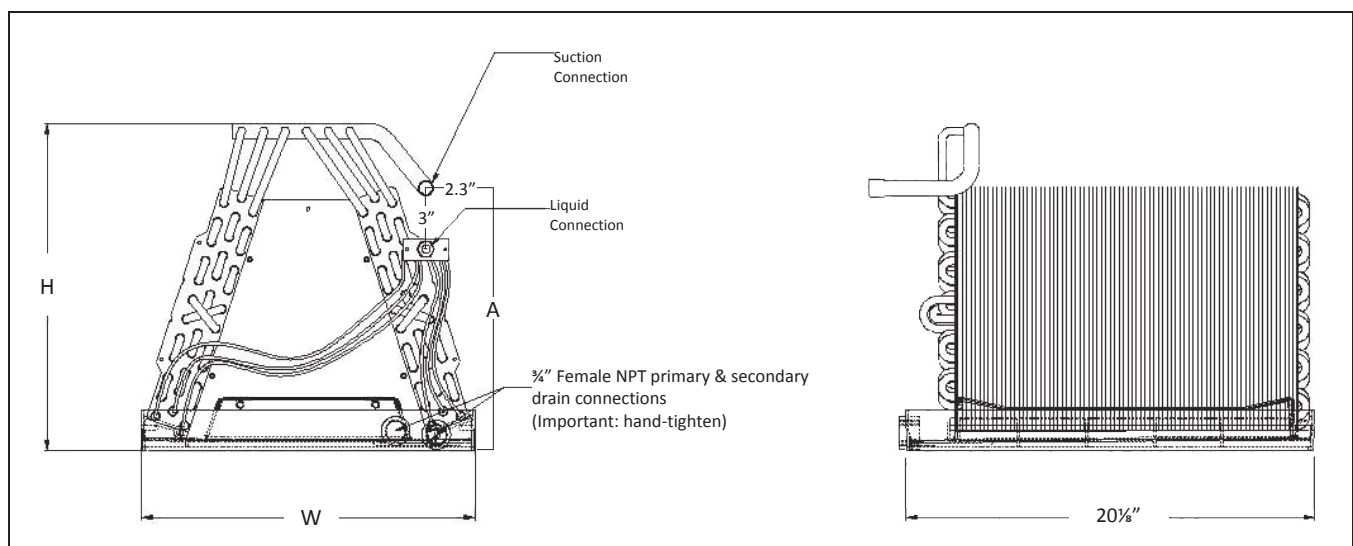

# CAPF — CASED UPFLOW/DOWNFLOW INDOOR COILS



## SPECIFICATIONS

MODEL	CABINET DIMENSIONS			NOMINAL TONS	CONNECTION		PISTON SIZE*	SHIP WEIGHT (LBS)
	W	D	H		LIQUID	SUCTION		
CAPF1824A6	14"	21"	18"	1½-2	¾"	¾"	.059	32
CAPF1824B6	17½"	21"	18"	1½-2	¾"	¾"	.059	35
CAPF1824C6	21"	21"	22"	1½-2	¾"	¾"	.059	42
CAPF3030A6	14"	21"	22"	2½	¾"	¾"	.065	41
CAPF3030B6	17½"	21"	22"	2½	¾"	¾"	.065	43
CAPF3030C6	21"	21"	22"	2½	¾"	¾"	.065	44
CAPF3030D6	24½"	21"	22"	2½	¾"	¾"	.065	52
CAPF3131B6	17½"	21"	22"	2½	¾"	¾"	.068	46
CAPF3131C6	21"	21"	22"	2½	¾"	¾"	.068	50
CAPF3636A6	14"	21"	22"	3	¾"	¾"	.071	40
CAPF3636B6	17½"	21"	22"	3	¾"	¾"	.071	44
CAPF3636C6	21"	21"	22"	3	¾"	¾"	.071	53
CAPF3636D6	24½"	21"	22"	3	¾"	¾"	.071	51
CAPF3642C6	21"	21"	22"	3-3½	¾"	¾"	.078	49
CAPF3642D6	24½"	21"	22"	3-3½	¾"	¾"	.078	52
CAPF3743C6	21"	21"	30"	3-3½	¾"	7/8"	.078	63
CAPF3743D6	24½"	21"	30"	3-3½	¾"	7/8"	.078	75
CAPF4860C6	21"	21"	30"	4-5	¾"	7/8"	.093	65
CAPF4860D6	24½"	21"	30"	4-5	¾"	7/8"	.093	68
CAPF4961C6	21"	21"	30"	4-5	¾"	7/8"	.093	73
CAPF4961D6	24½"	21"	30"	4-5	¾"	7/8"	.093	76

\* Shipped with Coil

Note: For a properly matched system and piston sizing information, refer to Amana piston kit chart of the corresponding Amana® outdoor unit.

## DIMENSIONS

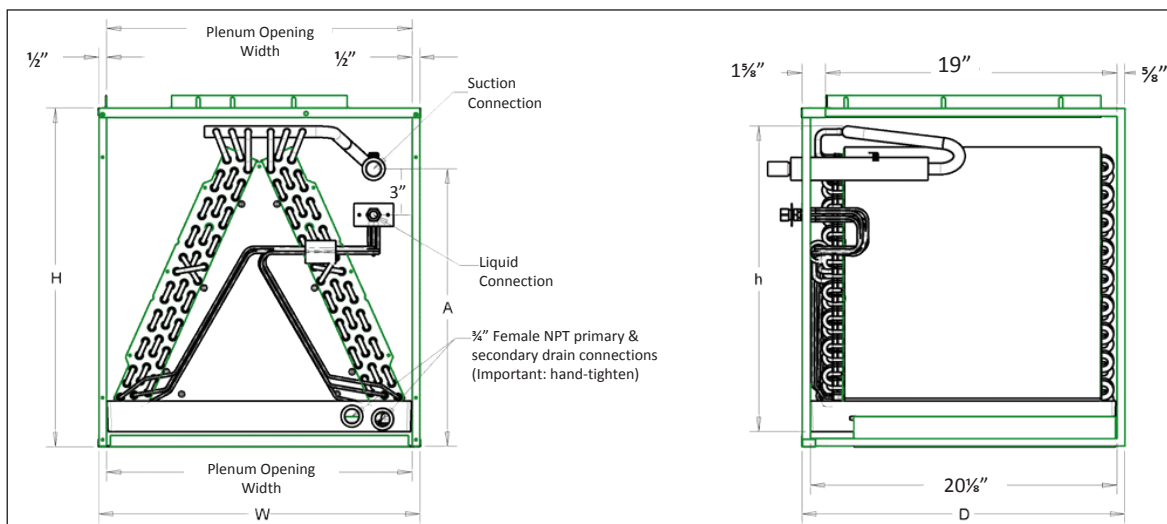

# CAPT — CASED UPFLOW/DOWNFLOW INDOOR COILS WITH TXV OPTION



## SPECIFICATIONS

MODEL	CABINET DIMENSIONS			NOMINAL TONS	CONNECTION		SHIP WEIGHT (LBS)
	W	D	H		LIQUID	SUCTION	
CAPT3131B4	17½"	21"	22"	2½	⅜"	¾"	46
CAPT3131C4	21"	21"	22"	2½	⅜"	¾"	50
CAPT3743C4	21"	21"	30"	3-3½	⅜"	7⁄8"	63
CAPT3743D4	24½"	21"	30"	3-3½	⅜"	7⁄8"	75
CAPT4961C4	21"	21"	30"	4-5	⅜"	7⁄8"	73
CAPT4961D4	24½"	21"	30"	4-5	⅜"	7⁄8"	76

## DIMENSIONS

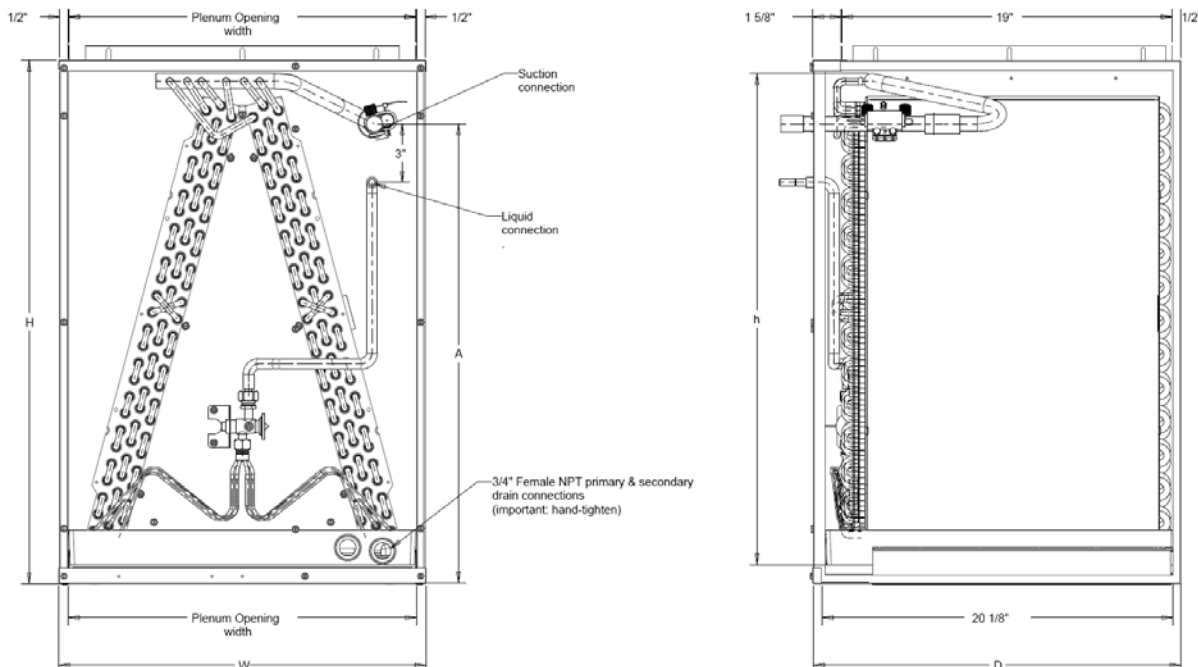

# CHPF — PAINTED CASED HORIZONTAL “A” INDOOR COIL



## SPECIFICATIONS

MODEL	CABINET DIMENSIONS			PLENUM		NOMINAL TONS	EVAP COIL FACE AREA <sup>1</sup>	COIL DIMENSIONS		CONNECTION		PISTON SIZE <sup>2</sup>	SHIP WEIGHT (LBS)
	W	D	H	W	H			W	H	LIQUID	SUCTION		
CHPF1824A6	21 $\frac{1}{8}$ "	26"	14"	19"	13"	1½-2	3 $\frac{3}{8}$	20 $\frac{1}{4}$ "	12"	$\frac{3}{8}$ "	$\frac{3}{4}$ "	.059	36
CHPF2430B6	21 $\frac{1}{8}$ "	26"	17 $\frac{1}{2}$ "	19"	16 $\frac{1}{2}$ "	2-2½	4 $\frac{1}{2}$	20 $\frac{1}{4}$ "	16"	$\frac{3}{8}$ "	$\frac{3}{4}$ "	.065	55
CHPF3636B6	21 $\frac{1}{8}$ "	26"	17 $\frac{1}{2}$ "	19"	16 $\frac{1}{2}$ "	3	4 $\frac{3}{8}$	19 $\frac{1}{2}$ "	16"	$\frac{3}{8}$ "	$\frac{3}{4}$ "	.074	50
CHPF3642C6	21 $\frac{1}{8}$ "	26"	21"	19"	20"	3-3½	4 $\frac{3}{8}$	19 $\frac{1}{2}$ "	16"	$\frac{3}{8}$ "	$\frac{3}{4}$ "	.076	63
CHPF3642D6	21 $\frac{1}{8}$ "	26"	24 $\frac{1}{2}$ "	19"	23 $\frac{1}{2}$ "	3-3½	6	19 $\frac{1}{2}$ "	22"	$\frac{3}{8}$ "	$\frac{7}{8}$ "	.078	66
CHPF3743C6	21 $\frac{1}{8}$ "	26"	21"	19"	20"	3-3½	4 $\frac{3}{8}$	19 $\frac{1}{2}$ "	16"	$\frac{3}{8}$ "	$\frac{7}{8}$ "	.076	63
CHPF3743D6	21 $\frac{1}{8}$ "	26"	24 $\frac{1}{2}$ "	19"	23 $\frac{1}{2}$ "	3-3½	6	19 $\frac{1}{2}$ "	22"	$\frac{3}{8}$ "	$\frac{7}{8}$ "	.078	63
CHPF4860D6	21 $\frac{1}{8}$ "	26"	24 $\frac{1}{2}$ "	19"	23 $\frac{1}{2}$ "	4-5	6	19 $\frac{1}{2}$ "	22"	$\frac{3}{8}$ "	$\frac{7}{8}$ "	.093	77

<sup>1</sup> (ft<sup>2</sup>)

<sup>2</sup> Shipped with Coil

Note: For a properly matched system and piston sizing information, refer to Amana piston kit chart of the corresponding Amana® outdoor unit.

## DIMENSIONS

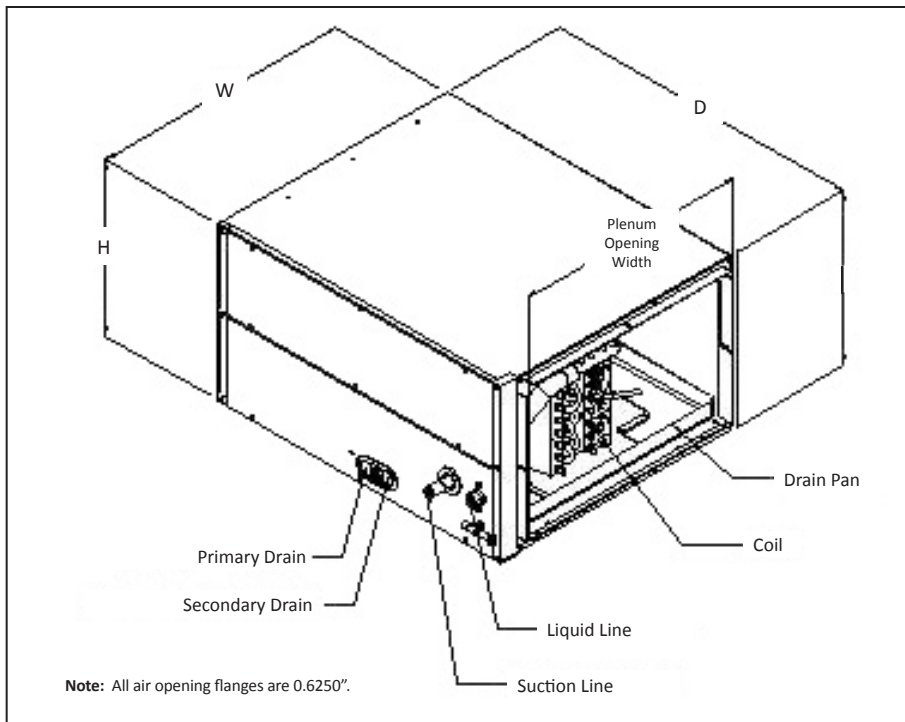

# CSCF — HORIZONTAL SLAB EVAPORATOR COILS



## SPECIFICATIONS

MODEL	CAPACITY (TONS)	EVAP COIL FACE AREA <sup>1</sup>	CONNECTION SIZE		PISTON SIZE <sup>2</sup>	SHIP WEIGHT (LBS)
			LIQUID	SUCTION		
CSCF1824N6	1½-2	3½	⅜"	¼"	.059	43
CSCF3036N6	2½-3	4½	⅜"	⅝"	.074	52.5
CSCF3642N6	3-3½	5½	⅜"	⅝"	.078	43
CSCF4860N6	4-5	5½	⅜"	⅝"	.093	60

<sup>1</sup> (ft<sup>2</sup>)

<sup>2</sup> Shipped with Coil

Note: For a properly matched system and piston sizing information, refer to Amana piston kit chart of the corresponding Amana® outdoor unit.

## DIMENSIONS

MODEL	CABINET DIMENSIONS			PLENUM OPENING		C WIDTH	COIL DIMENSIONS	
	W (A)	D	H	W (B)	H		W	H
CSCF1824N6	25½"	12"	25"	16"	21"	6"	19¾"	24"
CSCF3036N6	33½"	12"	25"	24"	21"	6"	28"	24"
CSCF3642N6	39½"	12"	25"	30"	21"	6"	34"	24"
CSCF4860N6	39½"	12"	25"	30"	21"	6"	34"	24"

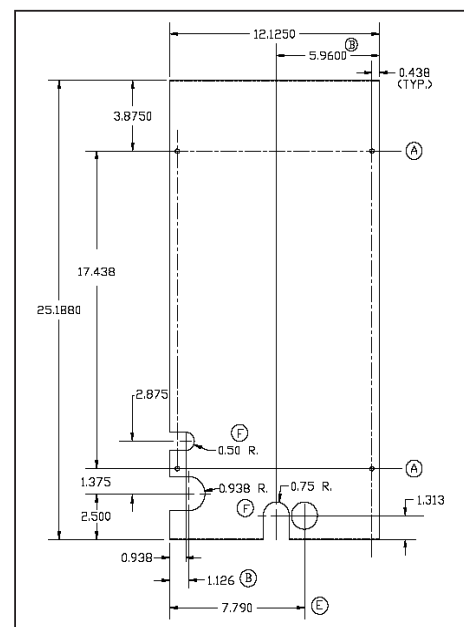
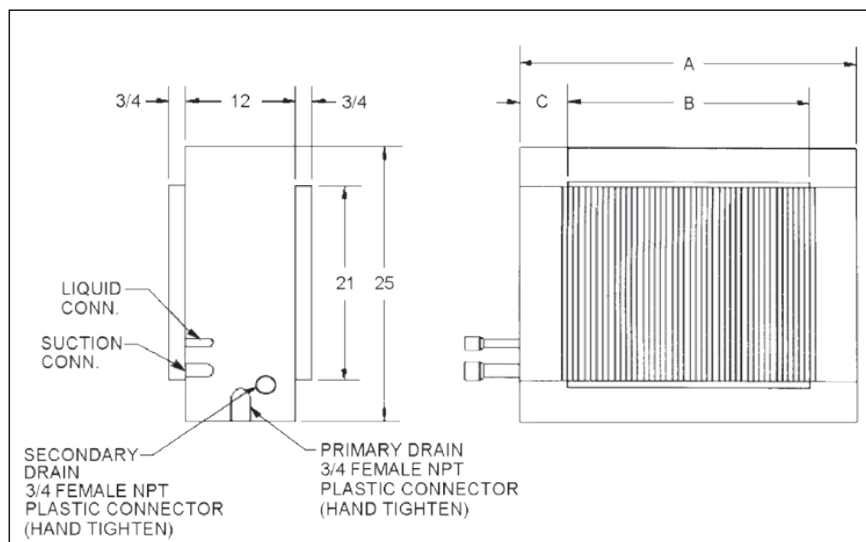

# AIRFLOW DATA FOR CAUF & CAPF

## AIR QUANTITY (SCFM) VS. PRESSURE DROP (IN. WC)

SCFM	400		500		600		700		800		900		1000		1100		1200		1300		1400		1500		1600		1700		1800		1900		2000		2100		2200						
	Wet	Dry	Wet	Dry	Wet	Dry	Wet	Dry	Wet	Dry	Wet	Dry	Wet	Dry	Wet	Dry	Wet	Dry	Wet	Dry	Wet	Dry	Wet	Dry	Wet	Dry	Wet	Dry	Wet	Dry	Wet	Dry	Wet	Dry	Wet	Dry	Wet	Dry					
CA*F1824A6*	0.071	0.062	0.099	0.090	0.142	0.122	0.183	0.154	0.230	0.189	0.280	0.231	0.331	0.278	0.389	0.331	0.390	---																									
CA*F1824B6*	0.021	0.011	0.022	0.032	0.049	0.049	0.071	0.089	0.089	0.052	0.069	0.120	0.128	0.128	0.159	0.159	0.190	0.120																									
CA*F1824C6*	0.017	0.011	0.025	0.043	0.043	0.024	0.061	0.079	0.079	0.044	0.107	0.107	0.114	0.114	0.140	0.140	0.164	0.164																									
CA*F3030A6*	0.151	0.069	0.173	0.083	0.204	0.117	0.238	0.132	0.267	0.148	0.281	0.183	0.326	0.206	0.380	0.239	0.451	0.451																									
CA*F3030B6*	0.090	0.080	0.120	0.100	0.150	0.130	0.180	0.150	0.210	0.180	0.240	0.210	0.280	0.250	0.330	0.280	0.420	0.420																									
CA*F3030C6*	0.050	0.071	0.067	0.087	0.098	0.120	0.134	0.113	0.135	0.155	0.180	0.180	0.209	0.189	0.249	0.249	0.328	0.328																									
CA*F3030D6*	0.069	0.029	0.060	0.043	0.090	0.070	0.108	0.082	0.136	0.098	0.168	0.125	0.206	0.141	0.244	0.244	0.337	0.337																									
CA*F3131B26*	0.041	0.021	0.049	0.031	0.061	0.039	0.078	0.048	0.090	0.061	0.113	0.072	0.131	0.079	0.140	0.091	0.178	0.178																									
CA*F3131C6*	0.035	0.014	0.034	0.022	0.038	0.028	0.051	0.036	0.059	0.045	0.073	0.054	0.087	0.061	0.094	0.068	0.108	0.108																									
CA*F3636A6*	0.13	0.13	0.17	0.16	0.220	0.200	0.280	0.230	0.310	0.280	0.380	0.320	0.450	0.380	0.530	0.450	0.690	0.690																									
CA*F3636B6*	0.11	0.11	0.13	0.13	0.160	0.160	0.170	0.170	0.210	0.210	0.240	0.260	0.300	0.270	0.330	0.330	0.420	0.420																									
CA*F3636C6*	0.1	0.09	0.12	0.11	0.160	0.130	0.140	0.140	0.160	0.160	0.180	0.200	0.220	0.290	0.250	0.340	0.430	0.430																									
CA*F3636D6*	0.08	0.09	0.11	0.11	0.130	0.130	0.140	0.140	0.170	0.170	0.200	0.230	0.220	0.230	0.270	0.270	0.350	0.350																									







## AIRFLOW DATA FOR CHPF

### AIR QUANTITY (SCFM) vs. PRESSURE DROP (IN. WC)

	SCFM	600	700	800	900	1000	1100	1200	1300	1400						
CHPF 1824A6*	Wet	0.132	0.179	0.222	0.272	0.327	0.381	0.456	0.522	0.605						
	Dry	0.126	0.165	0.206	0.249	0.302	0.354	0.414	0.478	0.563						
	SCFM	600	700	800	900	1000	1100	1200	1300	1400	1500	1600				
CHPF 2430B6*	Wet	0.106	0.124	0.152	0.184	0.218	0.258	0.301	0.350	0.406	0.460	0.514				
	Dry	0.101	0.122	0.145	0.174	0.209	0.247	0.288	0.333	0.381	0.428	0.484				
	SCFM	600	700	800	900	1000	1100	1200	1300	1400	1500	1600				
CHPF 3636B6*	Wet	0.107	0.131	0.167	0.199	0.239	0.291	0.338	0.389	0.439	0.494	0.552				
	Dry	0.102	0.126	0.152	0.184	0.220	0.259	0.303	0.349	0.401	0.458	0.516				
	SCFM	800	900	1000	1100	1200	1300	1400	1500	1600	1700	1800	1900	2000	2100	2200
CHPF 3642C6*	Wet	0.083	0.103	0.126	0.151	0.178	0.208	0.240	0.274	0.310	0.346	0.383	---	---	---	---
	Dry	0.073	0.096	0.120	0.144	0.169	0.196	0.224	0.254	0.286	0.319	0.354	---	---	---	---
CHPF 3642D6*	Wet	0.030	0.040	0.040	0.050	0.060	0.070	0.080	0.080	0.090	0.100	0.110	0.130	0.140	0.150	0.160
	Dry	0.040	0.050	0.060	0.070	0.080	0.080	0.090	0.100	0.110	0.120	0.120	0.120	0.150	0.160	0.180
	SCFM	800	900	1000	1100	1200	1300	1400	1500	1600	1700	1800	1900	2000	2100	2200
CHPF 3743C6*	Wet	0.133	0.153	0.176	0.201	0.228	0.258	0.290	0.324	0.360	0.396	0.433	---	---	---	---
	Dry	0.123	0.146	0.170	0.194	0.219	0.246	0.274	0.304	0.336	0.369	0.404	---	---	---	---
CHPF 3743D6*	Wet	0.101	0.105	0.115	0.125	0.145	0.165	0.185	0.215	0.235	0.265	0.295	0.315	0.355	0.375	0.405
	Dry	0.072	0.095	0.105	0.115	0.135	0.155	0.185	0.205	0.225	0.255	0.275	0.305	0.335	0.365	0.395
	SCFM	900	1000	1100	1200	1300	1400	1500	1600	1700	1800	1900	2000	2100	2200	
CHPF 4860D6*	Wet	0.101	0.121	0.131	0.161	0.181	0.201	0.231	0.261	0.291	0.321	0.361	0.391	0.431	0.471	
	Dry	0.101	0.121	0.141	0.161	0.181	0.201	0.221	0.251	0.281	0.311	0.341	0.371	0.411	0.441	

## AIRFLOW DATA FOR CSCF

### AIR QUANTITY (SCFM) vs. PRESSURE DROP (IN. WC)

	SCFM	500	600	700	800	900	1000	1100	1200										
CSCF18 24N6D*	Wet	0.104	0.143	0.176	0.212	0.255	0.292	0.321	0.344										
	Dry	0.048	0.067	0.086	0.108	0.132	0.159	0.186	0.206										
	SCFM			700	800	900	1000	1100	1200	1300	1400								
CSCF30 36N6D*	Wet			0.062	0.076	0.092	0.109	0.131	0.156	0.186	0.209								
	Dry			0.032	0.043	0.055	0.068	0.082	0.099	0.114	0.131								
	SCFM				800	900	1000	1100	1200	1300	1400	1500	1600	1700	1800	1900	2000	2100	2200
CSCF36 42N6D*	Wet				0.045	0.063	0.081	0.099	0.116	0.132	0.148	0.166	0.183	0.202	0.22	0.236	0.259	0.278	0.291
	Dry				0.039	0.051	0.064	0.077	0.092	0.105	0.121	0.138	0.15	0.175	0.191	0.214	0.23	0.251	0.262
	SCFM				800	900	1000	1100	1200	1300	1400	1500	1600	1700	1800	1900	2000	2100	2200
CSCF48 60N6D*	Wet				0.051	0.068	0.085	0.103	0.12	0.137	0.154	0.173	0.192	0.212	0.233	0.255	0.278	0.299	0.319
	Dry				0.043	0.056	0.069	0.084	0.099	0.115	0.132	0.149	0.167	0.185	0.207	0.227	0.249	0.272	.282**

\*\* Maximum SCFM = 2146

## ACCESSORIES

### EXPANSION VALVE KITS FOR NON-TXV COILS

KIT NUMBER	DESCRIPTION	APPLICATION	REFRIGERANT	TONNAGE: OUTDOOR UNIT
XVB18-36C	20% Bleed Valve	AC Only	R-22	1½ - 3 Ton
XVB42-60C	20% Bleed Valve	AC Only	R-22	3½ - 5 Ton
XV18-36C	Non-bleed Valve	AC Only	R-22	1½ - 3 Ton
XV42-60C	Non-bleed Valve	AC Only	R-22	3½ - 5 Ton
TX2N2	Non-bleed Valve	AC or HP	R-22	1½ - 2 Ton
TX3N2	Non-bleed Valve	AC or HP	R-22	2½ - 3 Ton
TX5N2	Non-bleed Valve	AC or HP	R-22	3½ - 5 Ton
TX2N4A	Non-bleed Valve	AC or HP	R-410A	1½ - 2 Ton
TX3N4	Non-bleed Valve	AC or HP	R-410A	2½ - 3 Ton
TX5N4	Non-bleed Valve	AC or HP	R-410A	3½ - 5 Ton

**Note:** Condensing units and heat pumps with reciprocating compressors require the use of start-assist components when used in conjunction with an indoor coil using a non-bleed thermal expansion valve refrigerant metering device.

### HIGH-TEMP DRAIN PAN KITS

DRAIN PAN KITS	FURNACE SIZE
HTP-A	14" furnaces
HTP-B	17½" furnaces
HTP-C	21" furnaces
HTP-D	24½" furnaces