

DAIKIN Service Instructions

DP 13 and 14 SEER PACKAGE HEAT PUMPS DP 13 and 14 PACKAGE COOLING HORIZONTAL MODELS WITH R-410A

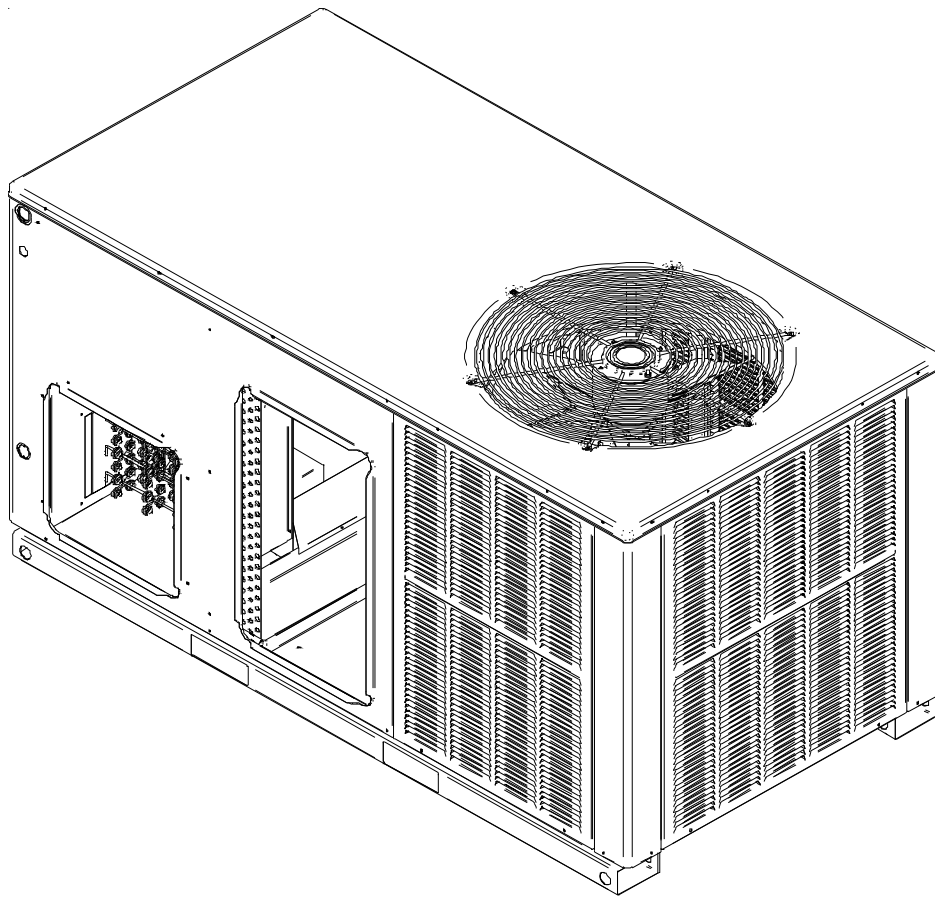

This manual is to be used by qualified, professionally trained HVAC technicians only. Daikin does not assume any responsibility for property damage or personal injury due to improper service procedures or services performed by an unqualified person.

RSD6300011r3
April 2016

INDEX

IMPORTANT INFORMATION	4 - 5
PRODUCT IDENTIFICATION - DP[13-14]C/HH**41**	6 - 7
ACCESSORIES	8
PCCP101-103 ROOF CURB	9
PCP101-103 DOWNFLOW PLENUM	9
PCEF101-103 ELBOW AND FLASHING KIT	10
DDNECNJPCHHA ECONOMIZER	10
PCMD101-103 DOWNFLOW MANUAL DAMPER	11
GPHMD101-103 HORIZONTAL MOTORIZED DAMPER WITH DUCT FLANGE	11
SQRPC SQUARE TO ROUND CONVERTER	12
SQRPCH SQUARE TO ROUND CONVERTER	12
DPHRFA EXTERNAL FILTER KIT	13
PRODUCT DESIGN	14
ELECTRICAL WIRING	15
LINE VOLTAGE WIRING	16
SYSTEM OPERATION	17
DP[13-14]C/HH**41**	
COOLING	17
COOLING CYCLE	17
HEATING CYCLE	17
DEFROST CYCLE	18
FAN OPERATION	18
SCHEDULED MAINTENANCE	21
ONCE A MONTH	21
ONCE A YEAR	21
TEST EQUIPMENT	21
SERVICING	22
COOLING/HEAT PUMP- SERVICE ANALYSIS GUIDE	22
S-1 CHECKING VOLTAGE	23
S-2 CHECKING WIRING	23
S-3 CHECKING THERMOSTAT, WIRING, AND ANTICIPATOR	23
S-3A Thermostat and Wiring	23
S-3B Cooling Anticipator	24
S-3C Heating Anticipator	24
S-4 CHECKING TRANSFORMER AND CONTROL CIRCUIT	24
S-7 CHECKING CONTACTOR AND/OR RELAYS	24
S-8 CHECKING CONTACTOR CONTACTS	25
S-9 CHECKING FAN RELAY CONTACTS	25
S-11 CHECKING LOSS OF CHARGE PROTECTOR	26
S-15 CHECKING CAPACITOR	26
S-15A RESISTANCE CHECK	27
S-15B CAPACITANCE CHECK	27
S-16 CHECKING MOTORS	28
S-16A CHECKING FAN AND BLOWER MOTOR WINDINGS (PSC MOTORS)	28
S-16D CHECKING EEM MOTORS	28
S-17 CHECKING COMPRESSOR WINDINGS	29
S-17A RESISTANCE TEST	29
S-17B GROUND TEST	29
S-17D Operation Test	30
S-18 TESTING CRANKCASE HEATER	30
S-18A CHECKING CRANKCASE HEATER THERMOSTAT	30

INDEX

S-21 CHECKING REVERSING VALVE AND SOLENOID	30
S-24 TESTING DEFROST CONTROL	31
S-25 TESTING DEFROST THERMOSTAT	31
S-50 CHECKING HEATER LIMIT CONTROL(S)	31
S-52 CHECKING HEATER ELEMENTS	31
S-100 REFRIGERATION REPAIR PRACTICE	32
S-101 LEAK TESTING	32
S-102 EVACUATION	32
S-103 CHARGING	33
S-104 CHECKING COMPRESSOR EFFICIENCY	34
S-108 SUPERHEAT	34
S-109 CHECKING SUBCOOLING	35
S-111 FIXED ORIFICE RESTRICTION DEVICES	35
S-112 CHECKING RESTRICTED LIQUID LINE	36
S-113 REFRIGERANT OVERCHARGE	36
S-114 NON-CONDENSABLES	36
S-115 COMPRESSOR BURNOUT	39
S-122 REVERSING VALVE REPLACEMENT	39
S-200 CHECKING EXTERNAL STATIC PRESSURE	40
S-201 CHECKING TEMPERATURE RISE	40
WIRING DIAGRAMS	41
OT18-60A OUTDOOR THERMOSTAT	41
OT18-60A OUTDOOR THERMOSTAT	42
SINGLE PHASE HKR** HEAT KITS	43
PCE* ECONOMIZER	44
SPK* - SINGLE POINT WIRING KIT	45
UNIT WIRING DIAGRAMS	46

IMPORTANT INFORMATION

Pride and workmanship go into every product to provide our customers with quality products. It is possible, however, that during its lifetime a product may require service. Products should be serviced only by a qualified service technician who is familiar with the safety procedures required in the repair and who is equipped with the proper tools, parts, testing instruments and the appropriate service manual. **REVIEW ALL SERVICE INFORMATION IN THE APPROPRIATE SERVICE MANUAL BEFORE BEGINNING REPAIRS.**

IMPORTANT NOTICES FOR CONSUMERS AND SERVICERS RECOGNIZE SAFETY SYMBOLS, WORDS AND LABELS

WARNING

This unit should not be connected to, or used in conjunction with, any devices that are not design certified for use with this unit or have not been tested and approved by Daikin. Serious property damage or personal injury, reduced unit performance and/or hazardous conditions may result from use of devices that have not been approved or certified by Daikin.

WARNING

ONLY PERSONNEL THAT HAVE BEEN TRAINED TO INSTALL, ADJUST, SERVICE OR REPAIR (HEREINAFTER, "SERVICE") THE EQUIPMENT SPECIFIED IN THIS MANUAL SHOULD SERVICE THE EQUIPMENT. THE MANUFACTURER WILL NOT BE RESPONSIBLE FOR ANY INJURY OR PROPERTY DAMAGE ARISING FROM IMPROPER SERVICE OR SERVICE PROCEDURES. IF YOU SERVICE THIS UNIT, YOU ASSUME RESPONSIBILITY FOR ANY INJURY OR PROPERTY DAMAGE WHICH MAY RESULT. IN ADDITION, IN JURISDICTIONS THAT REQUIRE ONE OR MORE LICENSES TO SERVICE THE EQUIPMENT SPECIFIED IN THIS MANUAL, ONLY LICENSED PERSONNEL SHOULD SERVICE THE EQUIPMENT. IMPROPER INSTALLATION, ADJUSTMENT, SERVICING OR REPAIR OF THE EQUIPMENT SPECIFIED IN THIS MANUAL, OR ATTEMPTING TO INSTALL, ADJUST, SERVICE OR REPAIR THE EQUIPMENT SPECIFIED IN THIS MANUAL WITHOUT PROPER TRAINING MAY RESULT IN PRODUCT DAMAGE, PROPERTY DAMAGE, PERSONAL INJURY OR DEATH.

WARNING

TO PREVENT THE RISK OF PROPERTY DAMAGE, PERSONAL INJURY, OR DEATH, DO NOT STORE COMBUSTIBLE MATERIALS OR USE GASOLINE OR OTHER FLAMMABLE LIQUIDS OR VAPORS IN THE VICINITY OF THIS APPLIANCE.

WARNING

HIGH VOLTAGE

DISCONNECT ALL POWER BEFORE SERVICING OR INSTALLING THIS UNIT. MULTIPLE POWER SOURCES MAY BE PRESENT. FAILURE TO DO SO MAY CAUSE PROPERTY DAMAGE, PERSONAL INJURY OR DEATH.



To locate an authorized servicer, please consult your telephone book or the dealer from whom you purchased this product. For further assistance, please contact:

CONSUMER INFORMATION LINE - DAIKIN BRAND PRODUCTS

TOLL FREE 1-855-770-5648 (U.S. only)

email us at: customerservice@daikincomfort.com

fax us at: **(713) 856-1821**

(Not a technical assistance line for dealers.)

Outside the U.S., call **1-713-861-2500**

(Not a technical assistance line for dealers.)

Your telephone company will bill you for the call.

IMPORTANT INFORMATION

SAFE REFRIGERANT HANDLING

While these items will not cover every conceivable situation, they should serve as a useful guide.

WARNING

REFRIGERANTS ARE HEAVIER THAN AIR. THEY CAN "PUSH OUT" THE OXYGEN IN YOUR LUNGS OR IN ANY ENCLOSED SPACE. TO AVOID POSSIBLE DIFFICULTY IN BREATHING OR DEATH:

- NEVER PURGE REFRIGERANT INTO AN ENCLOSED ROOM OR SPACE. BY LAW, ALL REFRIGERANTS MUST BE RECLAIMED.
- IF AN INDOOR LEAK IS SUSPECTED, THOROUGHLY VENTILATE THE AREA BEFORE BEGINNING WORK.
- LIQUID REFRIGERANT CAN BE VERY COLD. TO AVOID POSSIBLE FROST-BITE OR BLINDNESS, AVOID CONTACT WITH REFRIGERANT AND WEAR GLOVES AND GOGGLES. IF LIQUID REFRIGERANT DOES CONTACT YOUR SKIN OR EYES, SEEK MEDICAL HELP IMMEDIATELY.
- ALWAYS FOLLOW EPA REGULATIONS. NEVER BURN REFRIGERANT, AS POISONOUS GAS WILL BE PRODUCED.

WARNING

THE UNITED STATES ENVIRONMENTAL PROTECTION AGENCY ("EPA") HAS ISSUED VARIOUS REGULATIONS REGARDING THE INTRODUCTION AND DISPOSAL OF REFRIGERANTS INTRODUCED INTO THIS UNIT. FAILURE TO FOLLOW THESE REGULATIONS MAY HARM THE ENVIRONMENT AND CAN LEAD TO THE IMPOSITION OF SUBSTANTIAL FINES. THESE REGULATIONS MAY VARY BY JURISDICTION. A CERTIFIED TECHNICIAN MUST PERFORM THE INSTALLATION AND SERVICE OF THIS PRODUCT. SHOULD QUESTIONS ARISE, CONTACT YOUR LOCAL EPA OFFICE. VIOLATIONS OF EPA REGULATIONS MAY RESULT IN FINES OR PENALTIES.

WARNING

SYSTEM CONTAMINANTS, IMPROPER SERVICE PROCEDURE AND/OR PHYSICAL ABUSE AFFECTING HERMETIC COMPRESSOR ELECTRICAL TERMINALS MAY CAUSE DANGEROUS SYSTEM VENTING.

The successful development of hermetically sealed refrigeration compressors has completely sealed the compressor's moving parts and electric motor inside a common housing, minimizing refrigerant leaks and the hazards sometimes associated with moving belts, pulleys or couplings.

Fundamental to the design of hermetic compressors is a method whereby electrical current is transmitted to the compressor motor through terminal conductors which pass through the compressor housing wall. These terminals are sealed in a dielectric material which insulates them from the housing and maintains the pressure tight integrity of the hermetic compressor. The terminals and their dielectric embedment are strongly constructed, but are vulnerable to careless compressor installation or maintenance procedures and equally vulnerable to internal electrical short circuits caused by excessive system contaminants.

WARNING

TO AVOID POSSIBLE EXPLOSION:

- NEVER APPLY FLAME OR STEAM TO A REFRIGERANT CYLINDER. IF YOU MUST HEAT A CYLINDER FOR FASTER CHARGING, PARTIALLY IMMERSE IT IN WARM WATER.
- NEVER FILL A CYLINDER MORE THAN 80% FULL OF LIQUID REFRIGERANT.
- NEVER ADD ANYTHING OTHER THAN R-22 TO AN R-22 CYLINDER OR R-410A TO AN R-410A CYLINDER. THE SERVICE EQUIPMENT USED MUST BE LISTED OR CERTIFIED FOR THE TYPE OF REFRIGERANT USED.
- STORE CYLINDERS IN A COOL, DRY PLACE. NEVER USE A CYLINDER AS A PLATFORM OR A ROLLER.

WARNING

TO AVOID POSSIBLE EXPLOSION, USE ONLY RETURNABLE (NOT DISPOSABLE) SERVICE CYLINDERS WHEN REMOVING REFRIGERANT FROM A SYSTEM.

- ENSURE THE CYLINDER IS FREE OF DAMAGE WHICH COULD LEAD TO A LEAK OR EXPLOSION.
- ENSURE THE HYDROSTATIC TEST DATE DOES NOT EXCEED 5 YEARS.
- ENSURE THE PRESSURE RATING MEETS OR EXCEEDS 400 LBS.

WHEN IN DOUBT, DO NOT USE CYLINDER.

WARNING

TO AVOID POSSIBLE INJURY, EXPLOSION OR DEATH, PRACTICE SAFE HANDLING OF REFRIGERANTS.

In either of these instances, an electrical short between the terminal and the compressor housing may result in the loss of integrity between the terminal and its dielectric embedment. This loss may cause the terminals to be expelled, thereby venting the vaporous and liquid contents of the compressor housing and system.

A venting compressor terminal normally presents no danger to anyone, providing the terminal protective cover is properly in place.

If, however, the terminal protective cover is not properly in place, a venting terminal may discharge a combination of

- hot lubricating oil and refrigerant
- flammable mixture (if system is contaminated with air)

in a stream of spray which may be dangerous to anyone in the vicinity. Death or serious bodily injury could occur.

Under no circumstances is a hermetic compressor to be electrically energized and/or operated without having the terminal protective cover properly in place.

See Service Section S-17 for proper servicing.

PRODUCT IDENTIFICATION

The model number is used for positive identification of component parts used in manufacturing. Please use this number when requesting service or parts information.

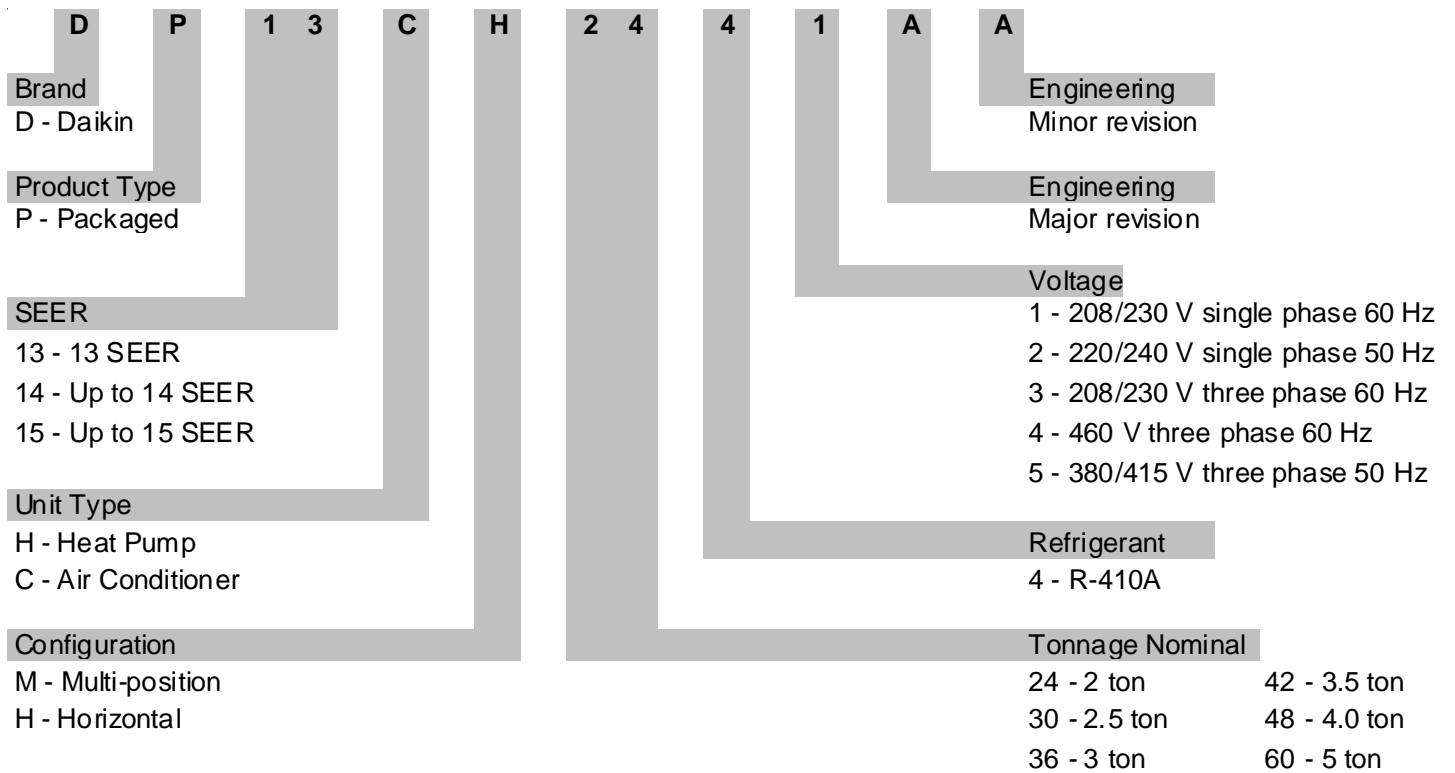

PRODUCT IDENTIFICATION

Model #	Package Cooling Description
DP13CH[24-60]41**	<u>D</u> aikin <u>P</u> ackage <u>C</u> ooling up to 13 Seer R410A <u>H</u> orizontal electric cooling unit. Initial release of 208-230/1/60 single phase models.
DP14CH[24-60]41**	<u>D</u> aikin <u>P</u> ackage <u>C</u> ooling up to 14 Seer R410A <u>H</u> orizontal electric cooling unit. Initial release of 208-230/1/60 single phase models.
DP14CH24-3041BB DP14CH3641AC DP14CH42-6041BB	<u>D</u> aikin <u>P</u> ackage <u>C</u> ooling up to 14 Seer R410A <u>H</u> orizontal electric cooling unit, 208-230/1/60 single phase models. Converted Aluminum coils with 3/8" return bends/crossovers to Aluminum coils using 9mm return bends/crossovers.
DP14CH24-3041BC DP14CH3641AD DP14CH42-6041BC	<u>D</u> aikin <u>P</u> ackage <u>C</u> ooling up to 14 Seer R410A <u>H</u> orizontal electric cooling unit, 208-230/1/60 single phase models. Release of models with access box removed.

Model #	Package Heat Pump Description
DP13HH[24-60]41**	<u>D</u> aikin <u>P</u> ackage <u>H</u> eat Pump up to 13 Seer R410A <u>H</u> orizontal heat pump unit. Initial release of 208-230/1/60 single phase models.
DP14HH[24-60]41**	<u>D</u> aikin <u>P</u> ackage <u>H</u> eat Pump up to 14 Seer R410A <u>H</u> orizontal heat pump unit. Initial release of 208-230/1/60 single phase models.
DP14HH24-3641AC DP14HH42-6041BB	<u>D</u> aikin <u>P</u> ackage <u>H</u> eat Pump up to 14 Seer R410A <u>H</u> orizontal heat pump unit, 208-230/1/60 single phase models. Converted Aluminum coils with 3/8" return bends/crossovers to Aluminum coils using 9mm return bends/crossovers.
DP14HH24-3641AD DP14HH42-6041BC	<u>D</u> aikin <u>P</u> ackage <u>H</u> eat Pump up to 14 Seer R410A <u>H</u> orizontal heat pump unit, 208-230/1/60 single phase models. Release of models with access box removed.
DP14HH6041CA	<u>D</u> aikin <u>P</u> ackage <u>H</u> eat Pump up to 14 Seer R410A <u>H</u> orizontal heat pump unit, 208-230/1/60 single phase models. - Develop and release 14 SEER 5 Ton H model heat pump with new 7 mm condenser coil.

ACCESSORIES - DP**C/DP**H**** MODELS	
Part Number	Description
PCCP101-103	14" Roof Curb for Daikin H- Series Package Unit All Chassis Requires PCP101-103
PCP101-103	Downflow Plenum Kit for Daikin H- Series Package Units All Chassis. Requires PCCP101-103
PCP101-103R8	Downflow Plenum Kit for Daikin H- Series Package Units w/ R-8 Insulation Liner All Chassis. Requires PCCP101-103
PCMD101-103	Manual Damper for Daikin H-Series Package Units. Requires PCP101-103
PCMDM101-103	Motorized Damper for Daikin H- Series Package Units. Requires PCP101-103
GPHMD101-103	Horizontal Manual Damper for Daikin H- Series Package Unit Horizontal Applications All Chassis
SQRPCH101	Horizontal Square to Round Adapters for H- Series Package Unit 16"&14" Round.
SQRPCH102-103	Horizontal Square to Round Adapters for H- Series Package Unit 18"&14"
SQRPC101	Downflow Square to Round Adapter for H- Series Package Unit 16" Rounds. Requires PCCP101-103 and PCP101-103
SQRPC102-103	Downflow Square to Round Adapter for H- Series Package Unit 18" Rounds. Requires PCCP101-103 and PCP101-103
DPHFRA	External Horizontal Filter Rack for Daikin M- and H- Series Package Units
PCEF101-103	Elbow & Flashing w/ R-8 Liner for Daikin H- Series Package Unit All Chassis
CDK36	3 Ton Concentric Duct Kit
CDK36515	3 Ton Flush Mount Concentric Duct Kit w/ Filter
CDK36530	3 Ton Step Down Concentric Duct Kit
CDK36535	3 Ton Step Down Concentric Duct Kit w/ Filter
CDK4872	4 - 6 Ton Concentric Duct Kit
CDK4872515	4 - 6 Ton Flush Mount Concentric Duct Kit w/ Filter
CDK4872530	4 - 6 Ton Step Down Concentric Duct Kit
CDK4872535	4 - 6 Ton Step Down Concentric Duct Kit w/ Filter
DDNECNJPCHHA	Downflow Economizer H-Series Package Unit. Requires PCP101-103.
DHZECNJPGCHM	Economizer H-Series Daikin Package Unit

THERMOSTATS			
CH70TG	Manual Changeover	Digital, Nonprogrammable	1 Heat - 1 Cool
CHSATG	Manual Changeover	Mechanical, Nonprogrammable	1 Heat - 1 Cool
CHT18-60	Manual Changeover	Mechanical, Nonprogrammable	1 Heat - 1 Cool
CHT90-120	Manual Changeover	Mechanical, Nonprogrammable	2 Heat - 2 Cool
CHTP18-60HD	Manual Changeover	Digital, Nonprogrammable	2 Heat - 1 Cool
CT18-60	Manual Changeover	Mechanical, Nonprogrammable	Cool Only

THERMOSTATS				
1213401	White	Manual Changeover	5 + 2 Programming Digital	1 Heat - 1 Cool
1213402	White	Manual Changeover	Nonprogrammable Digital	1 Heat - 1 Cool
1213403	White	Manual Changeover	7 Day Programming Digital	2 Heat - 1 Cool
1213404	White	Manual Changeover	Nonprogrammable Digital	2 Heat - 1 Cool
1213406	Beige	Manual/Auto Changeover	5 + 2 Programming Digital	3 Heat - 2 Cool
1213407	White	Manual Changeover	5 + 2 Programming Digital	2 Heat - 2 Cool
1213408	White	Manual/Auto Changeover	7 Day Programming Digital	1 Heat - 1 Cool
1213410	White	Manual Changeover	5 + 2 Programming Digital	2 Heat - 1 Cool
1213411	White	Manual Changeover	Nonprogrammable Digital	2 Heat - 2 Cool
1213412	White	Manual/Auto Changeover	7 Day Programming Digital	3 Heat - 2 Cool
1213431	White	Manual/Auto Changeover	7 Day Programming Digital	3 Heat - 2 Cool

PCCP101-103 ROOF CURB

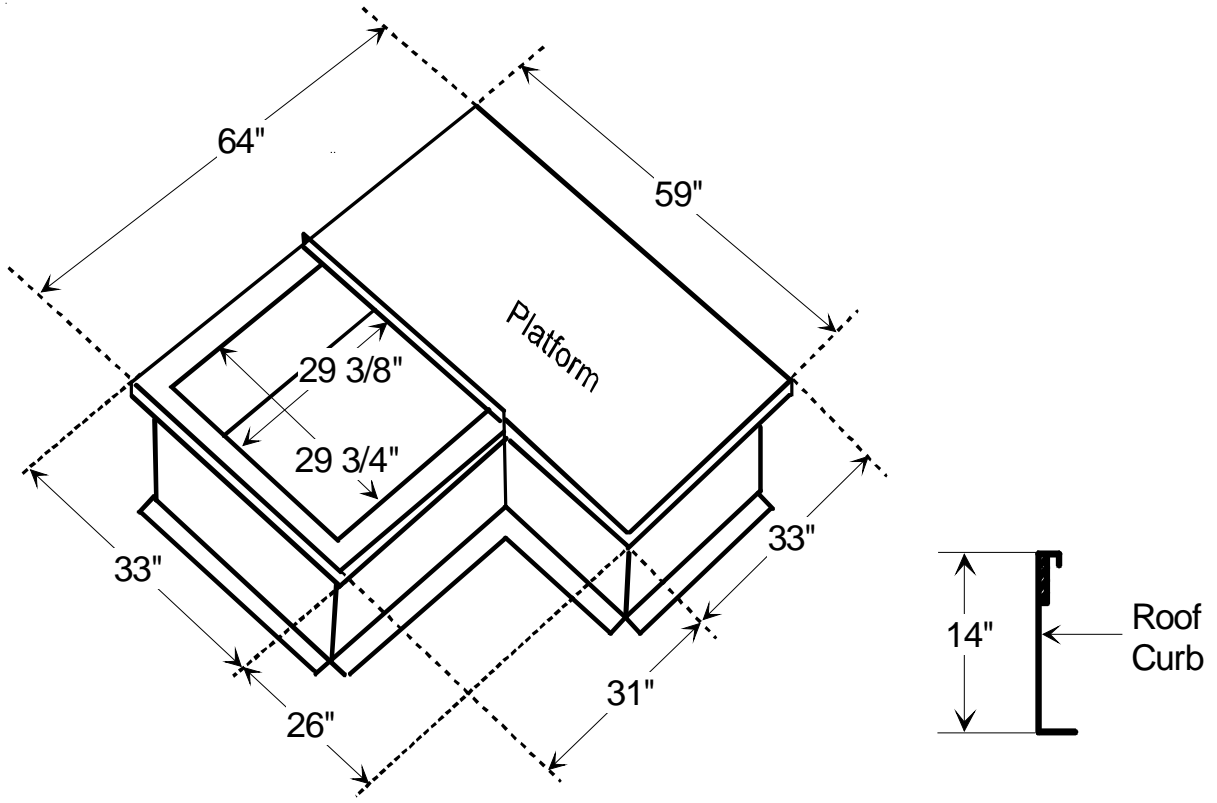

PCP101-103 DOWNFLOW PLENUM

(Use with PCCP Roof Curb)

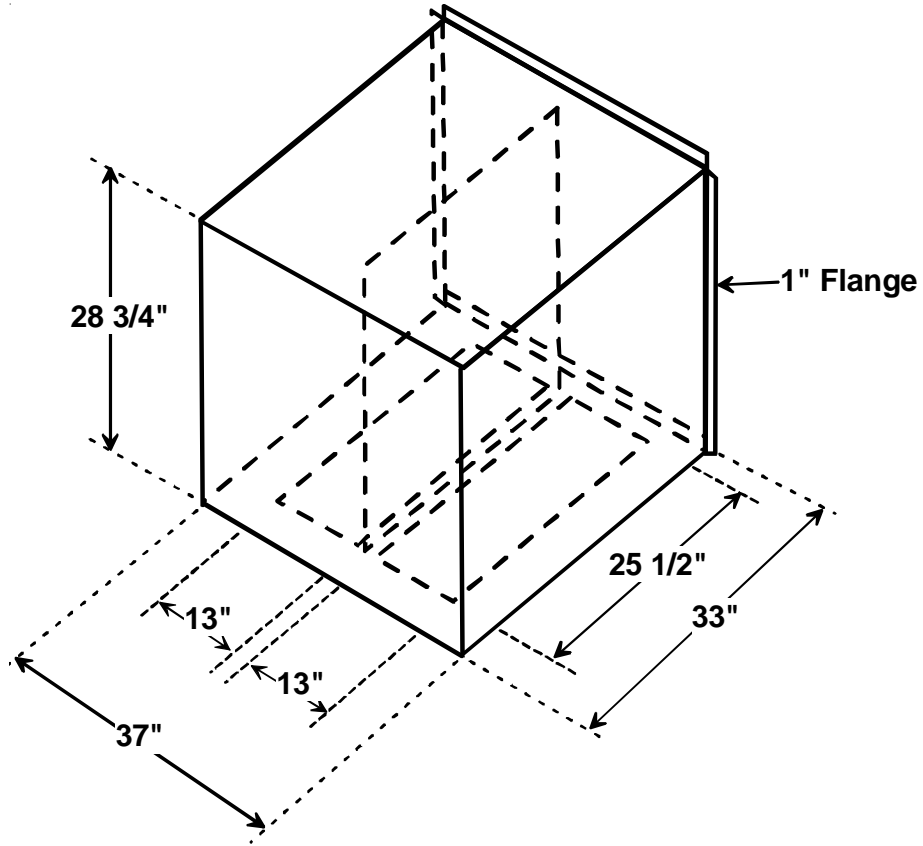

PCEF101-103 ELBOW AND FLASHING KIT

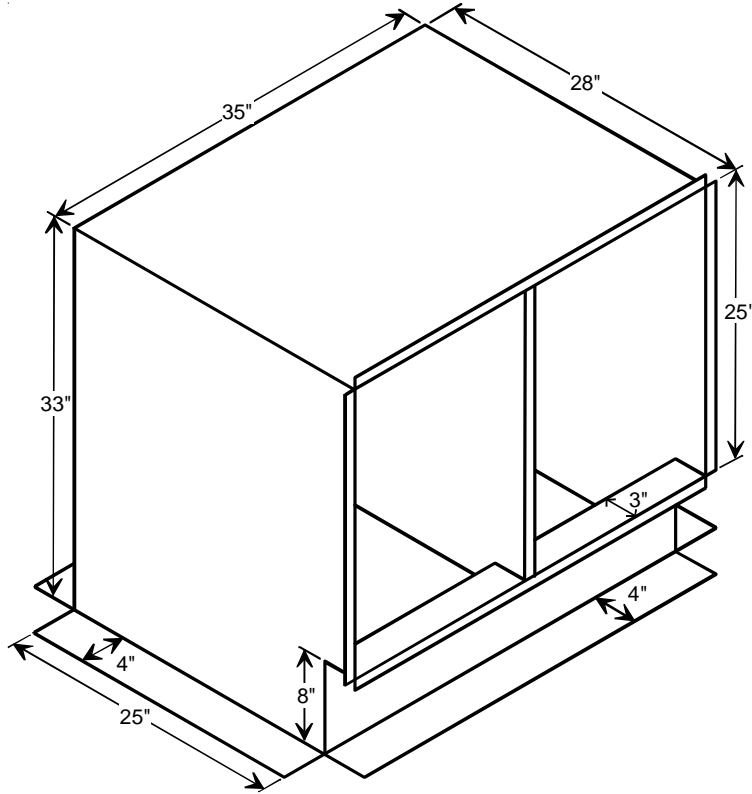

**DDNECNJPCHHA ECONOMIZER*
(DOWNFLOW APPLICATIONS)**

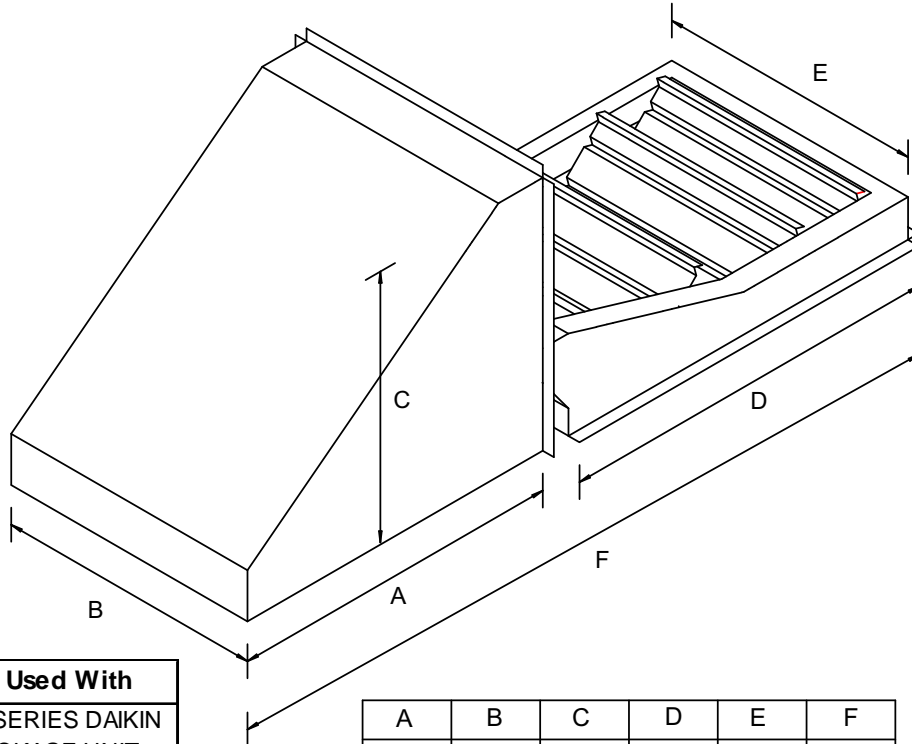

Model	Used With
DDNECNJPCHHA	H-SERIES DAIKIN PACKAGE UNIT. REQUIRES PCP101-103

A	B	C	D	E	F
20	16.25	16	23.5	12.5	45.75

ACCESSORIES

DP[13-14]CH/HH41A***

DHZECNJP GCHM ECONOMIZER*

(HORIZONTAL APPLICATIONS)

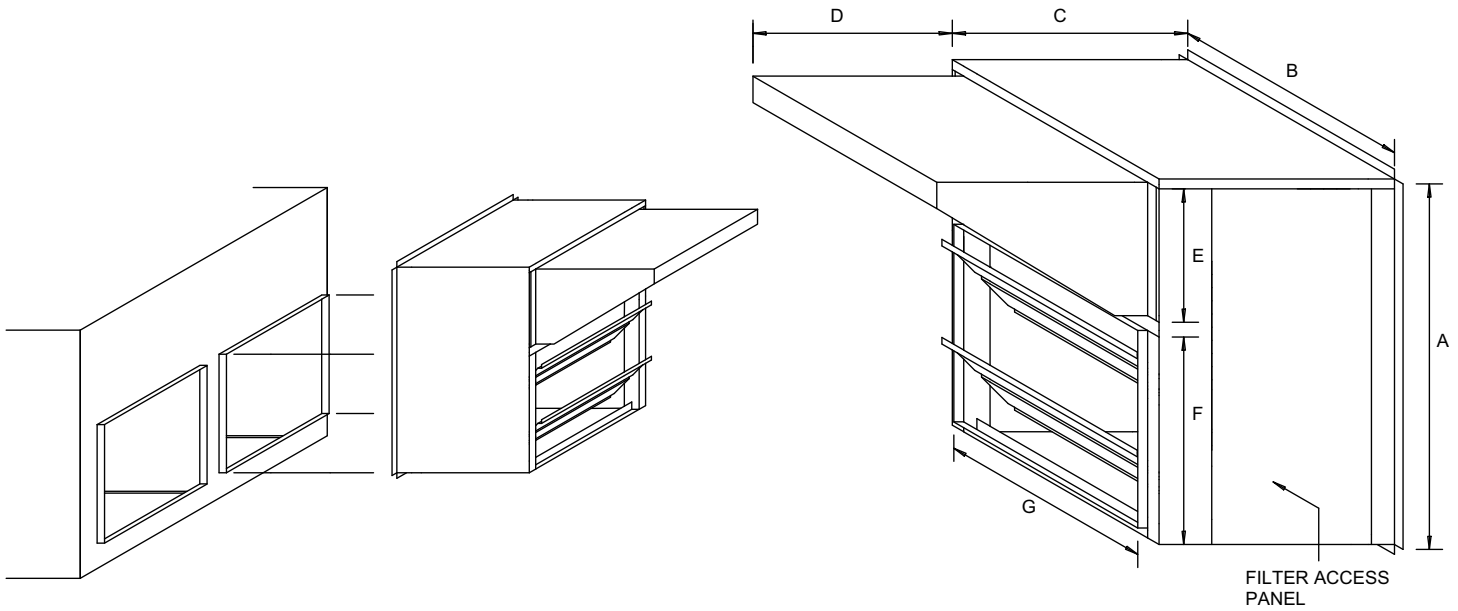

Shipped with 16 x 25 x 1" Filter and 14.5 x 15.5 Mist Eliminator Installed

ECONOMIZER	A	B	C	D	E	F	G
DHZECNJP GCHM	25.25	18.125	18	16	10.375	13.75	16.125

PCMD101-103 DOWNFLOW MANUAL DAMPER*

PCMDM101-103 DOWNFLOW MOTORIZED DAMPER*

**USED WITH PCP101-103 DOWNFLOW PLENUM*

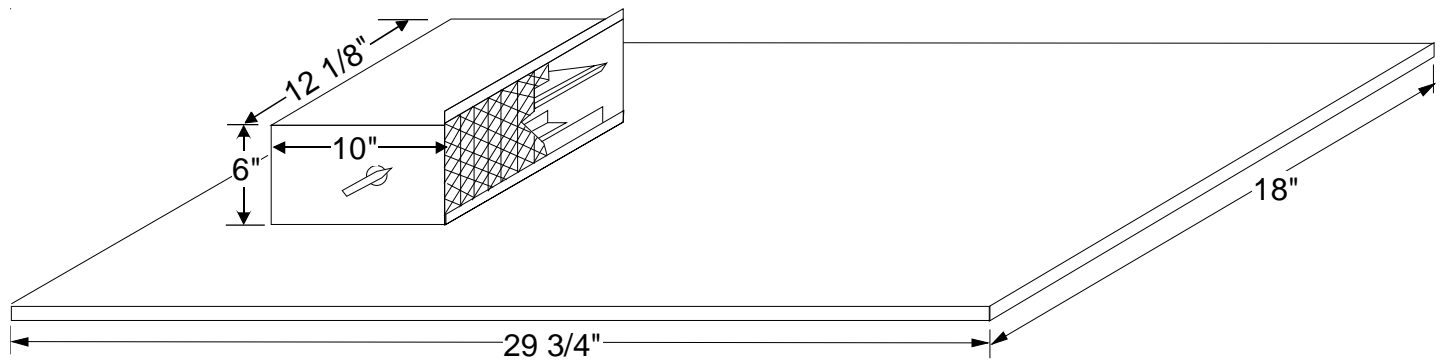

MODEL	DESCRIPTION
PCMDH101-103	Manual Damper
PCMDM101-103	Motorized Damper

ACCESSORIES

DP[13-14]CH/HH**41A*

GPHMD101-103 HORIZONTAL MANUAL DAMPER WITH DUCT FLANGE

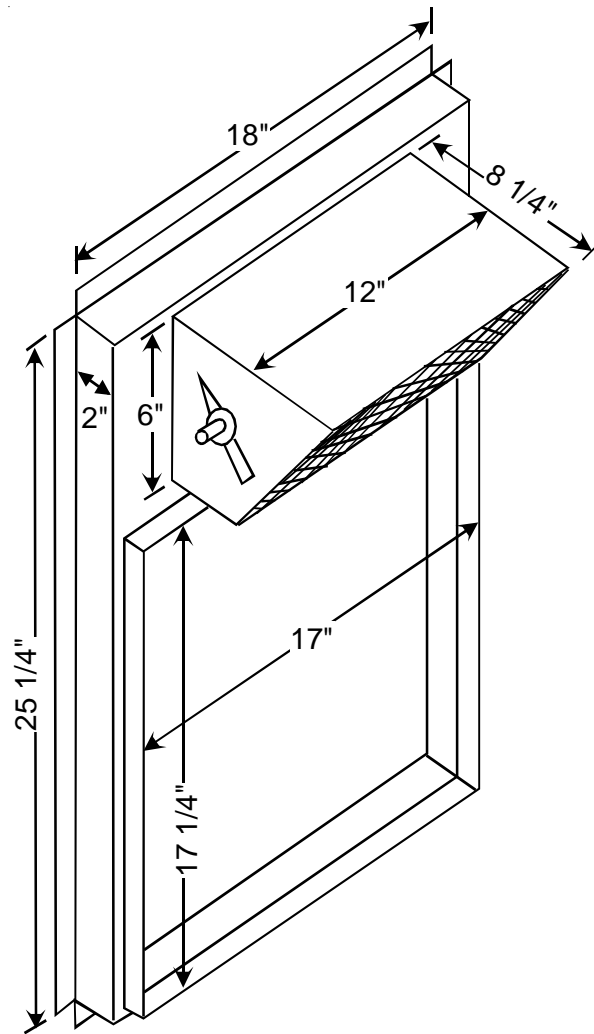

SQRPC SQUARE TO ROUND CONVERTER
(DOWNFLOW APPLICATIONS)

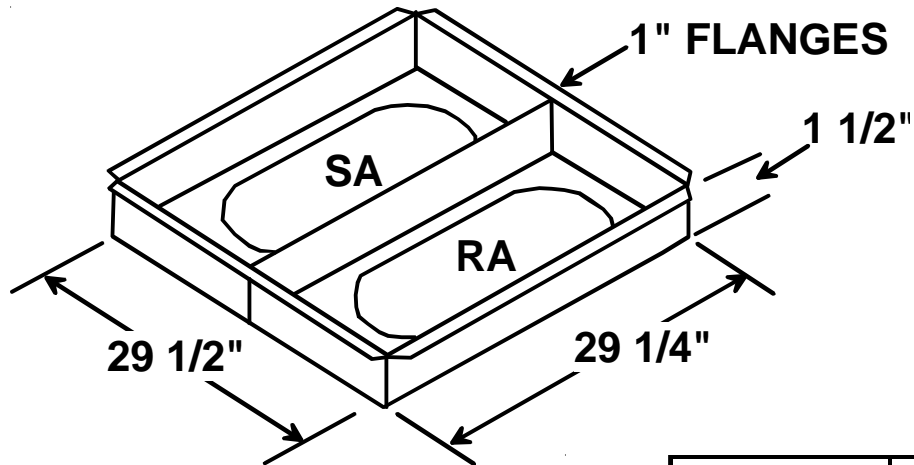

	SQRPC101	SQRP102-103
SA	16"	18"
RA	16"	18"

ACCESSORIES

DP[13-14]CH/HH**41A*

SQRPCH SQUARE TO ROUND CONVERTER (HORIZONTAL APPLICATIONS)

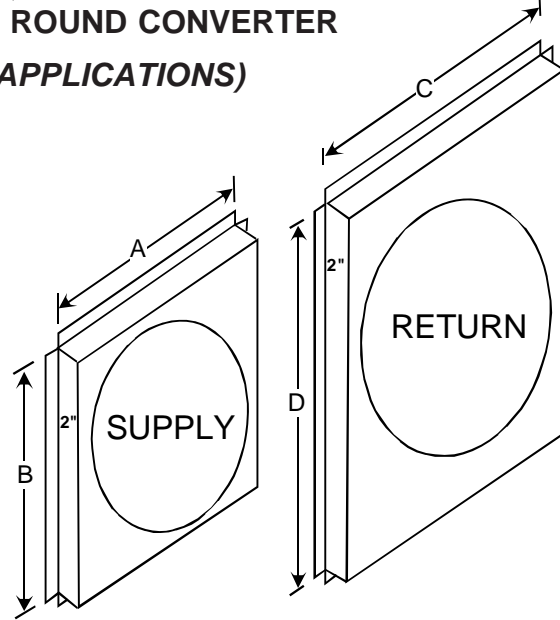
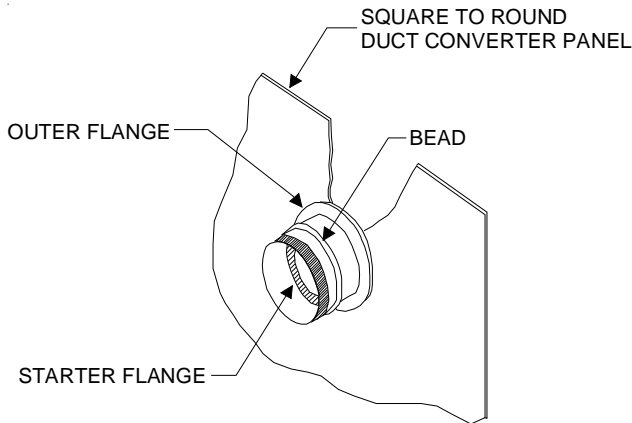

	SQRPCH-101	SQRPCH-102	SQRPCH-103	SQRPCH102-14	SQRPCH103-14
A	15"	17"	17"	15"	15"
B	15"	17"	17"	15"	15"
C	17"	17"	19"	15"	15"
D	22 1/2"	24 1/2"	24 1/2"	24 1/2"	24 1/2"
SUPPLY	14"	16"	16"	14"	14"
RETURN	16"	16"	18"	14"	14"

DPHFRA EXTERNAL FILTER KIT (HORIZONTAL APPLICATIONS)

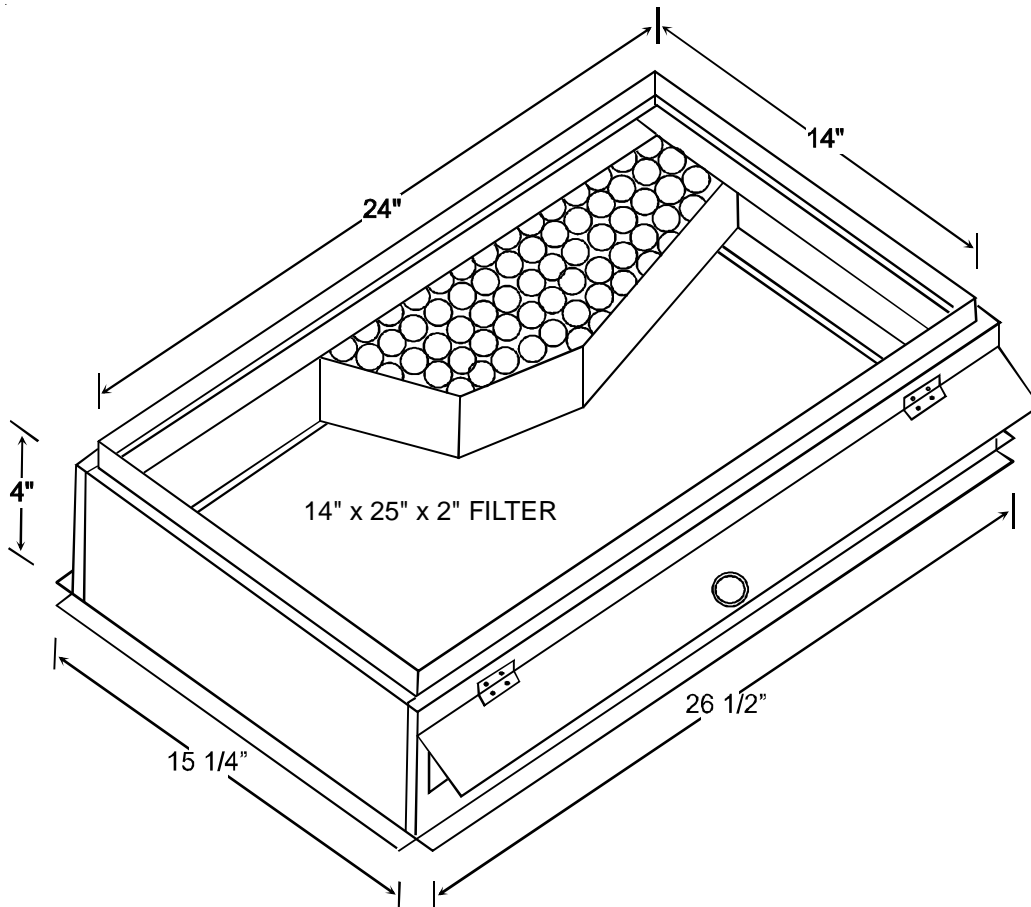

PRODUCT DESIGN

LOCATION & CLEARANCES

NOTE: To ensure proper condensate drainage, unit must be installed in a level position.

In installations where the unit is installed above ground level and not serviceable from the ground (Example: Roof Top installations) the installer must provide a service platform for the service person with rails or guards in accordance with local codes or ordinances.

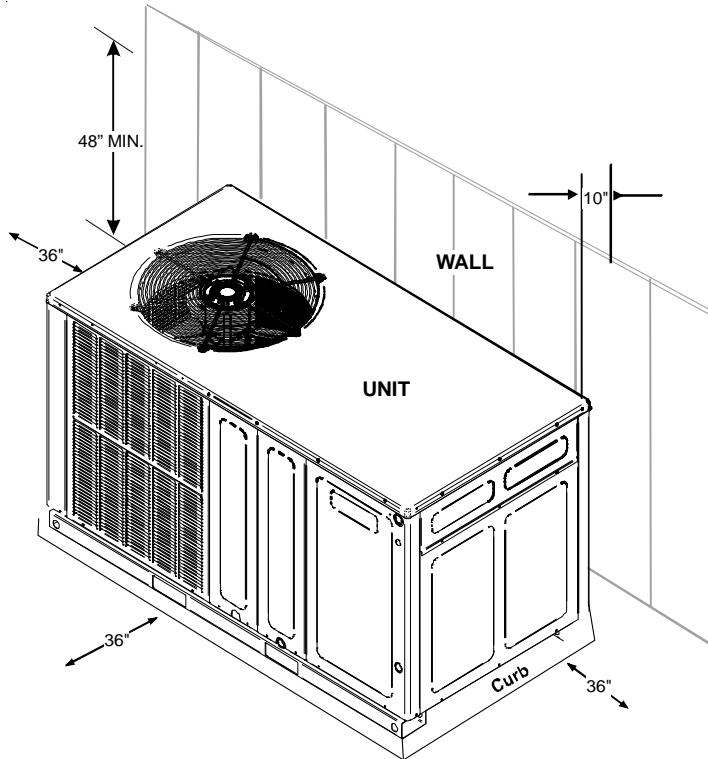

DP[13-14]CH/DP[13-14]HH**41*

NOTE: Roof overhang should be no more than 36" and provisions made to deflect the warm discharge air out from the overhang.

Minimum clearances are required to avoid air recirculation and keep the unit operating at peak efficiency.

⚠ WARNING

TO PREVENT POSSIBLE DAMAGE, THE UNIT SHOULD REMAIN IN AN UPRIGHT POSITION DURING ALL RIGGING AND MOVING OPERATIONS. TO FACILITATE LIFTING AND MOVING IF A CRANE IS USED, PLACE THE UNIT IN AN ADEQUATE CABLE SLIDE.

Refer to Roof Curb Installation Instructions for proper curb installation. Curbing must be installed in compliance with the National Roofing Contractors Association Manual.

Lower unit carefully onto roof mounting curb. While rigging unit, center of gravity will cause condenser end to be lower than supply air end.

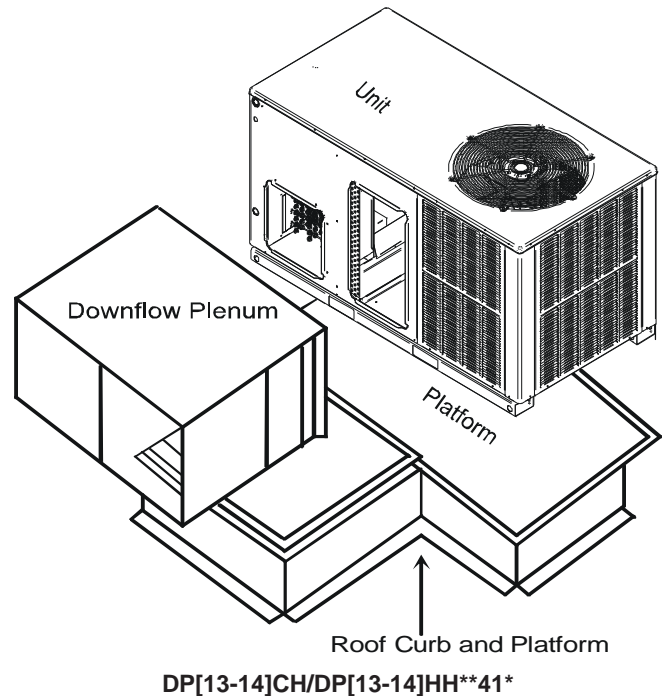

DPCH/DPHH Package Units are designed for outdoor installations only in either residential or light commercial applications.

NOTE: To ensure proper condensate drainage, unit must be installed in a level position.

The connecting ductwork (Supply and Return) can be connected for horizontal discharge airflow. In the down discharge applications, a matching Platform/Roof Curb (PCCP) and Downflow Plenum (PCP101-103) is recommended for horizontal models only.

A return air filter must be installed behind the return air grille(s) or provision must be made for a filter in an accessible location within the return air duct. The minimum filter area should not be less than those sizes listed in the Specification Section. Under no circumstances should the unit be operated without return air filters.

A 3/4" - 14 NPT drain connector is provided for removal of condensate water from the indoor coil. In order to provide proper condensate flow, do not reduce the drain line size.

Refrigerant flow control is achieved by use of restrictor orifices. These models use the FasTest Access Fitting System, with a saddle that is either soldered to the suction and liquid lines or is fastened with a locking nut to the access fitting box (core) and then screwed into the saddle. **Do not remove the core from the saddle until the refrigerant charge has been removed. Failure to do so could result in property damage or personal injury.**

The single phase units use permanent split capacitors (PSC) design compressors. Starting components are therefore not required. A low MFD run capacitor assists the compressor to start and remains in the circuit during operation.

The outdoor fan motors are single phase capacitor type motors.

PRODUCT DESIGN

Air for condensing (cooling) is drawn through the outdoor coil by a propeller fan, and is discharged vertically out the top of the unit. The outdoor coil is designed for .0 static. No additional restriction (ductwork) shall be applied.

Conditioned air is drawn through the filter(s), field installed, across the evaporator coil and back into the conditioned space by the indoor blower.

COMPRESSORS

Some DPCH/DPHH series package units use the Compliant Scroll compressor, instead of traditional reciprocating compressors. Still other models use reciprocating compressors.

A scroll is an involute spiral which, when matched with a mating scroll form as shown, generates a series of crescent shaped gas pockets between the two members.

During compression, one scroll remains stationary (fixed scroll) while the other form (orbiting scroll) is allowed to orbit (but not rotate) around the first form.

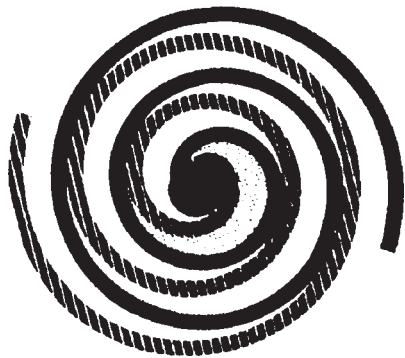

As this motion occurs, the pockets between the two forms are slowly pushed to the center of the two scrolls while simultaneously being reduced in volume. When the pocket reaches the center of the scroll form, the gas, which is now at a high pressure, is discharged out of a port located at the center.

During compression, several pockets are being compressed simultaneously, resulting in a very smooth process. Both the suction process (outer portion of the scroll members) and the discharge process (inner portion) are continuous.

Some design characteristics of the Compliant Scroll compressor are:

- Compliant Scroll compressors are more tolerant of liquid refrigerant.
NOTE: Even though the compressor section of a Scroll compressor is more tolerant of liquid refrigerant, continued floodback or flooded start conditions may wash oil from the bearing surfaces causing premature bearing failure.
- Compliant Scroll compressors use "POE" or polyolester oil, which is NOT compatible with mineral oil based lubricant like 3GS. "POE" oil must be used if additional oil is required.
- Compliant scroll compressors perform "quiet" shutdowns that allow the compressor to restart immediately without the need for a time delay. This compressor will restart even if the system has not equalized.

NOTE: Operating pressures and amp draws may differ from standard reciprocating compressors. This information can be found in the unit's Technical Information Manual.

INDOOR BLOWER MOTOR

Some DPCH/DPHH model package units use a EEM blower motor while others use the standard PSC type blower motor. The EEM motor is a 3 Phase brushless DC (single phase AC input), ball bearing construction motor with an integral control module with an internal FCC B EMI filter.

The EEM motor is continuously powered with line voltage. The switched 24 volt control signal is controlled by the thermostat in the cooling and heat pump mode and the blower relay in the electric heat mode.

ELECTRICAL WIRING

The units are designed for operation at the voltages and hertz as shown on the rating plate. All internal wiring is complete. Ensure the power supply to the compressor contactor is brought to the unit as shown on the supplied unit wiring diagram. The 24V wiring must be connected between the unit control panel and the room thermostat.

WARNING

TO AVOID PERSONAL INJURY OR DEATH DUE TO ELECTRIC SHOCK, WIRING TO THE UNIT MUST BE PROPERLY POLARIZED AND GROUNDED.

WARNING

**HIGH VOLTAGE!
DISCONNECT ALL POWER BEFORE
CHANGING ANY ELECTRICAL WIRING.
MULTIPLE POWER SOURCES MAY BE
PRESENT. FAILURE TO DO SO MAY CAUSE PROPERTY
DAMAGE, PERSONAL INJURY OR DEATH.**



WARNING

**TO AVOID THE RISK OF PROPERTY DAMAGE,
PERSONAL INJURY OR FIRE, USE ONLY COPPER
CONDUCTORS.**

PRODUCT DESIGN

LINE VOLTAGE WIRING

Power supply to the unit must be N.E.C. Class 1, and must comply with all applicable codes. The unit must be electrically grounded in accordance with the local codes or, in their absence, with the latest edition of the National Electrical Code, ANSI/NFPA No. 70, or in Canada, Canadian Electrical Code, C22.1, Part 1. A fused disconnect must be provided and sized in accordance with the unit minimum circuit ampacity.

The best protection for the wiring is the smallest fuse or breaker which will hold the equipment on line during normal operation without nuisance trips. Such a device will provide maximum circuit protection.



All line voltage connections must be made through weather proof fittings. All exterior power supply and ground wiring must be in approved weather proof conduit. Low voltage wiring from the unit control panel to the thermostat requires coded cable.

The unit transformer is connected for 230V operation. If the unit is to operate on 208V, reconnect the transformer primary lead as shown on the unit wiring diagram.

If it is necessary for the installer to supply additional line voltage wiring to the inside of the package unit, the wiring must comply with all local codes. This wiring must have a minimum temperature rating of 105°C. All line voltage splices must be made inside the unit or heat kit control box.

SYSTEM OPERATION

COOLING

The refrigerant used in the system is R-410A. It is a clear, colorless, non-toxic and non-irritating liquid. R-410A is a 50:50 blend of R-32 and R-125. The boiling point at atmospheric pressure is **-62.9°F**.

A few of the important principles that make the refrigeration cycle possible are: heat always flows from a warmer to a cooler body. Under lower pressure, a refrigerant will absorb heat and vaporize at a low temperature. The vapors may be drawn off and condensed at a higher pressure and temperature to be used again.

The indoor evaporator coil functions to cool and dehumidify the air conditioned spaces through the evaporative process taking place within the coil tubes.

Heat is continually being transferred to the cool fins and tubes of the indoor evaporator coil by the warm system air. This warming process causes the refrigerant to boil. The heat removed from the air is carried off by the vapor.

As the vapor passes through the last tubes of the coil, it becomes superheated. That is, it absorbs more heat than is necessary to vaporize it. This is assurance that only dry gas will reach the compressor. Liquid reaching the compressor can weaken or break compressor valves.

The compressor increases the pressure of the gas, thus adding more heat, and discharges hot, high pressure superheated gas into the outdoor condenser coil.

In the condenser coil, the hot refrigerant gas, being warmer than the outdoor air, first loses its superheat by heat transferred from the gas through the tubes and fins of the coil. The refrigerant now becomes saturated, part liquid, part vapor and then continues to give up heat until it condenses to a liquid alone. Once the vapor is fully liquefied, it continues to give up heat which subcools the liquid, and it is ready to repeat the cycle.

COOLING CYCLE

Cooling Only Models

When the contacts of the room thermostat close, making terminals R to Y and R to G, the low voltage circuit to the contactor is completed starting the compressor and outdoor fan motor. This also energizes the indoor blower through the normally open contacts of the EBTDR on models equipped with PSC type blower motors, and through the blower relay on models equipped with EEM blower motors.

When the thermostat is satisfied, breaking the circuit between R to Y and R to G, the compressor and outdoor fan motor will stop. The indoor blower will stop after the fan off delay.

If the room thermostat fan selector switch should be set to the "on" position then the indoor blower would run continuously rather than cycling with the compressor.

Heat Pump Models

Any time the room thermostat is switched to cool, the O terminal is energized. This energizes the 24 volt coil on the reversing valve and switches it to the cooling position.

DP[13-14]CH/HH**41A*

When the contacts of the room thermostat close, this closes the circuit from R to Y and R to G in the unit.

This energizes the compressor contactor and will energize the indoor blower following the EBTDR 7 second fan on delay on models equipped with PSC type blower motors, and instantly on models equipped with EEM blower motors with the EEM motor.

When the thermostat is satisfied, it opens its contacts breaking the low voltage circuit causing the compressor contactor to open and indoor fan to stop after the EBTDR 65 second delay on models equipped with PSC type blower motors, and after the programmed 60 second off delay on models equipped with EEM blower motors with the EEM motor.

If the room thermostat fan selector switch should be set to the "on" position then the indoor blower would run continuously rather than cycling with the compressor.

HEATING CYCLE

Cooling Only Units

NOTE: The following only applies if the cooling only unit has an approved electric heat kit installed for heating. If auxiliary electric heaters should be used, they may be controlled by outdoor thermostats (OT18-60A or OT/EHR18-60A).

DPC Models with PSC Type Blower Motors

With the thermostat set to the heat position and a call for heat, R to W will be energized. This will energize the electric heat sequencers. When the normally open contacts of the heat sequencers close, this will energize the electric resistance heat and also the 240 volt coil on the isolation relay in the control panel. The normally open contacts of the isolation relay will close energizing the indoor blower motor through the normally closed contacts of the EBTDR.

When the thermostat is satisfied, this breaks the circuit from R to W. This will turn off the electric heaters, and the indoor blower after the programmed 60 second off delay on 5 ton units with the EEM motor.

DPC Models Equipped with EEM Blower Motors

With the thermostat set to the heat position and a call for heat, R to W will be energized. This will energize the electric heat sequencers and the EEM motor. The electric heat will be energized through the normally open contacts of the electric heat sequencers. The indoor blower will be energized through W from the thermostat.

When the thermostat is satisfied, this breaks the circuit from R to W. This will turn off the electric heaters, and the indoor blower after the programmed 60 second off delay .

Heat Pump Units

On a call for first stage heat, the contacts of the room thermostat close. This energizes terminals R to Y and R to G, the low voltage circuit to the contactor is completed starting the compressor and outdoor fan motor. This also energizes the indoor blower through the normally open contacts of the EBTDR after a 7 second on delay on models equipped with PSC type blower motors, and instantly on models equipped with EEM blower motors.

SYSTEM OPERATION

When the thermostat is satisfied, breaking the circuit between R to Y and R to G, the compressor and outdoor fan motor will stop. The indoor blower will stop after the EBTDR 65 second off delay on models equipped with PSC type blower motors, and after the programmed 60 second off delay on models equipped with EEM blower motors .

When auxiliary electric heaters are used, a two stage heating single stage cooling thermostat would be installed.

Should the second stage heating contacts in the room thermostat close, which would be wired to W1 at the unit low voltage connections, this would energize the coil(s) of the electric heat relay(s). Contacts within the relay(s) will close, bringing on the electric resistance heaters.

If auxiliary electric heaters should be used, they may be controlled by outdoor thermostats (OT18-60A or OT/EHR18-60A).

Emergency Heat Mode (Heat Pumps)

NOTE: The following only applies if the unit has an approved electric heat kit installed for auxiliary heating.

DPH Models Equipped with PSC Type Blower Motors

With the thermostat set to the emergency heat position and a call for 2nd stage heat, R to W1 will be energized. This will energize the electric heat sequencers. When the normally open contacts of the heat sequencers close, this will energize the electric resistance heat and also the 240 volt coil on the isolation relay in the control panel. The normally open contacts of the isolation relay will close energizing the indoor blower motor through the normally closed contacts of the EBTDR.

DPH Models Equipped with EEM Blower Motors

With the thermostat set to the emergency heat position and a call for 2nd stage heat, R to W1 will be energized. This will energize the electric heat sequencers and the EEM motor. The electric heat will be energized through the normally open contacts of the electric heat sequencers. The indoor blower will be energized through W from the thermostat.

DEFROST CYCLE

Package Heat Pumps

The defrosting of the outdoor coil is jointly controlled by the defrost control board and the defrost thermostat.

DP[13-14]CH/HH**41A*

Solid State Defrost Control

During operation the power to the circuit board is controlled by a temperature sensor, which is clamped to a feeder tube entering the outdoor coil. Defrost timing periods of 30, 60, or 90 minutes may be selected by setting the circuit board jumper to 30, 60, or 90 respectively. Accumulation of time for the timing period selected starts when the sensor closes (approximately $32 \pm 2^\circ$ F), and when the room thermostat calls for heat. At the end of the timing period, the unit's defrost cycle will be initiated provided the sensor remains closed. When the sensor opens (approximately 60° F), the defrost cycle is terminated and the timing period is reset. If the defrost cycle is not terminated due to the sensor temperature, a twelve minute override interrupts the unit's defrost period.

FAN OPERATION

Continuous Fan Mode

Models Equipped with PSC Type Blower Motors

If the thermostat calls for continuous fan, the indoor blower will be energized from the normally open contacts of the EBTDR after a 7 second delay.

Anytime there is a call for continuous fan, the indoor blower will be energized through the normally open contacts of the EBTDR, regardless of a call for heat or cool.

If the thermostat is not calling for heat or cool, and the fan switch on the thermostat is returned to the automatic position, the fan will stop after a 65 second delay.

Continuous Fan Mode

Models Equipped With EEM Blower Motors

If the thermostat calls for continuous fan, the indoor blower will be energized from the G terminal of the thermostat to the EEM blower motor.

If a call for heat or cool occurs during a continuous fan call, the EEM motor will always recognize the call for the highest speed and ignore the lower speed call.

If the thermostat is not calling for heat or cool, and the fan switch on the thermostat is returned to the automatic position, the fan will stop after the programmed 60 second off delay on units with the EEM motor.

SYSTEM OPERATION

Typical Package Cooling

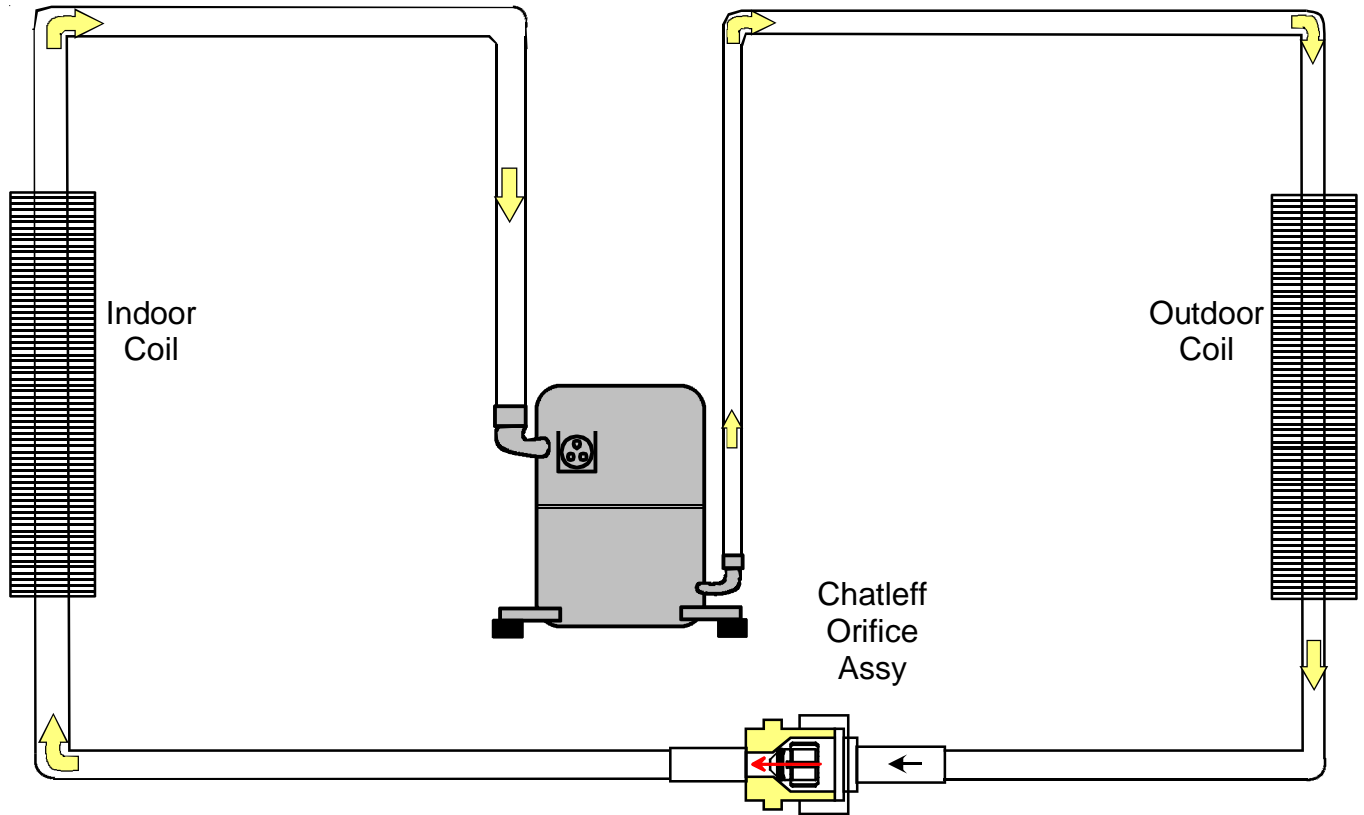

Restrictor Orifice Assembly in Cooling Operation

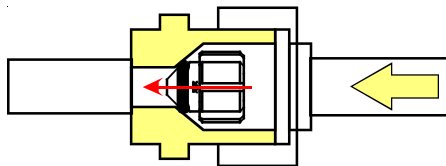

In the cooling mode the orifice is pushed into its seat forcing refrigerant to flow through the metered hole in the center of the orifice.

SYSTEM OPERATION

Typical Heat Pump System in Cooling

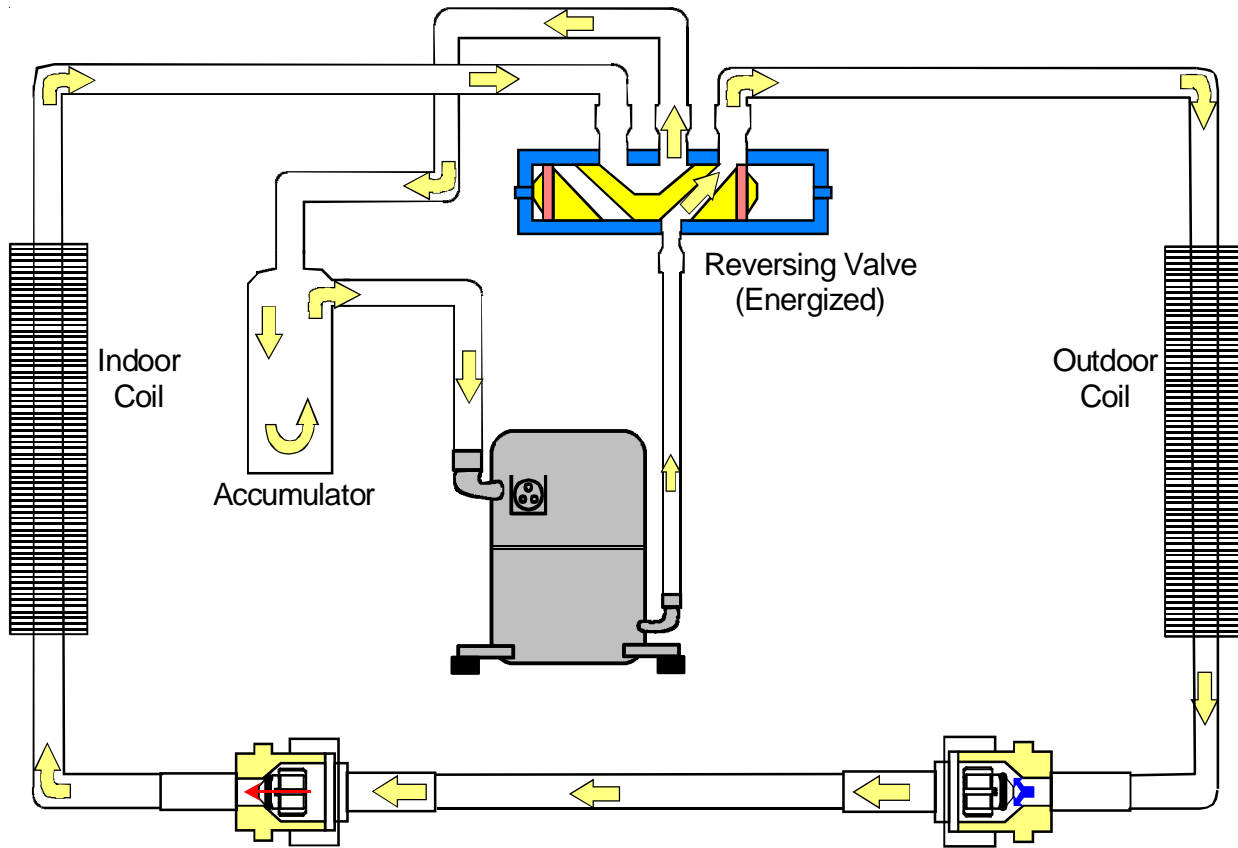

Typical Heat Pump System in Heating

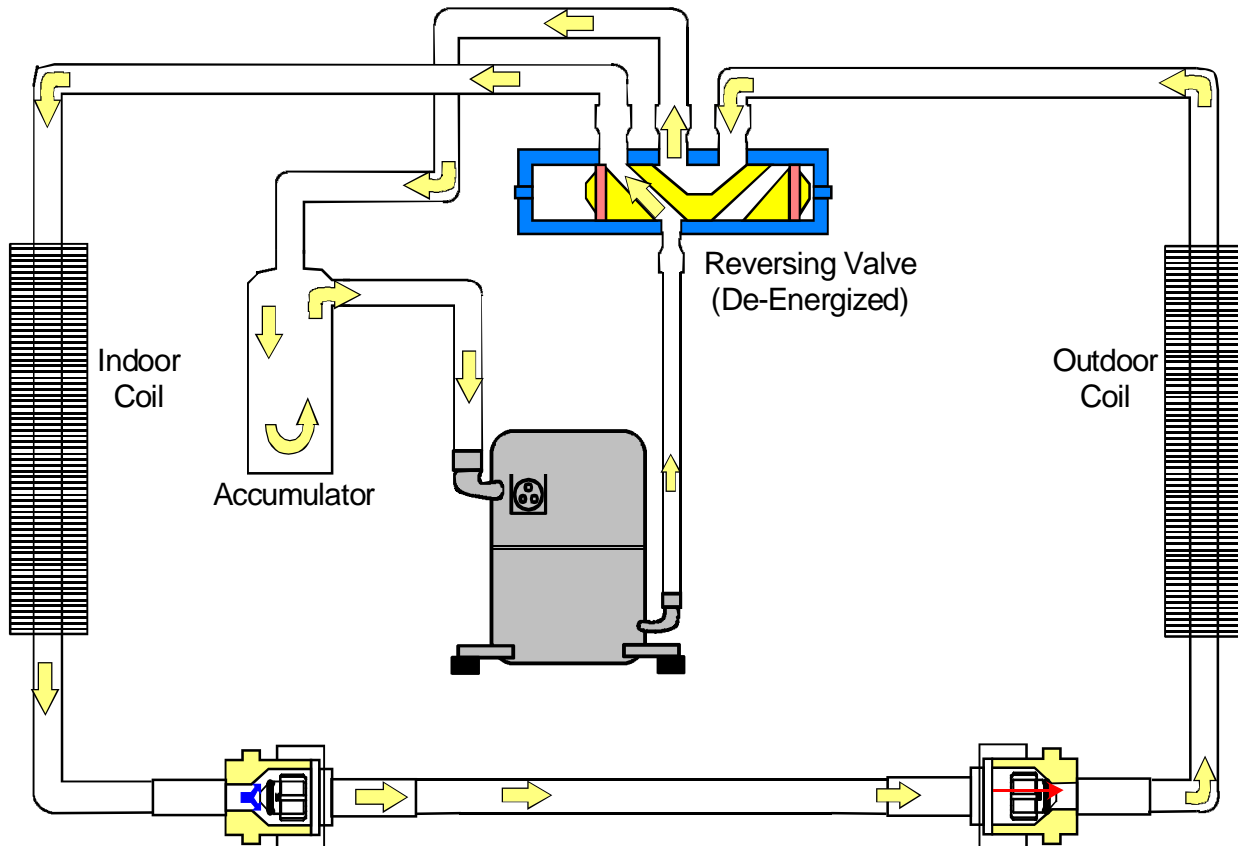

SCHEDULED MAINTENANCE

The owner should be made aware of the fact, that, as with any mechanical equipment the Package Cooling and Heat Pump units require regularly scheduled maintenance to preserve high performance standards, prolong the service life of the equipment, and lessen the chances of costly failure.

In many instances the owner may be able to perform some of the maintenance; however, the advantage of a service contract, which places all maintenance in the hands of a trained serviceman, should be pointed out to the owner.

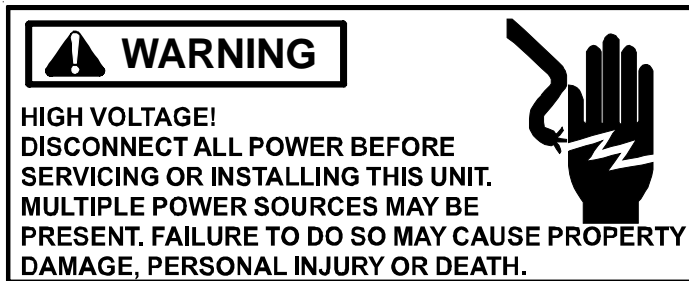

ONCE A MONTH

1. Inspect the return filters of the evaporator unit and clean or change if necessary.

NOTE: Depending on operation conditions, it may be necessary to clean the filters more often. If permanent type filters are used, they should be washed with warm water, dried and sprayed with an adhesive according to manufacturers recommendations.

2. When operating on the cooling cycle, inspect the condensate line piping from the evaporator coil. Make sure the piping is clear for proper condensate flow.

ONCE A YEAR

Qualified Service Personnel Only

1. Clean the indoor and outdoor coils.
2. Clean the casing of the outdoor unit inside and out.
3. Motors are permanently lubricated and do not require oiling. TO AVOID PREMATURE MOTOR FAILURE, DO NOT OIL.
4. Manually rotate the outdoor fan and indoor blower to be sure they run freely.
5. Inspect the control panel wiring, compressor connections, and all other component wiring to be sure all connections are tight. Inspect wire insulation to be certain that it is good.

6. Check the contacts of the compressor contactor. If they are burned or pitted, replace the contactor.
7. Using a halide or electronic leak detector, check all piping and etc. for refrigerant leaks.
8. Check the combustion chamber (Heat Exchanger) for soot, scale, etc. Inspect all burners for lint and proper positioning.
9. Start the system, using the proper instrumentation check gas inlet and manifold pressures, burner flame and microamp signal. Adjust if necessary.
10. Start the system and run both a Cooling & Heating Performance Test. If the results of the test are not satisfactory, see the "Service Problem Analysis" Chart of the possible cause.

TEST EQUIPMENT

Proper test equipment for accurate diagnosis is as essential as regular hand tools.

The following is a must for every service technician and service shop:

1. Thermocouple type temperature meter - measure dry bulb temperature.
2. Sling psychrometer- measure relative humidity and wet bulb temperature.
3. Amprobe - measure amperage and voltage.
4. Volt-Ohm Meter - testing continuity, capacitors, and motor windings.
5. Accurate Leak Detector - testing for refrigerant leaks.
6. High Vacuum Pump - evacuation.
7. Electric Vacuum Gauge, Manifold Gauges and high vacuum hoses - to measure and obtain proper vacuum.
8. Accurate Electronic Scale - measure proper refrigerant charge.
9. Inclined Manometer - measure static pressure and pressure drop across coils.

Other recording type instruments can be essential in solving abnormal problems; however, in many instances they may be rented from local sources.

Proper equipment promotes faster, more efficient service, and accurate repairs with less call backs.

SERVICING

COOLING /HEAT PUMP- SERVICE ANALYSIS GUIDE

Complaint	No Cooling							Unsatisfactory Cooling/Heating							System Operating Pressures				Test Method Remedy	See Service Procedure Ref.	
	SYMPTOM	System will not start	Compressor will not start - fan runs	Comp. and Cond. Fan will not start	Evaporator fan will not start	Condenser fan will not start	Compressor runs - goes off on overload	Compressor cycles on overload	System runs continuously - little cooling/mfg	Too cool and then too warm	Not cool enough on warm days	Certain areas too cool, others too warm	Compressor is noisy	System runs - blows cold air in heating	Unit will not terminate defrost	Unit will not defrost	Low suction pressure	Low head pressure			High suction pressure
Power Failure	●																			Test Voltage	S-1
Blown Fuse	●		●	●																Inspect Fuse Size & Type	S-1
Unbalanced Power, 3PH		●					●	●												Test Voltage	S-1
Loose Connection	●		●	●			●													Inspect Connection - Tighten	S-2, S-3
Shorted or Broken Wires	●	●	●	●	●	●														Test Circuits With Ohmmeter	S-2, S-3
Open Fan Overload				●	●															Test Continuity of Overload	S-17A
Faulty Thermostat	●		●	●				●												Test continuity of Thermostat & Wiring	S-3
Faulty Transformer	●		●																	Check control circuit with voltmeter	S-4
Shorted or Open Capacitor		●		●	●	●	●													Test Capacitor	S-15
Internal Compressor Overload Open		●											◆							Test Continuity of Overload	S-17A
Shorted or Grounded Compressor		●				●														Test Motor Windings	S-17B
Compressor Stuck		●				●	●						◆							Use Test Cord	S-17D
Faulty Compressor Contactor			●		●	●														Test continuity of Coil & Contacts	S-7, S-8
Faulty Fan Control				●																Test continuity of Coil And Contacts	S-7, S-9
Open Control Circuit				●																Test Control Circuit with Voltmeter	S-4
Low Voltage		●				●	●													Test Voltage	S-1
Faulty Evap. Fan Motor				●												●	◆			Repair or Replace	S-16
Shorted or Grounded Fan Motor					●													●		Test Motor Windings	S-16A, D
Improper Cooling Anticipator							●	●												Check resistance of Anticipator	S-3B
Shortage of Refrigerant							●	●					◆			●	●			Test For Leaks, Add Refrigerant	S-101,103
Restricted Liquid Line							●	●								●	●	●		Remove Restriction, Replace Restricted Part	S-112
Open Element or Limit on Elec. Heater													◆							Test Heater Element and Controls	S-26,S-27
Dirty Air Filter							●	●	●							●			◆	Inspect Filter-Clean or Replace	
Dirty Indoor Coil							●	●	●							●			◆	Inspect Coil - Clean	
Not enough air across Indoor Coil							●	●	●							●			◆	Check Blower Speed, Duct Static Press, Filter	S-200
Too much air across Indoor Coil								●									◆	●		Reduce Blower Speed	S-200
Overcharge of Refrigerant						●	●					●	◆					●	●	Recover Part of Charge	S-113
Dirty Outdoor Coil						●	●		●							◆			●	Inspect Coil - Clean	
Noncondensibles						●		●					◆							Recover Charge, Evacuate, Recharge	S-114
Recirculation of Condensing Air						●		●												Remove Obstruction to Air Flow	
Infiltration of Outdoor Air							●	●	●											Check Windows, Doors, Vent Fans, Etc.	
Improperly Located Thermostat					●			●												Relocate Thermostat	
Air Flow Unbalanced							●	●												Readjust Air Volume Dampers	
System Undersized							●	●												Refigure Cooling Load	
Broken Internal Parts												●	◆							Replace Compressor	S-115
Broken Valves							●										●	●		Test Compressor Efficiency	S-104
Inefficient Compressor							●										●	●		Test Compressor Efficiency	S-104
Loose Hold-down Bolts												●								Tighten Bolts	
Faulty Reversing Valve					●														◆	Replace Valve or Solenoid	S-21, 122
Faulty Defrost Control																			◆	Test Control	S-24
Faulty Defrost Thermostat																			◆	Test Defrost Thermostat	S-25
Flowrator Not Seating Properly							●										●	●		Check Flowrator & Seat or Replace Flowrator	S-111

● Cooling or Heating Cycle (Heat Pump)

◆ Heating Cycle Only (Heat Pump)

SERVICING

S-1 CHECKING VOLTAGE

 **WARNING**



**HIGH VOLTAGE!
DISCONNECT ALL POWER BEFORE
SERVICING OR INSTALLING THIS UNIT.
MULTIPLE POWER SOURCES MAY BE
PRESENT. FAILURE TO DO SO MAY CAUSE PROPERTY
DAMAGE, PERSONAL INJURY OR DEATH.**

1. Remove doors, control panel cover, etc. from unit being tested.

With power ON:

 **WARNING**

LINE VOLTAGE NOW PRESENT.

2. Using a voltmeter, measure the voltage across terminals L1 and L2 of the contactor for single phase units, and L3, for 3 phase units.
3. No reading - indicates open wiring, open fuse(s) no power or etc. from unit to fused disconnect service. Repair as needed.
4. With ample voltage at line voltage connectors, energize the unit.
5. Measure the voltage with the unit starting and operating, and determine the unit Locked Rotor Voltage.

Locked Rotor Voltage is the actual voltage available at the compressor during starting, locked rotor, or a stalled condition. Measured voltage should be above minimum listed in chart below.

To measure Locked Rotor Voltage attach a voltmeter to the run "R" and common "C" terminals of the compressor, or to the T₁ and T₂ terminals of the contactor. Start the unit and allow the compressor to run for several seconds, then shut down the unit. Immediately attempt to restart the unit while measuring the Locked Rotor Voltage.

6. Should read within the voltage tabulation as shown. If the voltage falls below the minimum voltage, check the line wire size. Long runs of undersized wire can cause low voltage. If wire size is adequate, notify the local power company in regards to either low or high voltage.

Unit Supply Voltage		
Voltage	Min.	Max.
460	437	506
208/230	198	253

S-2 CHECKING WIRING

 **WARNING**



**HIGH VOLTAGE!
DISCONNECT ALL POWER BEFORE
SERVICING OR INSTALLING THIS UNIT.
MULTIPLE POWER SOURCES MAY BE
PRESENT. FAILURE TO DO SO MAY CAUSE PROPERTY
DAMAGE, PERSONAL INJURY OR DEATH.**

1. Check wiring visually for signs of overheating, damaged insulation and loose connections.
2. Use an ohmmeter to check continuity of any suspected open wires.
3. If any wires must be replaced, replace with comparable gauge and insulation thickness.

S-3 CHECKING THERMOSTAT, WIRING, AND ANTICIPATOR

S-3A THERMOSTAT AND WIRING

 **WARNING**

LINE VOLTAGE NOW PRESENT.

With power ON and thermostat calling for cooling.

1. Use a voltmeter to verify 24 volts present at thermostat wires C and R.
2. If no voltage present, check transformer and transformer wiring. If 24 volts present, proceed to step 3.
3. Use a voltmeter to check for 24 volts at thermostat wires C and Y.
4. No voltage indicates trouble in the thermostat, wiring or external transformer source.
5. Check the continuity of the thermostat and wiring. Repair or replace as necessary.

Indoor Blower Motor

With power ON:

 **WARNING**

LINE VOLTAGE NOW PRESENT.

1. Use a voltmeter to verify 24 volts present at thermostat wires C and R.
2. If no voltage present, check transformer and transformer wiring. If 24 volts present, proceed to step 3.

SERVICING

3. Set fan selector switch at thermostat to "ON" position.
4. With voltmeter, check for 24 volts at wires C and G.
5. No voltage, indicates the trouble is in the thermostat or wiring.
6. Check the continuity of the thermostat and wiring. Repair or replace as necessary.

S-3B COOLING ANTICIPATOR

The cooling anticipator is a small heater (resistor) in the thermostat. During the "off" cycle it heats the bimetal element helping the thermostat call for the next cooling cycle. This prevents the room temperature from rising too high before the system is restarted. A properly sized anticipator should maintain room temperature within 1 1/2 to 2 degree range.

The anticipator is supplied in the thermostat and is not to be replaced. If the anticipator should fail for any reason, the thermostat must be changed.

S-3C HEATING ANTICIPATOR

The heating anticipator is a wire-wound adjustable heater, which is energized during the "ON" cycle to help prevent overheating of the conditioned space.

The anticipator is a part of the thermostat and if it should fail for any reason, the thermostat must be replaced. See the following for recommended heater anticipator setting.

To determine the proper setting, use an amp meter to measure the amperage on the "W" wire going to the thermostat.

Use an amprobe as shown below. Wrap 10 turns of thermostat wire around the stationary jaw of the amprobe and divide the reading by 10.

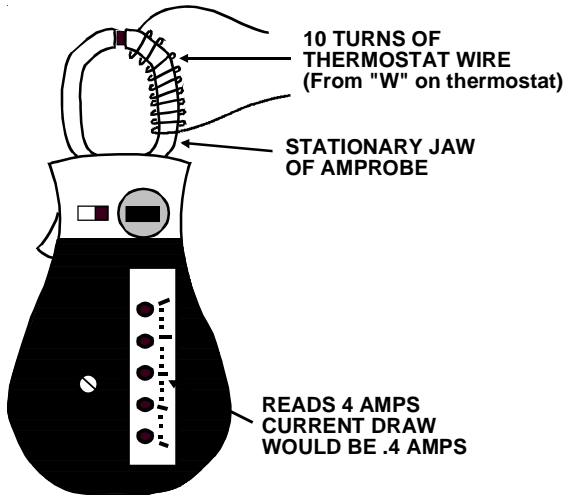

Checking Heat Anticipator Amp Draw

S-4 CHECKING TRANSFORMER AND CONTROL CIRCUIT

A step-down transformer (208/240 volt primary to 24 volt secondary) is provided with each package unit. This allows ample capacity for use with resistance heaters.

 **WARNING**



HIGH VOLTAGE!
DISCONNECT ALL POWER BEFORE SERVICING OR INSTALLING THIS UNIT. MULTIPLE POWER SOURCES MAY BE PRESENT. FAILURE TO DO SO MAY CAUSE PROPERTY DAMAGE, PERSONAL INJURY OR DEATH.

1. Remove control panel cover or etc. to gain access to transformer.

With power ON:

 **WARNING**

LINE VOLTAGE NOW PRESENT.

2. Using a voltmeter, check voltage across secondary voltage side of transformer (R to C).
3. No voltage indicates faulty transformer, bad wiring, or bad splices.
4. Check transformer primary voltage at incoming line voltage connections and/or splices.
5. If line voltage is present at the primary voltage side of the transformer and 24 volts is not present on the secondary side, then the transformer is inoperative. Replace.

S-7 CHECKING CONTACTOR AND/OR RELAYS

The compressor contactor and other relay holding coils are wired into the low or line voltage circuits. When the control circuit is energized the coil pulls in the normally open contacts or opens the normally closed contacts. When the coil is de-energized, springs return the contacts to their normal position.

 **WARNING**

DISCONNECT POWER SUPPLY BEFORE SERVICING.

1. Remove the leads from the holding coil.
2. Using an ohmmeter, test across the coil terminals.

If the coil does not test continuous, replace the relay or contactor.

S-8 CHECKING CONTACTOR CONTACTS

 **WARNING**

DISCONNECT POWER SUPPLY BEFORE SERVICING.

SERVICING

SINGLE PHASE

1. Disconnect the wire leads from the terminal (T) side of the contactor.
2. With power ON, energize the contactor.

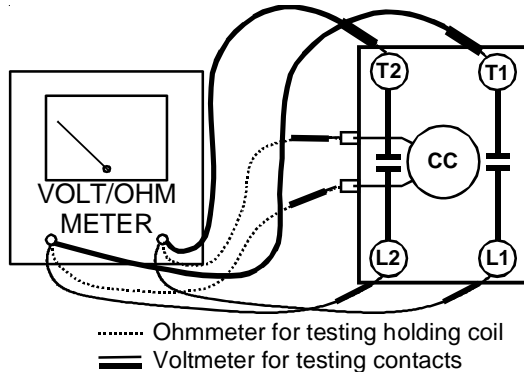

TESTING COMPRESSOR CONTACTOR (Single Phase)

3. Using a voltmeter, test across terminals.
 - A. L1 to L2 - No voltage. Check breaker or fuses on main power supply. If voltage present, proceed to step B.
 - B. T1 to T2 - Meter should read the same as L1 to L2 in step A. If voltage readings are not the same as step A, replace contactor.

S-9 CHECKING FAN RELAY CONTACTS

The Electronic Blower Time Delay Relay is used on models equipped with PSC type blower motors.

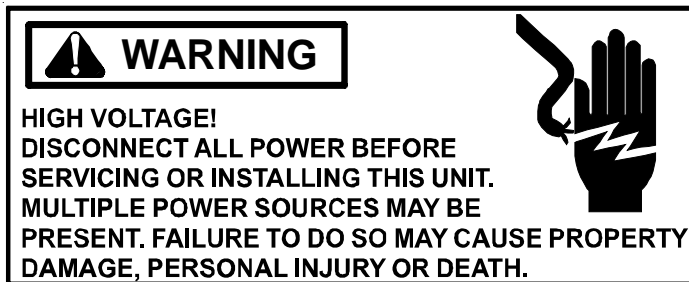

Checking EBTD High Voltage Contacts

1. With power off, remove wires from terminals NC, COM, and NO.
2. Using a VOM, check for resistance from NO to COM. Should read open. Next, check for resistance from NC to COM. Should read closed.

3. If not as in steps 1 and 2, replace EBTD.

Checking EBTD Contact Operation

With power on:



1. Set the thermostat to the fan "on" position.
2. Check for 24 volts at the C and G terminals of the EBTD.
3. If no voltage present, check fan circuit from thermostat. If 24 volts present, proceed to step 4.
4. Using a VOM, check for line voltage from the purple wire at the transformer (terminal 3 on 240 volt units, terminal 2 on 208 volt units) to terminal NO on the EBTD. Should read line voltage. If no voltage present, check line voltage wiring in unit. If line voltage present, proceed to step 5.
5. Using a VOM, check for line voltage from the purple wire at the transformer (terminal 3 on 240 volt units, terminal 2 on 208 volt units) to the COM terminal on the EBTD. Should read line voltage. If not as above, replace EBTD.

PSC Type Blower Motor Models Only

Heat pump and cooler models equipped with PSC type blower motors have an isolation relay with a 240 volt holding coil in addition to the EBTD.



Turn power off.

Testing relay holding coil

1. Remove the leads from the holding coil terminals 1 and 3.
2. Using an ohmmeter, test across the coil terminals 1 and 3. If the coil does not test continuous, replace the relay.

Testing relay contacts



Turn power off.

1. Using a VOM, test resistance across relay terminals 2 and 4. Should read open.
2. Turn power on.

SERVICING



3. Apply 240 volts to coil terminals 1 and 3.
4. Using a VOM, check for 240 volts from terminals 3 and 1 of relay. Should read 240 volts. In no voltage, check wiring from heater kit to relay. If voltage present, proceed to step 5.
5. Using a VOM, check for 240 volts from L1 at contactor to terminal 4 of relay. Should read 240 volts. Next check from L1 at contactor to terminal 2 of relay. Should read 240 volts.

If not as above, replace relay.

S-11 CHECKING LOSS OF CHARGE PROTECTOR

(Heat Pump Models)

The loss of charge protector senses the pressure in the liquid line and will open its contacts on a drop in pressure. The low pressure control will automatically reset itself with a rise in pressure.

The low pressure control is designed to cut-out (open) at approximately 22 ± 7 PSIG. It will automatically cut-in (close) at approximately 50 ± 7 PSIG.

Test for continuity using a VOM and if not as above, replace the control.

S-12 CHECKING HIGH PRESSURE CONTROL

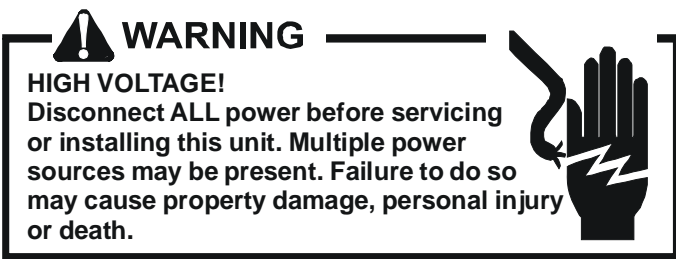

The high pressure control senses the pressure in the liquid line. If abnormally high discharge pressures develop, the contacts of the control open, breaking the control circuit before the compressor motor overloads. This control is automatically reset.

1. Using an ohmmeter, check across terminals of high pressure control, with wire removed. If not continuous, the contacts are open.
3. Attach a gauge to the access fitting on the liquid line.

With power ON:



4. Start the system and place a piece of cardboard in front of the condenser coil, raising the condensing pressure.
5. Check pressure at which the high pressure control cuts-out.

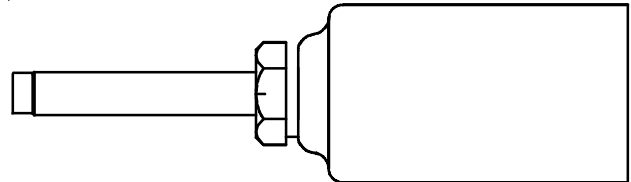

If it cuts-out at $610 \text{ PSIG} \pm 10 \text{ PSIG}$, it is operating normally (See causes for high head pressure in Service Problem Analysis Guide). If it cuts out below this pressure range, replace the control. The control should reset at $420 \text{ PSIG} \pm 25 \text{ PSIG}$.

S-15 CHECKING CAPACITOR

CAPACITOR, RUN

A run capacitor is wired across the auxiliary and main windings of a single phase permanent split capacitor motor. The capacitor's primary function is to reduce the line current while greatly improving the torque characteristics of a motor. This is accomplished by using the 90° phase relationship between the capacitor current and voltage in conjunction with the motor windings so that the motor will give two phase operation when connected to a single phase circuit. The capacitor also reduces the line current to the motor by improving the power factor.

CAPACITOR, START

SCROLL COMPRESSOR MODELS

Hard start components are not required on Scroll compressor equipped units due to a non-replaceable check valve located in the discharge line of the compressor. However hard start kits are available and may improve low voltage starting characteristics.

This check valve closes off high side pressure to the compressor after shut down allowing equalization through the scroll flanks. Equalization requires only about one or two seconds during which time the compressor may turn backwards.

Your unit comes with a 180-second anti-short cycle to prevent the compressor from starting and running backwards.

MODELS EQUIPPED WITH A HARD START DEVICE

A start capacitor is wired in parallel with the run capacitor to increase the starting torque. The start capacitor is of the electrolytic type, rather than metallized polypropylene as used in the run capacitor.

SERVICING

A switching device must be wired in series with the capacitor to remove it from the electrical circuit after the compressor starts to run. Not removing the start capacitor will overheat the capacitor and burn out the compressor windings.

These capacitors have a 15,000 ohm, 2 watt resistor wired across its terminals. The object of the resistor is to discharge the capacitor under certain operating conditions, rather than having it discharge across the closing of the contacts within the switching device such as the Start Relay, and to reduce the chance of shock to the servicer. See the Servicing Section for specific information concerning capacitors.

RELAY, START

A potential or voltage type relay is used to take the start capacitor out of the circuit once the motor comes up to speed. This type of relay is position sensitive. The normally closed contacts are wired in series with the start capacitor and the relay holding coil is wired parallel with the start winding. As the motor starts and comes up to speed, the increase in voltage across the start winding will energize the start relay holding coil and open the contacts to the start capacitor.

Two quick ways to test a capacitor are a resistance and a capacitance check.

S-15A RESISTANCE CHECK

WARNING

HIGH VOLTAGE!
DISCONNECT ALL POWER BEFORE
SERVICING OR INSTALLING THIS UNIT.
MULTIPLE POWER SOURCES MAY BE
PRESENT. FAILURE TO DO SO MAY CAUSE PROPERTY
DAMAGE, PERSONAL INJURY OR DEATH.

1. Discharge capacitor and remove wire leads.

WARNING

DISCHARGE CAPACITOR THROUGH A 20 TO 30 OHM
RESISTOR BEFORE HANDLING.

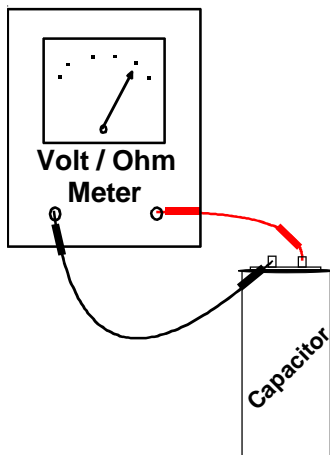

TESTING CAPACITOR RESISTANCE

2. Set an ohmmeter on its highest ohm scale and connect the leads to the capacitor -

- A. Good Condition - indicator swings to zero and slowly returns to infinity. (Start capacitor will bleed resistor will not return to infinity. It will still read the resistance of the resistor).
- B. Shorted - indicator swings to zero and stops there - replace.
- C. Open - no reading - replace. (Start capacitor would read resistor resistance).

S-15B CAPACITANCE CHECK

WARNING

DISCHARGE CAPACITOR THROUGH A 20 TO 30 OHM
RESISTOR BEFORE HANDLING.

Using a hookup as shown below, take the amperage and voltage readings and use them in the formula:

$$\text{Capacitance (MFD)} = \frac{2650 \times \text{Amperage}}{\text{Voltage}}$$

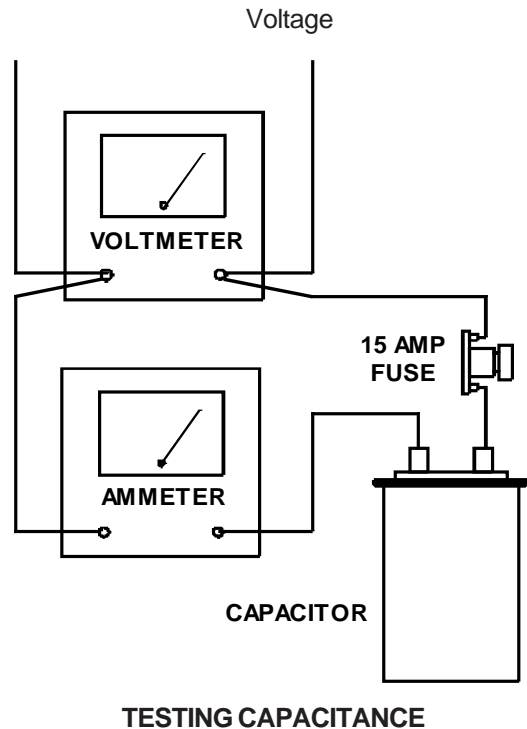

TESTING CAPACITANCE

SERVICING

S-16 CHECKING MOTORS

S-16A CHECKING FAN AND BLOWER MOTOR WINDINGS (PSC MOTORS)

Applies only to units with PSC Motors

The auto reset fan motor overload is designed to protect the motor against high temperature and high amperage conditions by breaking the common circuit within the motor, similar to the compressor internal overload. However, heat generated within the motor is faster to dissipate than the compressor, allow at least 45 minutes for the overload to reset, then retest.

 **WARNING**



HIGH VOLTAGE!
DISCONNECT ALL POWER BEFORE SERVICING OR INSTALLING THIS UNIT. MULTIPLE POWER SOURCES MAY BE PRESENT. FAILURE TO DO SO MAY CAUSE PROPERTY DAMAGE, PERSONAL INJURY OR DEATH.

1. Remove the motor leads from its respective connection points and capacitor (if applicable).
2. Check the continuity between each of the motor leads.
3. Touch one probe of the ohmmeter to an unpainted end of the motor frame (ground) and the other probe in turn to each lead.

If the windings do not test continuous or a reading is obtained from any lead to ground, replace the motor.

S-16D CHECKING EEM (ENERGY EFFICIENT MOTOR) MOTORS

Applies only to units with EEM Motors

The EEM Motor is a one piece, fully encapsulated, 3 phase brushless DC (single phase AC input) motor with ball bearing construction. Unlike the ECM 2.3/2.5 motors, the EEM features an integral control module.

Note: The GE TECMate will not currently operate the EEM motor.

1. Using a voltmeter, check for 230 volts to the motor connections L and N. If 230 volts is present, proceed to step 2. If 230 volts is not present, check the line voltage circuit to the motor.
2. Using a voltmeter, check for 24 volts from terminal C to either terminal 1, 2, 3, 4 or 5, depending on which tap is being used, at the motor. If voltage present, proceed to step 3. If no voltage, check 24 volt circuit to motor.
3. If voltage was present in steps 1 and 2, the motor has failed and will need to be replaced.

Note: When replacing motor, ensure the belly band is between the vents on the motor and the wiring has the proper drip loop to prevent condensate from entering the motor.

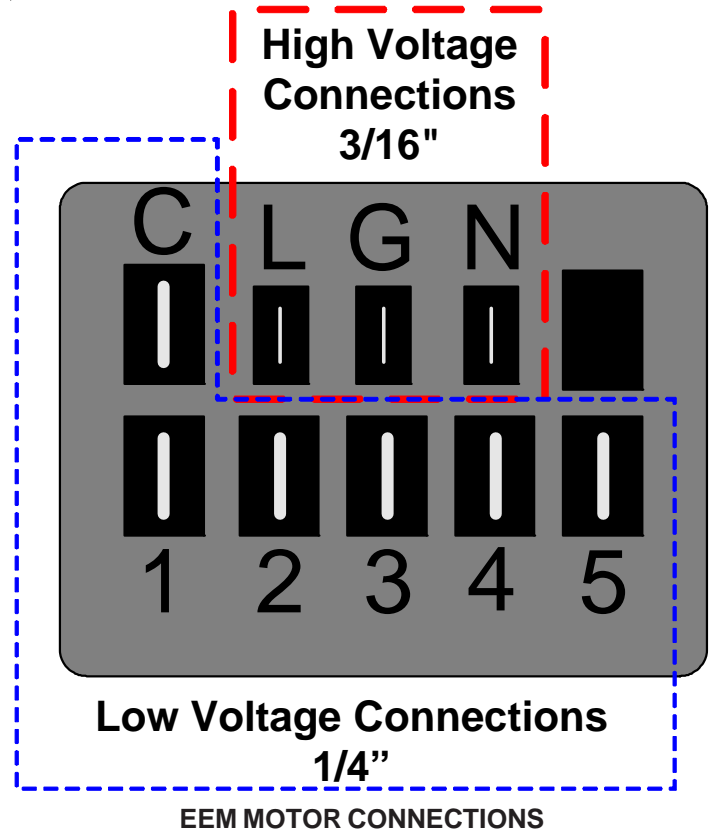

S-17 CHECKING COMPRESSOR WINDINGS

 **WARNING**

HERMETIC COMPRESSOR ELECTRICAL TERMINAL VENTING CAN BE DANGEROUS. WHEN INSULATING MATERIAL WHICH SUPPORTS A HERMETIC COMPRESSOR OR ELECTRICAL TERMINAL SUDDENLY DISINTEGRATES DUE TO PHYSICAL ABUSE OR AS A RESULT OF AN ELECTRICAL SHORT BETWEEN THE TERMINAL AND THE COMPRESSOR HOUSING, THE TERMINAL MAY BE EXPELLED, VENTING THE VAPOR AND LIQUID CONTENTS OF THE COMPRESSOR HOUSING AND SYSTEM.

If the compressor terminal PROTECTIVE COVER and gasket (if required) is not properly in place and secured, there is a remote possibility if a terminal vents, that the vaporous and liquid discharge can be ignited, spouting flames several feet, causing potentially severe or fatal injury to anyone in its path.

This discharge can be ignited external to the compressor if the terminal cover is not properly in place and if the discharge impinges on a sufficient heat source.

Ignition of the discharge can also occur at the venting terminal or inside the compressor, if there is sufficient contaminant air present in the system and an electrical arc occurs as the terminal vents.

SERVICING

Ignition cannot occur at the venting terminal without the presence of contaminant air, and cannot occur externally from the venting terminal without the presence of an external ignition source.

Therefore, proper evacuation of a hermetic system is essential at the time of manufacture and during servicing.

To reduce the possibility of external ignition, all open flame, electrical power, and other heat sources should be extinguished or turned off prior to servicing a system.

If the following test indicates shorted, grounded or open windings, see procedure S-19 for the next steps to be taken.

S-17A RESISTANCE TEST

Each compressor is equipped with an internal overload.

The line break internal overload senses both motor amperage and winding temperature. High motor temperature or amperage heats the disc causing it to open, breaking the common circuit within the compressor on single phase units. The three phase internal overload will open all three legs.

Heat generated within the compressor shell, usually due to recycling of the motor, high amperage or insufficient gas to cool the motor, is slow to dissipate, allow at least three to four hours for it to cool and reset, then retest.

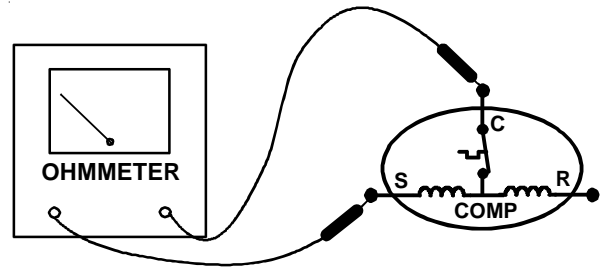

TESTING COMPRESSOR WINDINGS

If either winding does not test continuous, replace the compressor.

NOTE: If an open compressor is indicated allow ample time for the internal overload to reset before replacing compressor.

S-17B GROUND TEST

If fuse, circuit breaker, ground fault protective device, etc., has tripped, this is a strong indication that an electrical problem exists and must be found and corrected. The circuit protective device rating must be checked and its maximum rating should coincide with that marked on the equipment nameplate.

With the terminal protective cover in place, it is acceptable to replace the fuse or reset the circuit breaker ONE TIME ONLY to see if it was just a nuisance opening. If it opens again, DO NOT continue to reset.

Disconnect all power to unit, making sure that all power legs are open.

1. DO NOT remove protective terminal cover. Disconnect the three leads going to the compressor terminals at the nearest point to the compressor.

WARNING

HIGH VOLTAGE!
DISCONNECT ALL POWER BEFORE
SERVICING OR INSTALLING THIS UNIT.
MULTIPLE POWER SOURCES MAY BE
PRESENT. FAILURE TO DO SO MAY CAUSE PROPERTY
DAMAGE, PERSONAL INJURY OR DEATH.

1. Remove the leads from the compressor terminals.

WARNING

SEE WARNINGS S-17 BEFORE REMOVING COMPRES-
SOR TERMINAL COVER.

2. Using an ohmmeter, test continuity between terminals S-R, C-R, and C-S, on single phase units or terminals T1, T2 and T3, on 3 phase units.

WARNING

DAMAGE CAN OCCUR TO THE GLASS EMBEDDED
TERMINALS IF THE LEADS ARE NOT PROPERLY
REMOVED. THIS CAN RESULT IN TERMINAL AND
HOT OIL DISCHARGING.

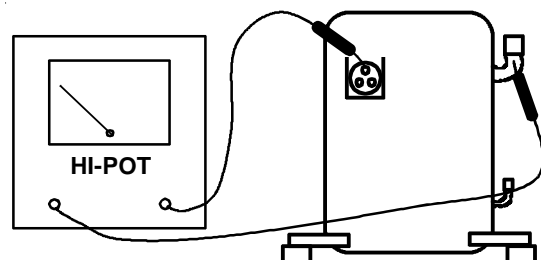

COMPRESSOR GROUND TEST

2. Identify the leads and using a Megger, Hi-Potential Ground Tester, or other suitable instrument which puts out a voltage between 300 and 1500 volts, check for a ground separately between each of the three leads and ground (such as an unpainted tube on the compressor). Do not use a low voltage output instrument such as a volt-ohmmeter.

SERVICING

3. If a ground is indicated, then carefully remove the compressor terminal protective cover and inspect for loose leads or insulation breaks in the lead wires.
4. If no visual problems indicated, carefully remove the leads at the compressor terminals.
Carefully retest for ground, directly between compressor terminals and ground.
5. If ground is indicated, replace the compressor.

S-17D OPERATION TEST

If the voltage, capacitor, overload and motor winding test fail to show the cause for failure:

 **WARNING**



**HIGH VOLTAGE!
DISCONNECT ALL POWER BEFORE
SERVICING OR INSTALLING THIS UNIT.
MULTIPLE POWER SOURCES MAY BE
PRESENT. FAILURE TO DO SO MAY CAUSE PROPERTY
DAMAGE, PERSONAL INJURY OR DEATH.**

1. Remove unit wiring from disconnect switch and wire a test cord to the disconnect switch.

NOTE: The wire size of the test cord must equal the line wire size and the fuse must be of the proper size and type.

2. With the protective terminal cover in place, use the three leads to the compressor terminals that were disconnected at the nearest point to the compressor and connect the common, start and run clips to the respective leads.
3. Connect good capacitors of the right MFD and voltage rating into the circuit.
4. With power ON, close the switch.

 **WARNING**

LINE VOLTAGE NOW PRESENT.

- A. If the compressor starts and continues to run, the cause for failure is somewhere else in the system.
- B. If the compressor fails to start - replace.

The condition of the scroll flanks is checked in the following manner.

1. Attach gauges to the high and low side of the system.
2. Start the system and run a "Cooling Performance Test.

If the test shows:

- a. Below normal high side pressure.
- b. Above normal low side pressure.
- c. Low temperature difference across coil.
- d. Low amp draw at compressor.

and the charge is correct, test the reversing valve if equipped (heat pump models only. See-S-21). If the reversing valves test good, the compressor is faulty - replace the compressor.

S-18 TESTING CRANKCASE HEATER (OPTIONAL ITEM)

Note: Not all compressors use crankcase heaters.

The crankcase heater must be energized a minimum of twenty-four (24) hours before the compressor is operated.

Crankcase heaters are used to prevent migration or accumulation of refrigerant in the compressor crankcase during the off cycles and prevents liquid slugging or oil pumping on start up. On some models, the crankcase heater is controlled by a crankcase heater thermostat that is wired in series with the crankcase heater.

A crankcase heater will not prevent compressor damage due to a floodback or over charge condition.

 **WARNING**

DISCONNECT POWER SUPPLY BEFORE SERVICING.

1. Disconnect the heater lead wires.
2. Using an ohmmeter, check heater continuity - should test continuous, if not, replace.

S-18A CHECKING CRANKCASE HEATER THERMOSTAT

Note: Not all models with crankcase heaters will have a crankcase heater thermostat.

1. Install a thermocouple type temperature test lead on the discharge line adjacent to the crankcase heater thermostat.
2. Check the temperature at which the control closes its contacts by lowering the temperature of the control. The crankcase heater thermostat should close at $67^{\circ}\text{F} \pm 5^{\circ}\text{F}$.
3. Check the temperature at which the control opens its contacts by raising the temperature of the control. The crankcase heater thermostat should open at $85^{\circ}\text{F} \pm 5^{\circ}\text{F}$.
4. If not as above, replace control.

S-21 CHECKING REVERSING VALVE AND SOLENOID

Occasionally the reversing valve may stick in the heating or cooling position or in the mid-position.

When stuck in the mid-position, part of the discharge gas from the compressor is directed back to the suction side, resulting in excessively high suction pressure. An increase in the suction line temperature through the reversing valve can also be measured. Check operation of the valve by starting the system and switching the operation from COOLING to HEATING cycle.

SERVICING

If the valve fails to change its position, test the voltage (24V) at the valve coil terminals, while the system is on the COOLING cycle.

If no voltage is registered at the coil terminals, check the operation of the thermostat and the continuity of the connecting wiring from the "O" terminal of the thermostat to the unit.

If voltage is registered at the coil, tap the valve body lightly while switching the system from HEATING to COOLING, etc. If this fails to cause the valve to switch positions, remove the coil connector cap and test the continuity of the reversing valve solenoid coil. If the coil does not test continuous - replace it.

If the coil test continuous and 24 volts is present at the coil terminals, the valve is inoperative - replace it.

S-24 TESTING DEFROST CONTROL

NOTE: PCBDM133 defrost controls have a three (3) minute compressor off cycle delay.

NOTE: The PCBDM133 defrost controls are shipped from the factory with the compressor delay option selected. This will de-energize the compressor contactor for 30 seconds on defrost initiation and defrost termination. If the jumper is set to Normal, the compressor will continue to run during defrost initiation and defrost termination. The control will also ignore the low pressure switch connected to R-PS1 and PS2 for 5 minutes upon defrost initiation and 5 minutes after defrost termination. To check the defrost control for proper sequencing, proceed as follows: With power ON; unit not running.

1. Jumper defrost thermostat by placing a jumper wire across the terminals "DFT" and "R" ("R-DFT" on PCBDM133) at defrost control board.
2. Connect jumper across test pins on defrost control board.
3. Set thermostat to call for heating. System should go into defrost within 21 seconds.
4. Immediately remove jumper from test pins.
5. Using VOM check for voltage across terminals "C & O" ("O-RV" on PCBDM133). Meter should read 24 volts.
6. Using VOM check for voltage across fan terminals DF1 and DF2 on the board. You should read line voltage (208-230 VAC) indicating the relay is open in the defrost mode.
7. Using VOM check for voltage across "W2" (W on PCBDM133) & "C" terminals on the board. You should read 24 volts.
8. If not as above, replace control board.
9. Set thermostat to off position and disconnect power before removing any jumpers or wires.

NOTE: Remove jumper across defrost thermostat before returning system to service.

S-25 TESTING DEFROST THERMOSTAT

1. Install a thermocouple type temperature test lead on the tube adjacent to the defrost control. Insulate the lead point of contact.
2. Check the temperature at which the control closes its contacts by lowering the temperature of the control. It should close at approximately $32^{\circ}\text{F} \pm 2^{\circ}\text{F}$.
3. Check the temperature at which the control opens its contacts by raising the temperature of the control. It should open at approximately 60°F .
4. If not as above, replace control.

S-50 CHECKING HEATER LIMIT CONTROL(S)

(OPTIONAL ELECTRIC HEATERS)

Each individual heater element is protected with an automatic rest limit control connected in series with each element to prevent overheating of components in case of low airflow. This limit control will open its circuit at approximately 150°F . to 160°F and close at approximately 110°F .



DISCONNECT ELECTRICAL POWER SUPPLY.

1. Remove the wiring from the control terminals.
2. Using an ohmmeter test for continuity across the normally closed contacts. No reading indicates the control is open - replace if necessary. Make sure the limits are cool before testing.

IF FOUND OPEN - REPLACE - DO NOT WIRE AROUND.

S-52 CHECKING HEATER ELEMENTS

Optional electric heaters may be added, in the quantities shown in the spec sheet for each model unit, to provide electric resistance heating. Under no condition shall more heaters than the quantity shown be installed.



**HIGH VOLTAGE!
DISCONNECT ALL POWER BEFORE
SERVICING OR INSTALLING THIS UNIT.
MULTIPLE POWER SOURCES MAY BE
PRESENT. FAILURE TO DO SO MAY CAUSE PROPERTY
DAMAGE, PERSONAL INJURY OR DEATH.**



1. Disassemble and remove the heating element(s).
2. Visually inspect the heater assembly for any breaks in the wire or broken insulators.
3. Using an ohmmeter, test the element for continuity - no reading indicates the element is open. Replace as necessary.

SERVICING

S-100 REFRIGERATION REPAIR PRACTICE



ALWAYS REMOVE THE REFRIGERANT CHARGE IN A PROPER MANNER BEFORE APPLYING HEAT TO THE SYSTEM.

These models use the FasTest Access Fitting System, with a saddle that is either soldered to the suction and liquid lines or is fastened with a locking nut to the access fitting box (core) and then screwed into the saddle. **Do not remove the core from the saddle until the refrigerant charge has been removed. Failure to do so could result in property damage or personal injury.**

When installing a new core or reinstalling the core after removal, it is very important to note that before inserting the core into the saddle, the core and saddle must be free of debris and the "O" Ring **must** have a thin coating of refrigerant oil applied to it. The oil is to prevent the "O" Ring from being deformed when the core is tightened completely. The core should be torqued to 8 ft. lb.

When repairing the refrigeration system:



DISCONNECT ELECTRICAL POWER SUPPLY.

1. Never open a system that is under vacuum. Air and moisture will be drawn in.
2. Plug or cap all openings.
3. Remove all burrs and clean the brazing surfaces of the tubing with sand cloth or paper. Brazing materials do not flow well on oxidized or oily surfaces.
4. Clean the inside of all new tubing to remove oils and pipe chips.
5. When brazing, sweep the tubing with dry nitrogen to prevent the formation of oxides on the inside surfaces.
6. Complete any repair by replacing the liquid line drier in the system, evacuate and charge.

At any time the system has been open for repair, the factory installed liquid line filter drier **must** be replaced.

BRAZING MATERIALS

Copper to Copper Joints - Sil-Fos used without flux (alloy of 15% silver, 80% copper, and 5% phosphorous). Recommended heat 1400°F.

Copper to Steel Joints - Silver Solder used without a flux (alloy of 30% silver, 38% copper, 32% zinc). Recommended heat - 1200°F.

S-101 LEAK TESTING

(NITROGEN OR NITROGEN-TRACED)



TO AVOID THE RISK OF FIRE OR EXPLOSION, NEVER USE OXYGEN, HIGH PRESSURE AIR OR FLAMMABLE GASES FOR LEAK TESTING OF A REFRIGERATION SYSTEM.



TO AVOID POSSIBLE EXPLOSION, THE LINE FROM THE NITROGEN CYLINDER MUST INCLUDE A PRESSURE REGULATOR AND PRESSURE RELIEF VALVE. THE PRESSURE RELIEF VALVE MUST BE SET TO OPEN AT NO MORE THAN 150 psig.

Pressure test the system using dry nitrogen and soapy water to locate leaks. If you wish to use a leak detector, charge the system to 10 psi using the appropriate refrigerant then use nitrogen to finish charging the system to working pressure, then apply the detector to suspect areas. If leaks are found, repair them. After repair, repeat the pressure test. If no leaks exist, proceed to system evacuation.

For a system that contains a refrigerant charge and is suspected of having a leak, stop the operation and hold the exploring tube of the detector as close to the tube as possible, check all piping and fittings. If a leak is detected, do not attempt to apply more brazing to the joint. Remove and capture the charge, unbrazed the joint, clean and rebraze.

For a system that has been newly repaired and does not contain a charge, connect a cylinder of refrigerant, through a gauge manifold, to the liquid and suction line dill valves and/or liquid line dill valve and compressor process tube.

NOTE: Refrigerant hoses must be equipped with dill valve depressors or special adaptor used. Open the valve on the cylinder and manifold and allow the pressure to build up within the system. Check for and handle leaks, as described above. After the test has been completed, remove and capture the leak test refrigerant.

S-102 EVACUATION



**REFRIGERANT UNDER PRESSURE!
FAILURE TO FOLLOW PROPER PROCEDURES MAY CAUSE PROPERTY DAMAGE, PERSONAL INJURY OR DEATH.**

SERVICING

This is the most important part of the entire service procedure. The life and efficiency of the equipment is dependent upon the thoroughness exercised by the serviceman when evacuating air (non-condensable) and moisture from the system.

Air in a system causes high condensing temperature and pressure, resulting in increased power input and reduced performance.

Moisture chemically reacts with the refrigerant and oil to form corrosive hydrofluoric and hydrochloric acids. These attack motor windings and parts, causing breakdown.

The equipment required to thoroughly evacuate the system is a high vacuum pump, capable of producing a vacuum equivalent to 25 microns absolute and a thermocouple vacuum gauge to give a true reading of the vacuum in the system.

NOTE: Never use the system compressor as a vacuum pump or run when under a high vacuum. Motor damage could occur.

2. Start the vacuum pump and open the shut off valve to the high vacuum gauge manifold only. After the compound gauge (low side) has dropped to approximately 29 inches of vacuum, open the valve to the vacuum thermocouple gauge. See that the vacuum pump will blank-off to a maximum of 25 microns. A high vacuum pump can only produce a good vacuum if its oil is non-contaminated.
3. If the vacuum pump is working properly, close the valve to the vacuum thermocouple gauge and open the high and low side valves to the high vacuum manifold set. With the valve on the charging cylinder closed, open the manifold valve to the cylinder.
4. Evacuate the system to at least 29 inches gauge before opening valve to thermocouple vacuum gauge.
5. Continue to evacuate to a minimum of 250 microns. Close valve to vacuum pump and watch rate of rise. If vacuum does not rise above 1500 microns in three to five minutes, system can be considered properly evacuated.
6. If thermocouple vacuum gauge continues to rise and levels off at about 5000 microns, moisture and non-condensables are still present. If gauge continues to rise a leak is present. Repair and re-evacuate.
7. Close valve to thermocouple vacuum gauge and vacuum pump. Shut off pump and prepare to charge.

WARNING

SCROLL COMPRESSORS
DO NOT FRONT SEAT THE SERVICE VALVE(S) WITH THE COMPRESSOR OPERATING IN AN ATTEMPT TO SAVE REFRIGERANT. WITH THE SUCTION LINE OF THE COMPRESSOR CLOSED OR SEVERLY RESTRICTED, THE SCROLL COMPRESSOR WILL DRAW A DEEP VACUUM VERY QUICKLY. THIS VACUUM CAN CAUSE INTERNAL ARCING OF THE FUSITE RESULTING IN A DAMAGED OR FAILED COMPRESSOR.

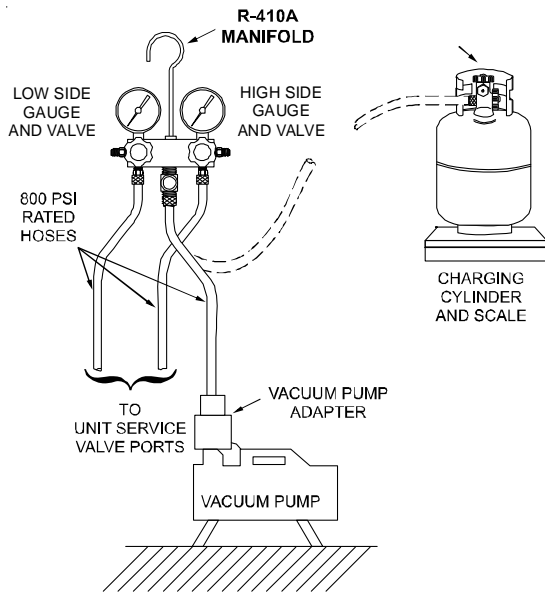

1. Connect the vacuum pump, vacuum tight manifold set with high vacuum hoses, thermocouple vacuum gauge and charging cylinder as shown.

S-103 CHARGING

WARNING

REFRIGERANT UNDER PRESSURE!
- DO NOT OVERCHARGE SYSTEM WITH REFRIGERANT.
- DO NOT OPERATE UNIT IN A VACUUM OR AT NEGATIVE PRESSURE.
FAILURE TO FOLLOW PROPER PROCEDURES MAY CAUSE PROPERTY DAMAGE, PERSONAL INJURY OR DEATH.

CAUTION

ONLY USE REFRIGERANT CERTIFIED TO AHRI STANDARDS. USED REFRIGERANT MAY CAUSE COMPRESSOR DAMAGE. DAIKIN IS NOT RESPONSIBLE FOR DAMAGE OR THE NEED FOR REPAIRS RESULTING FROM THE USE OF UNAPPROVED REFRIGERANT TYPES OR USED OR RECYCLED REFRIGERANT. MOST PORTABLE MACHINES CANNOT CLEAN USED REFRIGERANT TO MEET AHRI STANDARDS.

Charge the system with the exact amount of refrigerant. Refer to the specification section or check the unit nameplates for the correct refrigerant charge.

After completing airflow measurements and adjustments, the unit's refrigerant charge must be checked. The unit comes factory charged, but this charge is based on 400 CFM per ton at minimum ESP per AHRI test conditions (generally between .15 - .25 ESP). When air quantity or ESP is different than above, charge must be adjusted to the proper amount.

SERVICING

All package units are charged to the superheat method at the compressor suction line (these are fixed orifice devices).

For charging in the warmer months, 10°F superheat at the compressor is required at conditions: 95°F outdoor ambient (dry bulb temperature), 80°F dry bulb / 67°F wet bulb indoor ambient, approximately 50% humidity. This superheat varies when conditions vary from the conditions described.

A superheat charge chart is available for other operating conditions. Use it to provide the correct superheat at the conditions the unit is being charged at.

After superheat is adjusted it is recommended to check unit sub-cooling at the condenser coil liquid line out. In most operating conditions 12 ± 4°F of sub-cooling is adequate.

An inaccurately charged system will cause future problems.

1. Using a quality set of charging scales, weigh the proper amount of refrigerant for the system. Allow liquid refrigerant only to enter the high side.
2. After the system will take all it will take, close the valve on the high side of the charging manifold.
3. Start the system and charge the balance of the refrigerant through the low side.

NOTE: R410A should be drawn out of the storage container or drum in liquid form due to its fractionation properties, but should be "Flashed" to its gas state before entering the system. There are commercially available restriction devices that fit into the system charging hose set to accomplish this. **DO NOT** charge liquid R410A into the compressor.

4. With the system still running, close the valve on the charging cylinder. At this time, you may still have some liquid refrigerant in the charging cylinder hose and will definitely have liquid in the liquid hose. Slowly open the high side manifold valve and transfer the liquid refrigerant from the liquid line hose and charging cylinder hose into the suction service valve port. **CAREFUL:** Watch so that liquid refrigerant does not enter the compressor.

Final Charge Adjustment

The outdoor temperature must be 60°F or higher. Set the room thermostat to COOL, fan switch to AUTO, and set the temperature control well below room temperature.

After system has stabilized per start-up instructions, compare the operating pressures and outdoor unit amp draw to the numbers listed in the technical manual. If pressures and amp draw are too low, add charge. If pressures and amp draw are too high, remove charge. Check subcooling and superheat as detailed in the following section.

5. With the system still running, remove hose and reinstall both access fitting caps.
6. Check system for leaks.

Due to their design, Scroll compressors are inherently more tolerant of liquid refrigerant.

NOTE: *Even though the compressor section of a Scroll compressor is more tolerant of liquid refrigerant, continued flood-back or flooded start conditions may wash oil from the bearing surfaces causing premature bearing failure. S-104 CHECKING COMPRESSOR EFFICIENCY.*

The reason for compressor inefficiency is broken or damaged suction and/or discharge valves, or scroll flanks on Scroll compressors, reducing the ability of the compressor to pump refrigerant vapor.

The condition of the valves or scroll flanks is checked in the following manner.

1. Attach gauges to the high and low side of the system.
2. Start the system and run a Cooling Performance Test.

If the test shows-

- ⇒ Below normal high side pressure.
- ⇒ Above normal low side pressure.
- ⇒ Low temperature difference across coil.
- ⇒ Low amp draw at compressor.

-and the charge is correct. The compressor is faulty - replace the compressor.

S-104 CHECKING COMPRESSOR EFFICIENCY

The reason for compressor inefficiency is broken or damaged suction and/or discharge valves, or scroll flanks on Scroll compressors, reducing the ability of the compressor to pump refrigerant vapor.

During the "OFF" cycle, the high side pressure bleeds to the low side through the fixed orifice restriction device. Check equalization time as follows:

1. Attach a gauge manifold to the suction and liquid line access fittings.
2. Start the system and allow the pressures to stabilize.
3. Stop the system and check the time it takes for the high and low pressure gauge readings to equalize.

If it takes more than seven (7) minutes to equalize, the restrictor device is inoperative. Replace, install a liquid line drier, evacuate and recharge.

S-108 SUPERHEAT

CHECKING SUPERHEAT

Refrigerant gas is considered superheated whenever its temperature is higher than the saturation temperature corresponding to its pressure. The degree of superheat equals the degrees of temperature increase above the saturation temperature at existing pressure. See Temperature - Pressure Chart.

SERVICING



CAUTION

To prevent personal injury, carefully connect and disconnect manifold gauge hoses. Escaping liquid refrigerant can cause burns. Do not vent refrigerant to atmosphere. Recover during system repair or final unit disposal.

1. Run system at least 10 minutes to allow pressure to stabilize.
2. Temporarily install thermometer on suction (large) line near compressor with adequate contact and insulate for best possible reading.
3. Refer to the superheat table provided for proper system superheat. Add charge to lower superheat or recover charge to raise superheat.

Superheat Formula = Suct. Line Temp. - Sat. Suct. Temp.

Ambient Condenser Inlet Temp (°F Drybulb)	Return Air Temp. (°F Drybulb)				
	65	70	75	80	85
100	-	-	-	10	10
95	-	-	10	10	10
90	-	-	12	15	18
85	-	10	13	17	20
80	-	10	15	21	26
75	10	13	17	25	29
70	10	17	20	28	32
65	13	19	26	32	35
60	17	25	30	33	37

EXAMPLE:

- a. Suction Pressure = 143
- b. Corresponding Temp. °F. = 50
- c. Thermometer on Suction Line = 59°F.

To obtain the degrees temperature of superheat, subtract 50.0 from 59.0°F.

The difference is 9° Superheat. The 9° Superheat would fall in the ± range of allowable superheat.

S-109 CHECKING SUBCOOLING

Refrigerant liquid is considered subcooled when its temperature is lower than the saturation temperature corresponding to its pressure. The degree of subcooling equals the degrees of temperature decrease below the saturation temperature at the existing pressure.

1. Attach an accurate thermometer or preferably a thermocouple type temperature tester to the liquid line close to the pressure switch.
2. Install a high side pressure gauge on the liquid access fitting.
3. Record the gauge pressure and the temperature of the line.
4. Compare the hi-pressure reading to the "Required Liquid

Line Temperature" chart. Find the hi-pressure value on the left column. Follow that line right to the column under the design subcooling value. Where the two intersect is the required liquid line temperature.

Alternately you can convert the liquid line pressure gauge reading to temperature by finding the gauge reading in Temperature - Pressure Chart and reading to the left, find the temperature in the °F. Column.

5. The difference between the thermometer reading and pressure to temperature conversion is the amount of subcooling.

Subcooling Formula = Sat. Liquid Temp. - Liquid Line Temp.

EXAMPLE:

- a. Liquid Line Pressure = 417
- b. Corresponding Temp. °F. = 120°
- c. Thermometer on Liquid line = 109°F.

To obtain the amount of subcooling, subtract 109°F from 120°F.

The difference is 11° subcooling. See the specification sheet or technical information manual for the design subcooling range for your unit.

See R410A Pressure vs. Temperature chart.

S-111 FIXED ORIFICE RESTRICTION DEVICES

The fixed orifice restriction device (flowrator) used in conjunction with the indoor coil is a predetermined bore (I.D.).

It is designed to control the rate of liquid refrigerant flow into an evaporator coil.

The amount of refrigerant that flows through the fixed orifice restriction device is regulated by the pressure difference between the high and low sides of the system.

In the cooling cycle when the outdoor air temperature rises, the high side condensing pressure rises. At the same time, the cooling load on the indoor coil increases, causing the low side pressure to rise, but at a slower rate.

Since the high side pressure rises faster when the temperature increases, more refrigerant flows to the evaporator, increasing the cooling capacity of the system.

When the outdoor temperature falls, the reverse takes place. The condensing pressure falls, and the cooling loads on the indoor coil decreases, causing less refrigerant flow.

If a restriction should become evident, proceed as follows:

1. Recover refrigerant charge.
2. Remove the orifice assembly and clean or replace.
3. Replace liquid line drier, evacuate and recharge.

SERVICING

CHECKING EQUALIZATION TIME

During the "OFF" cycle, the high side pressure bleeds to the low side through the fixed orifice restriction device. Check equalization time as follows:

1. Attach a gauge manifold to the suction and liquid line dill valves
2. Start the system and allow the pressures to stabilize.
3. Stop the system and check the time it takes for the high and low pressure gauge readings to equalize.

If it takes more than seven (7) minutes to equalize, the restriction device is inoperative. Replace, install a liquid line drier, evacuate and recharge.

S-112 CHECKING RESTRICTED LIQUID LINE

When the system is operating, the liquid line is warm to the touch. If the liquid line is restricted, a definite temperature drop will be noticed at the point of restriction. In severe cases, frost will form at the restriction and extend down the line in the direction of the flow.

Discharge and suction pressures will be low, giving the appearance of an undercharged unit. However, the unit will have normal to high subcooling.

If a restriction is located, replace the restricted part, replace drier, evacuate and recharge.

S-113 REFRIGERANT OVERCHARGE

An overcharge of refrigerant is normally indicated by an excessively high head pressure.

An evaporator coil, using an expansion valve metering device, will basically modulate and control a flooded evaporator and prevent liquid refrigerant from returning to the compressor.

An evaporator coil, using a fixed orifice restrictor device (flowrator) metering device, could allow liquid refrigerant to return to the compressor under extreme overcharge conditions.

Also with a fixed orifice restrictor device (flowrator) metering device, extreme cases of insufficient indoor air can cause icing of the indoor coil and liquid refrigerant to return to the compressor, but the head pressure would be lower.

There are other causes for high head pressure which may be found in the "Service Problem Analysis Guide."

If other causes check out normal, an overcharge or a system containing non-condensables would be indicated.

If this system is observed:

1. Start the system.
2. Remove and capture small quantities of refrigerant as from the suction line access fitting until the head pressure is reduced to normal.
3. Observe the system while running a cooling performance test. If a shortage of refrigerant is indicated, then the system contains non-condensables.

S-114 NON-CONDENSABLES

If non-condensables are suspected, shut down the system and allow the pressures to equalize. Wait at least 15 minutes. Compare the pressure to the temperature of the coldest coil since this is where most of the refrigerant will be. If the pressure indicates a higher temperature than that of the coil temperature, non-condensables are present.

Non-condensables are removed from the system by first removing the refrigerant charge, replacing and/or installing liquid line drier, evacuating and recharging.

SERVICING

Pressure vs. Temperature Chart													
R-410A													
PSIG	°F	PSIG	°F	PSIG	°F	PSIG	°F	PSIG	°F	PSIG	°F	PSIG	°F
12	-37.7	114.0	37.8	216.0	74.3	318.0	100.2	420.0	120.7	522.0	137.6		
14	-34.7	116.0	38.7	218.0	74.9	320.0	100.7	422.0	121.0	524.0	137.9		
16	-32.0	118.0	39.5	220.0	75.5	322.0	101.1	424.0	121.4	526.0	138.3		
18	-29.4	120.0	40.5	222.0	76.1	324.0	101.6	426.0	121.7	528.0	138.6		
20	-36.9	122.0	41.3	224.0	76.7	326.0	102.0	428.0	122.1	530.0	138.9		
22	-24.5	124.0	42.2	226.0	77.2	328.0	102.4	430.0	122.5	532.0	139.2		
24	-22.2	126.0	43.0	228.0	77.8	330.0	102.9	432.0	122.8	534.0	139.5		
26	-20.0	128.0	43.8	230.0	78.4	332.0	103.3	434.0	123.2	536.0	139.8		
28	-17.9	130.0	44.7	232.0	78.9	334.0	103.7	436.0	123.5	538.0	140.1		
30	-15.8	132.0	45.5	234.0	79.5	336.0	104.2	438.0	123.9	540.0	140.4		
32	-13.8	134.0	46.3	236.0	80.0	338.0	104.6	440.0	124.2	544.0	141.0		
34	-11.9	136.0	47.1	238.0	80.6	340.0	105.1	442.0	124.6	548.0	141.6		
36	-10.1	138.0	47.9	240.0	81.1	342.0	105.4	444.0	124.9	552.0	142.1		
38	-8.3	140.0	48.7	242.0	81.6	344.0	105.8	446.0	125.3	556.0	142.7		
40	-6.5	142.0	49.5	244.0	82.2	346.0	106.3	448.0	125.6	560.0	143.3		
42	-4.5	144.0	50.3	246.0	82.7	348.0	106.6	450.0	126.0	564.0	143.9		
44	-3.2	146.0	51.1	248.0	83.3	350.0	107.1	452.0	126.3	568.0	144.5		
46	-1.6	148.0	51.8	250.0	83.8	352.0	107.5	454.0	126.6	572.0	145.0		
48	0.0	150.0	52.5	252.0	84.3	354.0	107.9	456.0	127.0	576.0	145.6		
50	1.5	152.0	53.3	254.0	84.8	356.0	108.3	458.0	127.3	580.0	146.2		
52	3.0	154.0	54.0	256.0	85.4	358.0	108.8	460.0	127.7	584.0	146.7		
54	4.5	156.0	54.8	258.0	85.9	360.0	109.2	462.0	128.0	588.0	147.3		
56	5.9	158.0	55.5	260.0	86.4	362.0	109.6	464.0	128.3	592.0	147.9		
58	7.3	160.0	56.2	262.0	86.9	364.0	110.0	466.0	128.7	596.0	148.4		
60	8.6	162.0	57.0	264.0	87.4	366.0	110.4	468.0	129.0	600.0	149.0		
62	10.0	164.0	57.7	266.0	87.9	368.0	110.8	470.0	129.3	604.0	149.5		
64	11.3	166.0	58.4	268.0	88.4	370.0	111.2	472.0	129.7	608.0	150.1		
66	12.6	168.0	59.0	270.0	88.9	372.0	111.6	474.0	130.0	612.0	150.6		
68	13.8	170.0	59.8	272.0	89.4	374.0	112.0	476.0	130.3	616.0	151.2		
70	15.1	172.0	60.5	274.0	89.9	376.0	112.4	478.0	130.7	620.0	151.7		
72	16.3	174.0	61.1	276.0	90.4	378.0	112.6	480.0	131.0	624.0	152.3		
74	17.5	176.0	61.8	278.0	90.9	380.0	113.1	482.0	131.3	628.0	152.8		
76	18.7	178.0	62.5	280.0	91.4	382.0	113.5	484.0	131.6	632.0	153.4		
78	19.8	180.0	63.1	282.0	91.9	384.0	113.9	486.0	132.0	636.0	153.9		
80	21.0	182.0	63.8	284.0	92.4	386.0	114.3	488.0	132.3	640.0	154.5		
82	22.1	184.0	64.5	286.0	92.8	388.0	114.7	490.0	132.6	644.0	155.0		
84	23.2	186.0	65.1	288.0	93.3	390.0	115.0	492.0	132.9	648.0	155.5		
86	24.3	188.0	65.8	290.0	93.8	392.0	115.5	494.0	133.3	652.0	156.1		
88	25.4	190.0	66.4	292.0	94.3	394.0	115.8	496.0	133.6	656.0	156.6		
90	26.4	192.0	67.0	294.0	94.8	396.0	116.2	498.0	133.9	660.0	157.1		
92	27.4	194.0	67.7	296.0	95.2	398.0	116.6	500.0	134.0	664.0	157.7		
94	28.5	196.0	68.3	298.0	95.7	400.0	117.0	502.0	134.5	668.0	158.2		
96	29.5	198.0	68.9	300.0	96.2	402.0	117.3	504.0	134.8	672.0	158.7		
98	30.5	200.0	69.5	302.0	96.6	404.0	117.7	506.0	135.2	676.0	159.2		
100	31.2	202.0	70.1	304.0	97.1	406.0	118.1	508.0	135.5	680.0	159.8		
102	32.2	204.0	70.7	306.0	97.5	408.0	118.5	510.0	135.8	684.0	160.3		
104	33.2	206.0	71.4	308.0	98.0	410.0	118.8	512.0	136.1	688.0	160.8		
106	34.1	208.0	72.0	310.0	98.4	412.0	119.2	514.0	136.4	692.0	161.3		
108	35.1	210.0	72.6	312.0	98.9	414.0	119.6	516.0	136.7	696.0	161.8		
110	35.5	212.0	73.2	314.0	99.3	416.0	119.9	518.0	137.0				
112	36.9	214.0	73.8	316.0	99.7	418.0	120.3	520.0	137.3				

*Based on ALLIED SIGNAL Data

SERVICING

REQUIRED LIQUID LINE TEMPERATURE						
LIQUID PRESSURE AT ACCESS FITTING (PSIG)	REQUIRED SUBCOOLING TEMPERATURE (°F)					
	8	10	12	14	16	18
189	58	56	54	52	50	48
195	60	58	56	54	52	50
202	62	60	58	56	54	52
208	64	62	60	58	56	54
215	66	64	62	60	58	56
222	68	66	64	62	60	58
229	70	68	66	64	62	60
236	72	70	68	66	64	62
243	74	72	70	68	66	64
251	76	74	72	70	68	66
259	78	76	74	72	70	68
266	80	78	76	74	72	70
274	82	80	78	76	74	72
283	84	82	80	78	76	74
291	86	84	82	80	78	76
299	88	86	84	82	80	78
308	90	88	86	84	82	80
317	92	90	88	86	84	82
326	94	92	90	88	86	84
335	96	94	92	90	88	86
345	98	96	94	92	90	88
354	100	98	96	94	92	90
364	102	100	98	96	94	92
374	104	102	100	98	96	94
384	106	104	102	100	98	96
395	108	106	104	102	100	98
406	110	108	106	104	102	100
416	112	110	108	106	104	102
427	114	112	110	108	106	104
439	116	114	112	110	108	106
450	118	116	114	112	110	108
462	120	118	116	114	112	110
474	122	120	118	116	114	112
486	124	122	120	118	116	114
499	126	124	122	120	118	116
511	128	126	124	122	120	118

SERVICING

S-115 COMPRESSOR BURNOUT

When a compressor burns out, high temperature develops causing the refrigerant, oil and motor insulation to decompose forming acids and sludge.

If a compressor is suspected of being burned-out, attach a refrigerant hose to the liquid line dill valve and properly remove and dispose of the refrigerant.

**NOTICE**

VIOLATION OF EPA REGULATIONS MAY RESULT IN FINES OR OTHER PENALTIES.

Now determine if a burn out has actually occurred. Confirm by analyzing an oil sample using a Sporlan Acid Test Kit, AK-3 or its equivalent.

Remove the compressor and obtain an oil sample from the suction stub. If the oil is not acidic, either a burnout has not occurred or the burnout is so mild that a complete clean-up is not necessary.

If acid level is unacceptable, the system must be cleaned by using the clean-up drier method.

**CAUTION**

DO NOT ALLOW THE SLUDGE OR OIL TO CONTACT THE SKIN, SEVERE BURNS MAY RESULT.

NOTE: Daikin does **NOT** approve the flushing method using R-11 refrigerant.

Suction Line Drier Clean-Up Method

The POE oils used with R410A refrigerant is an excellent solvent. In the case of a burnout, the POE oils will remove any burnout residue left in the system. If not captured by the refrigerant filter, they will collect in the compressor or other system components, causing a failure of the replacement compressor and/or spread contaminants throughout the system, damaging additional components.

Install a suction line filter drier. This drier should be installed as close to the compressor suction fitting as possible. The filter must be accessible and be rechecked for a pressure drop after the system has operated for a time. It may be necessary to use new tubing and form as required.

NOTE: At least twelve (12) inches of the suction line immediately out of the compressor stub must be discarded due to burned residue and contaminates.

1. Remove the liquid line drier and expansion valve.
2. Purge all remaining components with dry nitrogen or carbon dioxide until clean.
3. Install new components **including** liquid line drier.

4. Braze all joints, leak test, evacuate, and recharge system.
5. Start up the unit and record the pressure drop across the drier.
6. Continue to run the system for a minimum of twelve (12) hours and recheck the pressure drop across the drier. Pressure drop should not exceed 6 PSIG.
7. Continue to run the system for several days, repeatedly checking pressure drop across the suction line drier. If the pressure drop never exceeds the 6 PSIG, the drier has trapped the contaminants. Remove the suction line drier from the system.
8. If the pressure drop becomes greater, then it must be replaced and steps 5 through 9 repeated until it does not exceed 6 PSIG.

NOTICE: Regardless, the cause for burnout must be determined and corrected before the new compressor is started.

S-122 REVERSING VALVE REPLACEMENT

Remove the refrigerant charge from the system.

When brazing a reversing valve into the system, it is of extreme importance that the temperature of the valve **does not exceed 250°F** at any time.

Wrap the reversing valve with a large rag saturated with water. "Re-wet" the rag and thoroughly cool the valve after each brazing operation of the four joints involved. The wet rag around the reversing valve will eliminate conduction of heat to the valve body when brazing the line connection.

The use of a wet rag sometimes can be a nuisance. There are commercial grades of heat absorbing paste that may be substituted.

After the valve has been installed, leak test, evacuate and recharge.

SERVICING

S-200 CHECKING EXTERNAL STATIC PRESSURE

The minimum and maximum allowable duct static pressure is found in the Technical Information Manual.

Too great of an external static pressure will result in insufficient air that can cause icing of the coil, whereas too much air can cause poor humidity control, and condensate to be pulled off the evaporator coil causing condensate leakage. Too much air can cause motor overloading and in many cases this constitutes a poorly designed system. To determine proper air movement, proceed as follows:

1. Using a draft gauge (inclined manometer) measure the static pressure of the return duct at the inlet of the unit, (Negative Pressure).

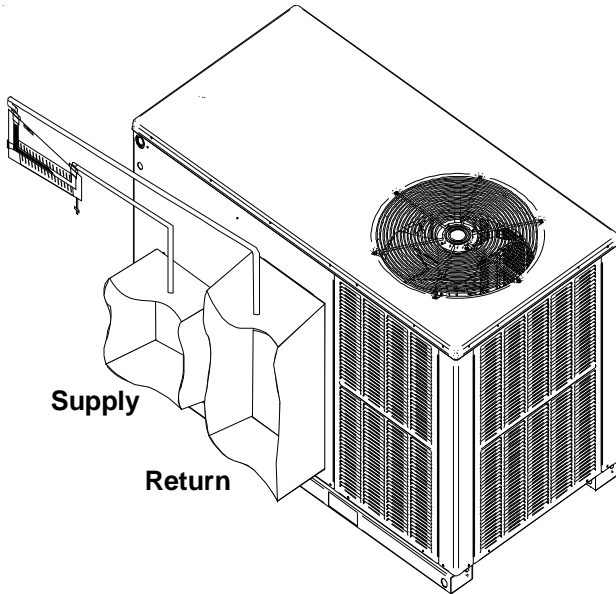

Total External Static

2. Measure the static pressure of the supply duct, (Positive Pressure).
3. Add the two readings together.

NOTE: Both readings may be taken simultaneously and read directly on the manometer as shown in the illustration above, if so desired.

4. Consult proper table for quantity of air.

If the external static pressure exceeds the minimum or maximum allowable statics, check for closed dampers, dirty filters, undersized or poorly laid out ductwork.

S-201 CHECKING TEMPERATURE RISE

Temperature rise is related to the BTUH output of the unit and the amount of air (CFM) circulated over the indoor coil.

All units are designed for a given range of temperature increase. This is the temperature of the air leaving the unit minus the temperature of the air entering the unit.

The more air (CFM) being delivered through a given unit the less the rise will be; so the less air (CFM) being delivered, the greater the rise. The temperature rise should be adjusted in accordance to a given unit specifications and its external static pressure.

1. Take entering and leaving air temperatures.
2. Select the proper speed tap from the unit's blower performance data in the Technical Manual for the specific unit.
3. Take motor amperage draw to determine that the motor is not overloaded during adjustments.

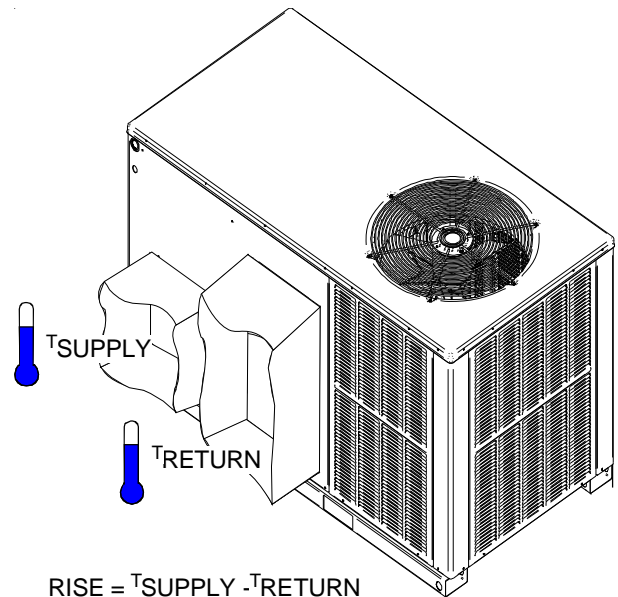

$$\text{RISE} = T_{\text{SUPPLY}} - T_{\text{RETURN}}$$

Checking Temperature Rise

WIRING DIAGRAMS

HIGH VOLTAGE!
 DISCONNECT ALL POWER BEFORE SERVICING OR INSTALLING THIS UNIT. MULTIPLE POWER SOURCES MAY BE PRESENT. FAILURE TO DO SO MAY CAUSE PROPERTY DAMAGE, PERSONAL INJURY OR DEATH.
WARNING

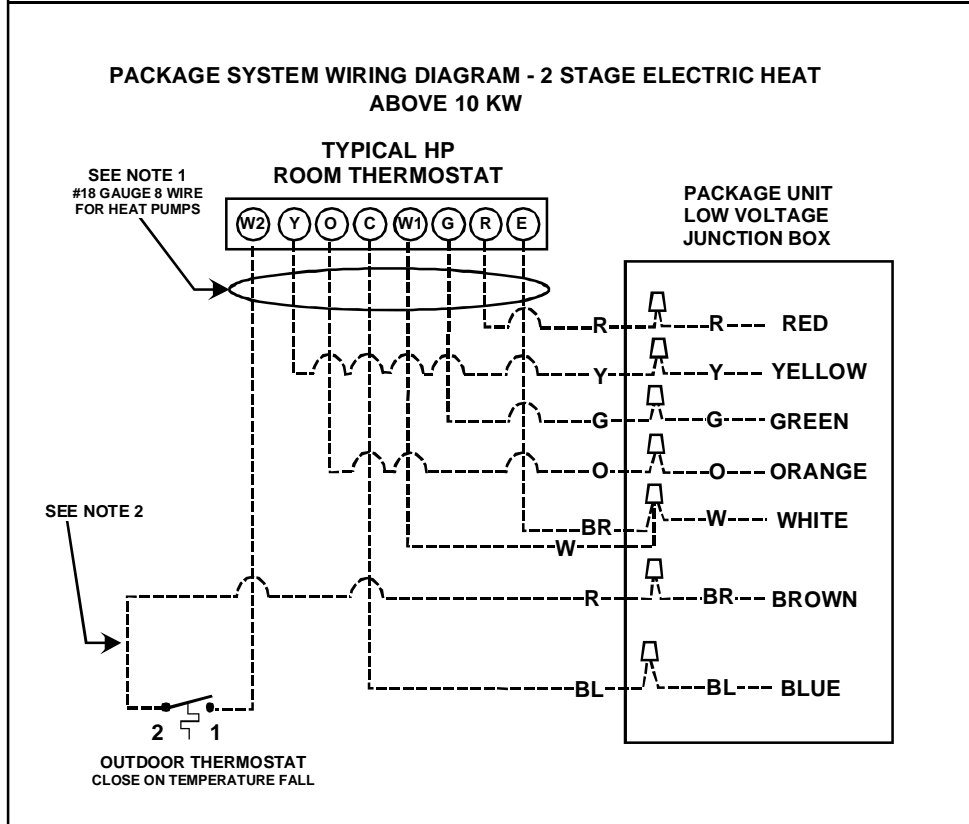
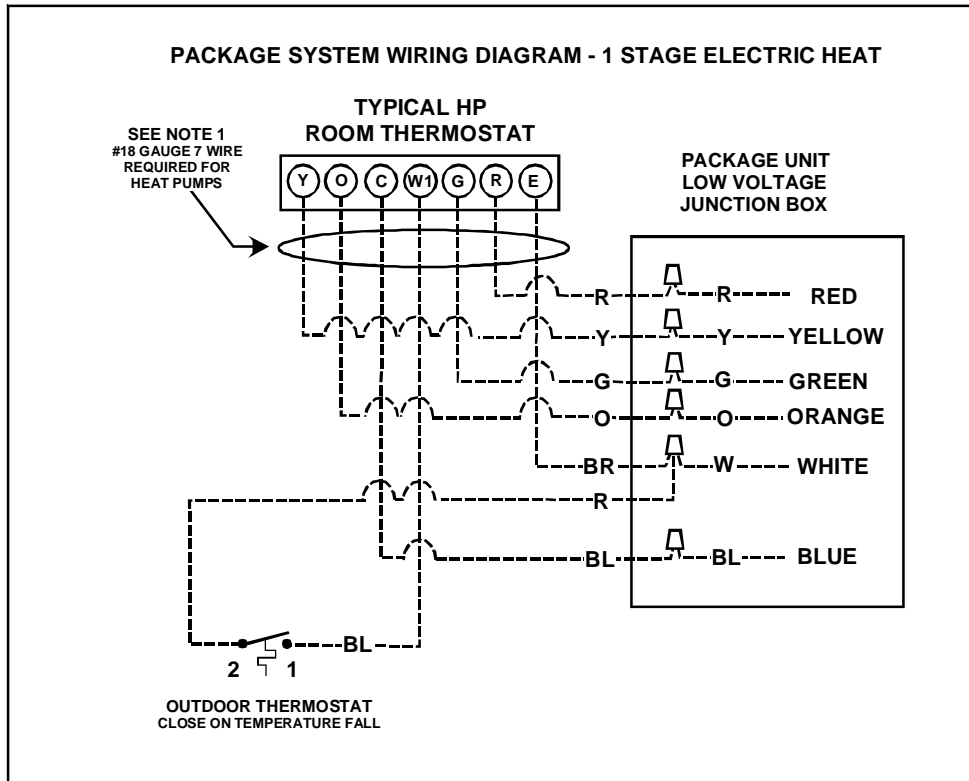

NOTES:

- 1) "O" and "E" used on heat pumps only.
- 2) Connect wire from terminal #1 on outdoor thermostat to the white wire on package units if single stage indoor thermostat is used.

Color Codes
 R - Red
 Y - Yellow
 BL - Blue
 BR - Brown
 O - Orange
 W - White
 G - Green

OT18-60A OUTDOOR THERMOSTAT

Wiring is subject to change. Always refer to the wiring diagram on the unit for the most up-to-date wiring.

WIRING DIAGRAMS

PACKAGE SYSTEM WIRING DIAGRAM - HEAT PUMPS ONLY! TWO-STAGE ELECTRIC HEAT ABOVE 10 kW

TYPICAL H/P ROOM THERMOSTAT

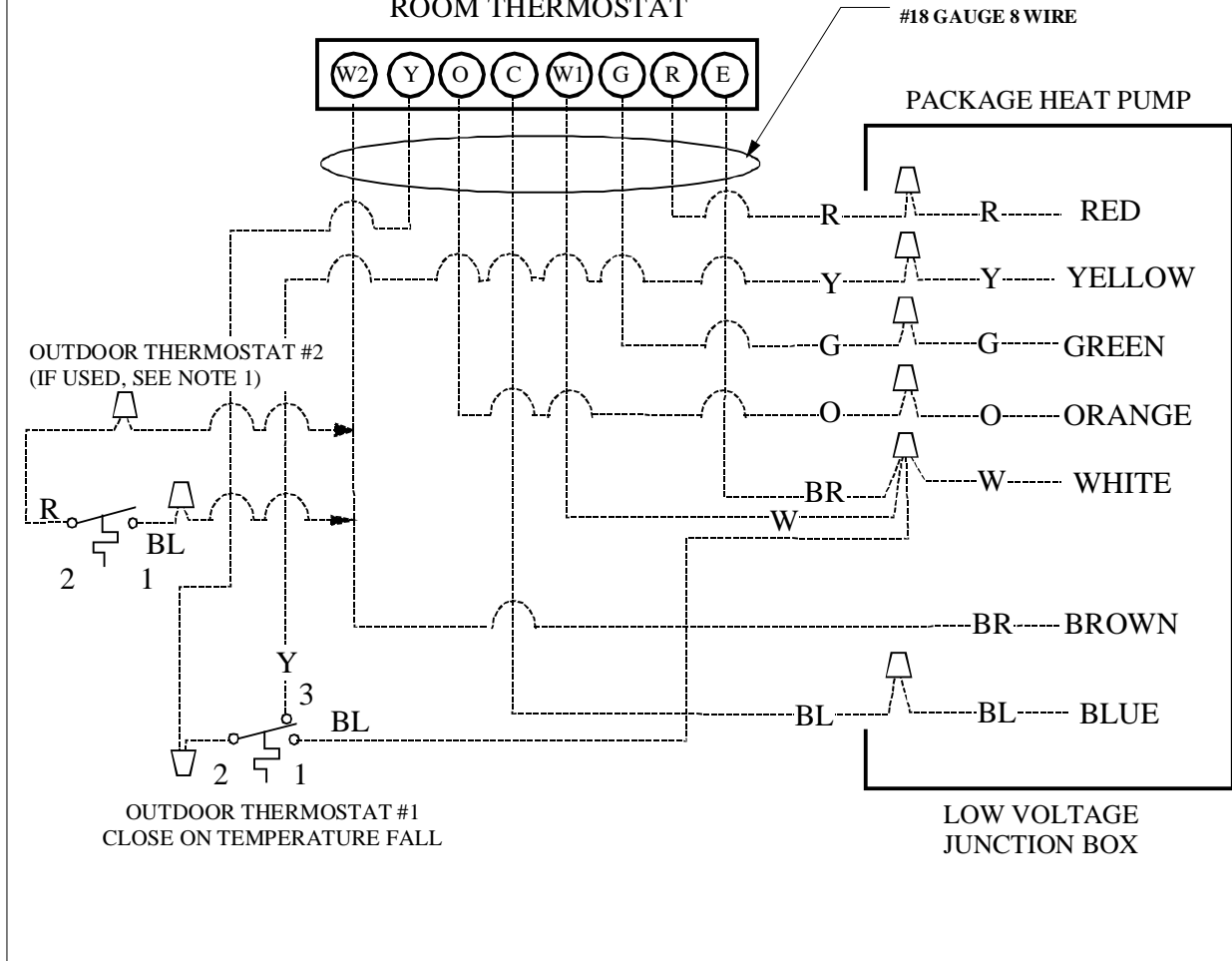

For outdoor temperatures below 0° F with 50% or higher relative humidity, set outdoor thermostat at 0° F

NOTE 1: OT18 #2 CAN BE CONNECTED BETWEEN W2 OF THERMOSTAT AND BROWN WIRE IF DESIRED.

COLOR CODES

R --RED
Y --YELLOW
BL-BLUE
BR-BROWN
O --ORANGE
W -WHITE
G --GREEN

HIGH VOLTAGE!
 DISCONNECT ALL POWER BEFORE SERVICING OR INSTALLING THIS UNIT. MULTIPLE POWER SOURCES MAY BE PRESENT. FAILURE TO DO SO MAY CAUSE PROPERTY DAMAGE, PERSONAL INJURY OR DEATH.
WARNING

OT18-60A OUTDOOR THERMOSTAT

Wiring is subject to change. Always refer to the wiring diagram on the unit for the most up-to-date wiring.

WIRING DIAGRAMS

DP[13-14]CH/HH**41*

HIGH VOLTAGE!
 DISCONNECT ALL POWER BEFORE SERVICING OR INSTALLING THIS UNIT. MULTIPLE POWER SOURCES MAY BE PRESENT. FAILURE TO DO SO MAY CAUSE PROPERTY DAMAGE, PERSONAL INJURY OR DEATH.

WARNING

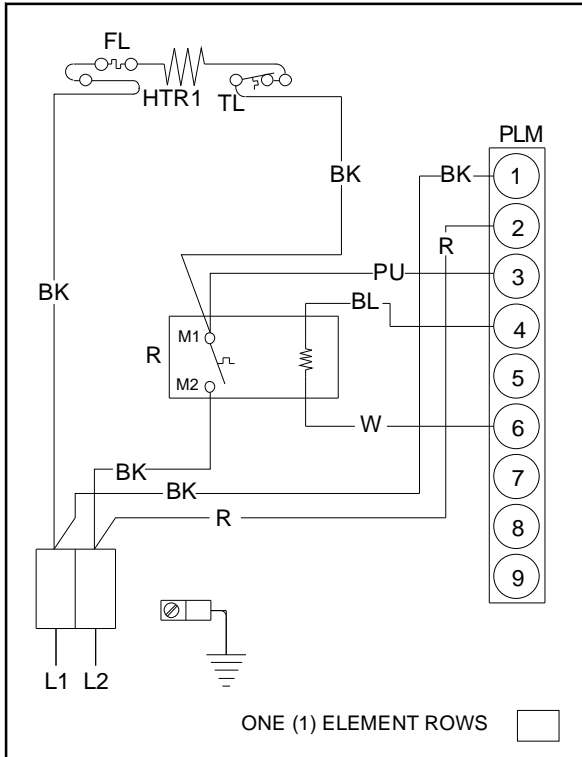

5 KW

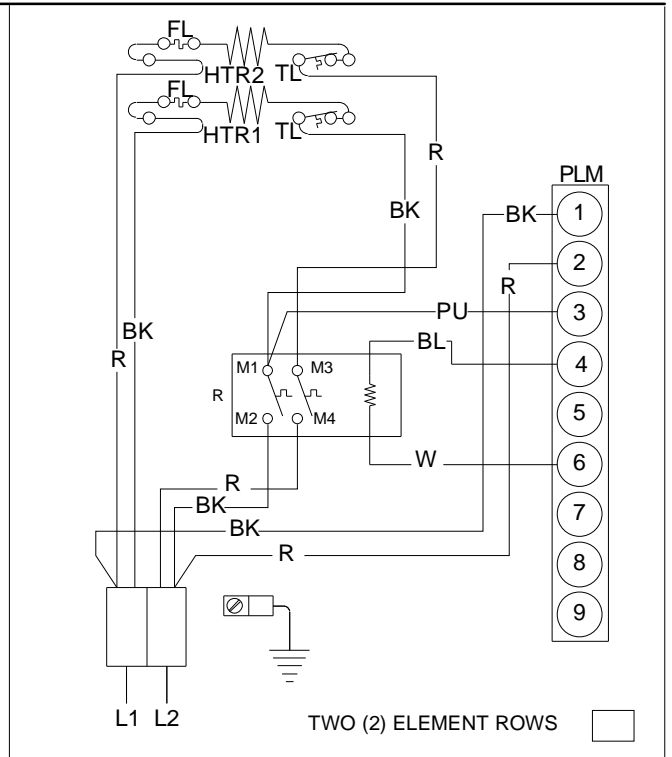

10 KW

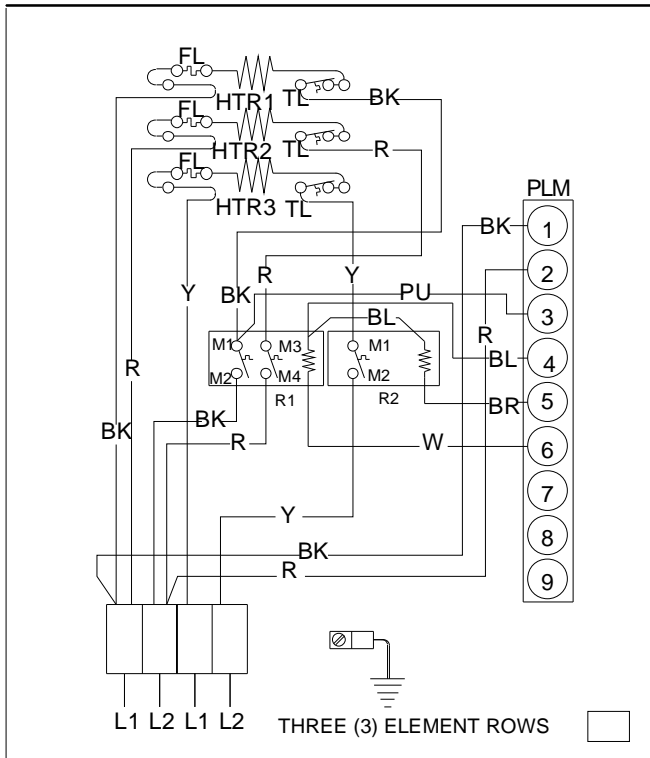

15 KW

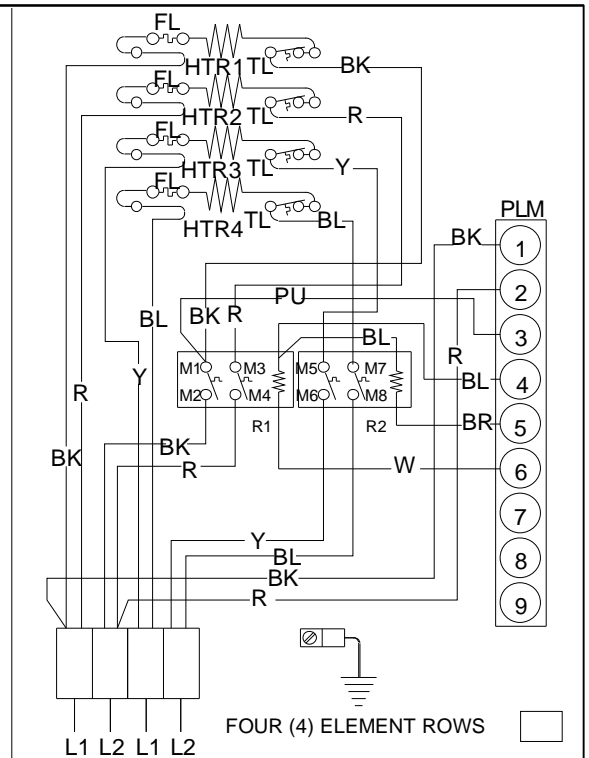

20 KW

SINGLE PHASE HKR/HKP HEAT KIT

Wiring is subject to change. Always refer to the wiring diagram on the unit for the most up-to-date wiring.

WARNING

HIGH VOLTAGE!
DISCONNECT ALL POWER BEFORE SERVICING OR INSTALLING THIS UNIT. MULTIPLE POWER SOURCES MAY BE PRESENT. FAILURE TO DO SO MAY CAUSE PROPERTY DAMAGE, PERSONAL INJURY OR DEATH.

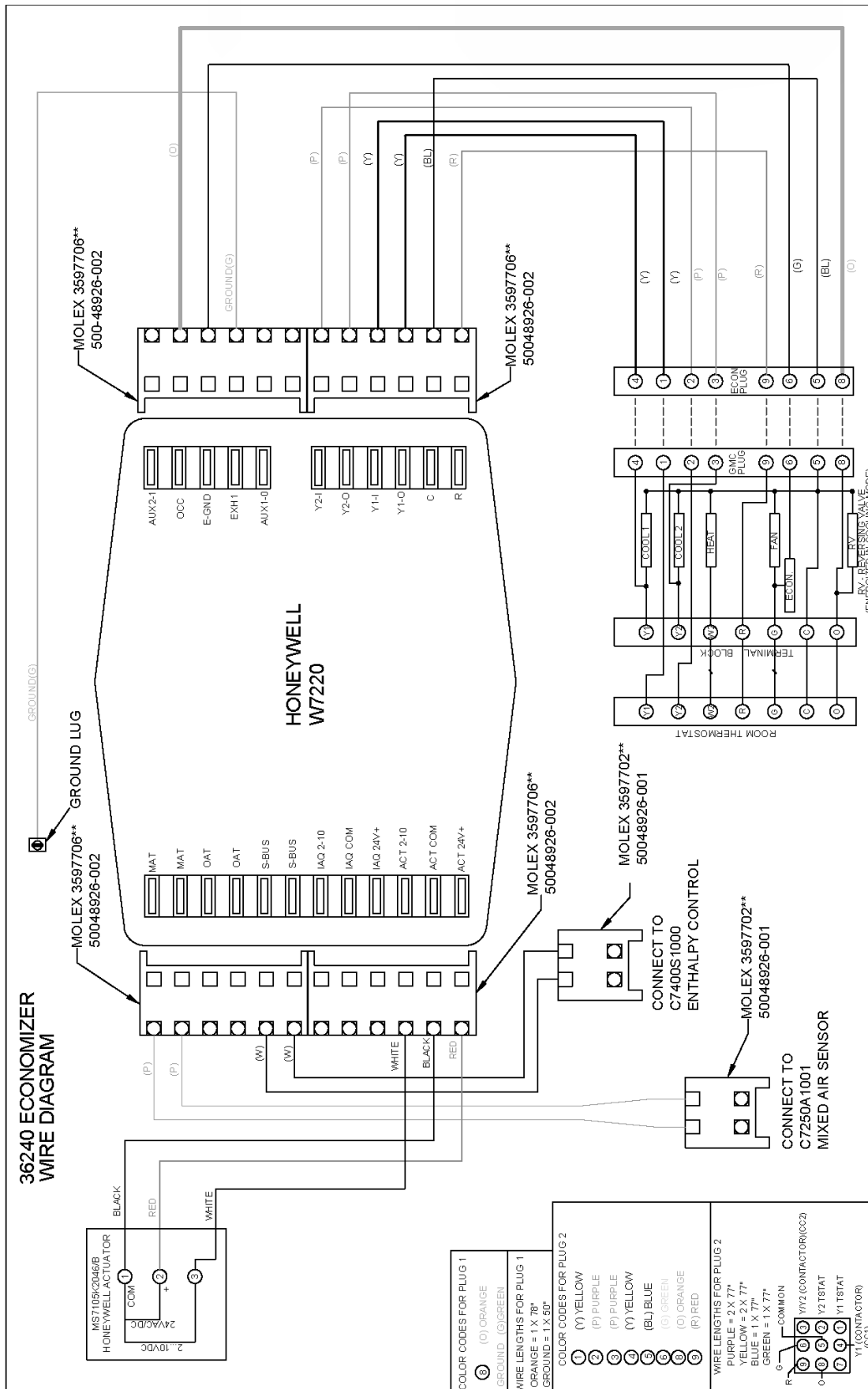

ECONOMIZER FOR DP[13-14]CH/HH41***

Wiring is subject to change. Always refer to the wiring diagram on the unit for the most up-to-date wiring.

HIGH VOLTAGE!
DISCONNECT ALL POWER BEFORE SERVICING OR INSTALLING THIS UNIT. MULTIPLE POWER SOURCES MAY BE PRESENT. FAILURE TO DO SO MAY CAUSE PROPERTY DAMAGE, PERSONAL INJURY OR DEATH.
WARNING

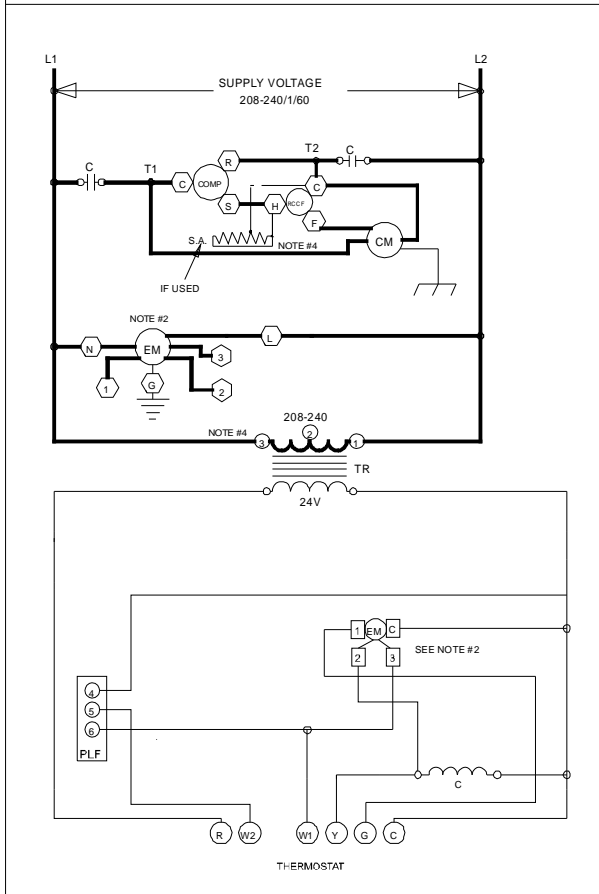
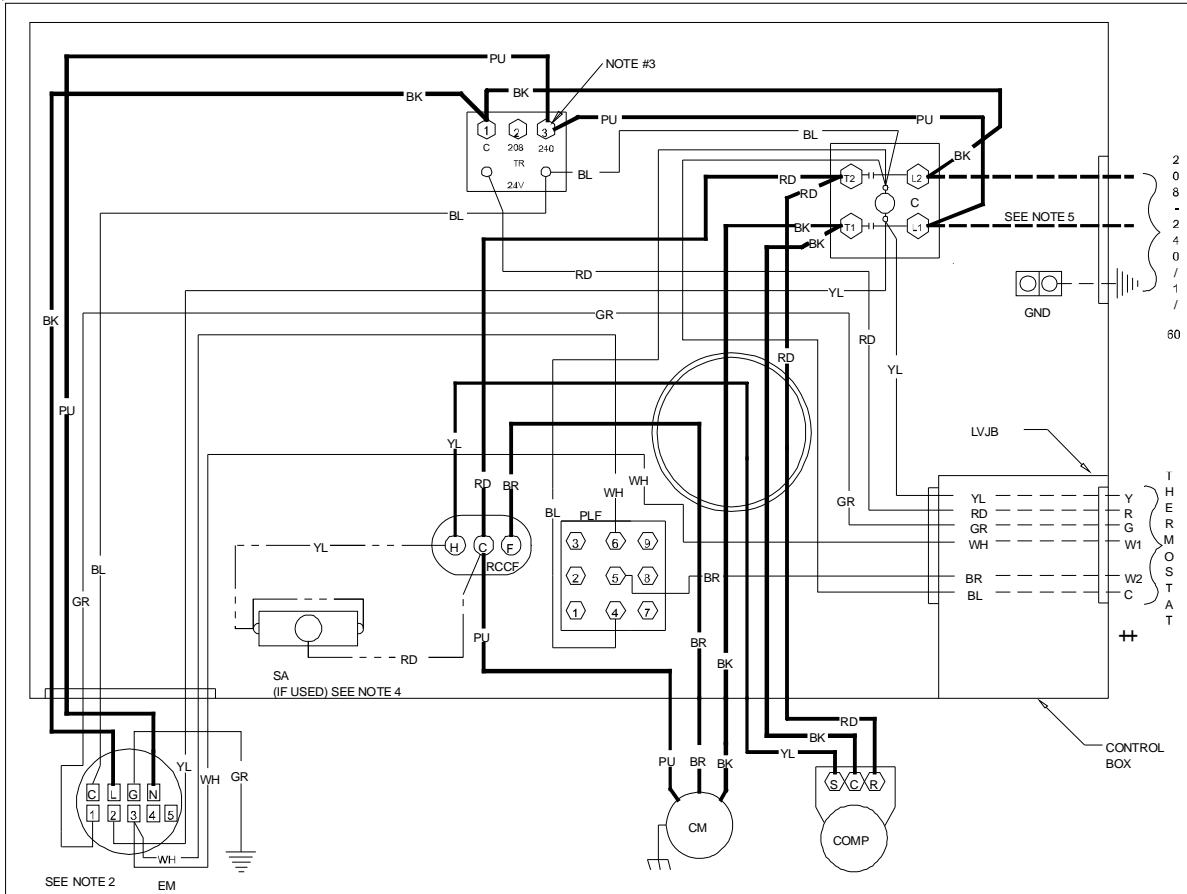

COMPONENT LEGEND		FACTORY WIRING	
C	CONTACTOR		LINE VOLTAGE
CM	CONDENSER MOTOR		LOW VOLTAGE
COMP	COMPRESSOR		OPTIONAL HIGH VOLTAGE
EM	EVAPORATOR MOTOR		FIELD WIRING
GND	EQUIPMENT GROUND		HIGH VOLTAGE
LVJB	LOW VOLTAGE JUNCTION BOX		LOW VOLTAGE
PLF	FEMALE PLUG / CONNECTOR		
RCCF	RUN CAPACITOR FOR J COMPRESSOR AND FAN		
SA	START ASSIST		
TR	TRANSFORMER		

WIRE CODE	
BK	BLACK
BL	BLUE
BR	BROWN
GR	GREEN
OR	ORANGE
PU	PURPLE
RD	RED
WH	WHITE
YL	YELLOW

- NOTES:
- REPLACEMENT WIRE MUST BE SAME SIZE AND TYPE INSULATION AS ORIGINAL (AT LEAST 105°C) USE COPPER CONDUCTOR ONLY.
 - TO CHANGE EVAPORATOR MOTOR SPEED MOVE WHITE AND YELLOW LEADS FROM EM "2" AND "3" TO "4" AND "5". IF BOTH LEADS ARE ENERGIZED, THE HIGHER SPEED SETTING IS USED.
 - FOR 208 VOLT TRANSFORMER OPERATION MOVE PURPLE WIRES FROM TERMINAL 3 TO TERMINAL 2 ON TRANSFORMER.
 - START ASSIST FACTORY EQUIPPED WHEN REQUIRED
 - USE COPPER CONDUCTORS ONLY.
- ++ USE N.E.C. CLASS 2 WIRE

SEE UNIT RATING PLATE FOR TYPE AND SIZE OF OVER CURRENT PROTECTION

Wiring is subject to change. Always refer to the wiring diagram on the unit for the most up-to-date wiring.

HIGH VOLTAGE!
DISCONNECT ALL POWER BEFORE SERVICING OR INSTALLING THIS UNIT. MULTIPLE POWER SOURCES MAY BE PRESENT. FAILURE TO DO SO MAY CAUSE PROPERTY DAMAGE, PERSONAL INJURY OR DEATH.
WARNING

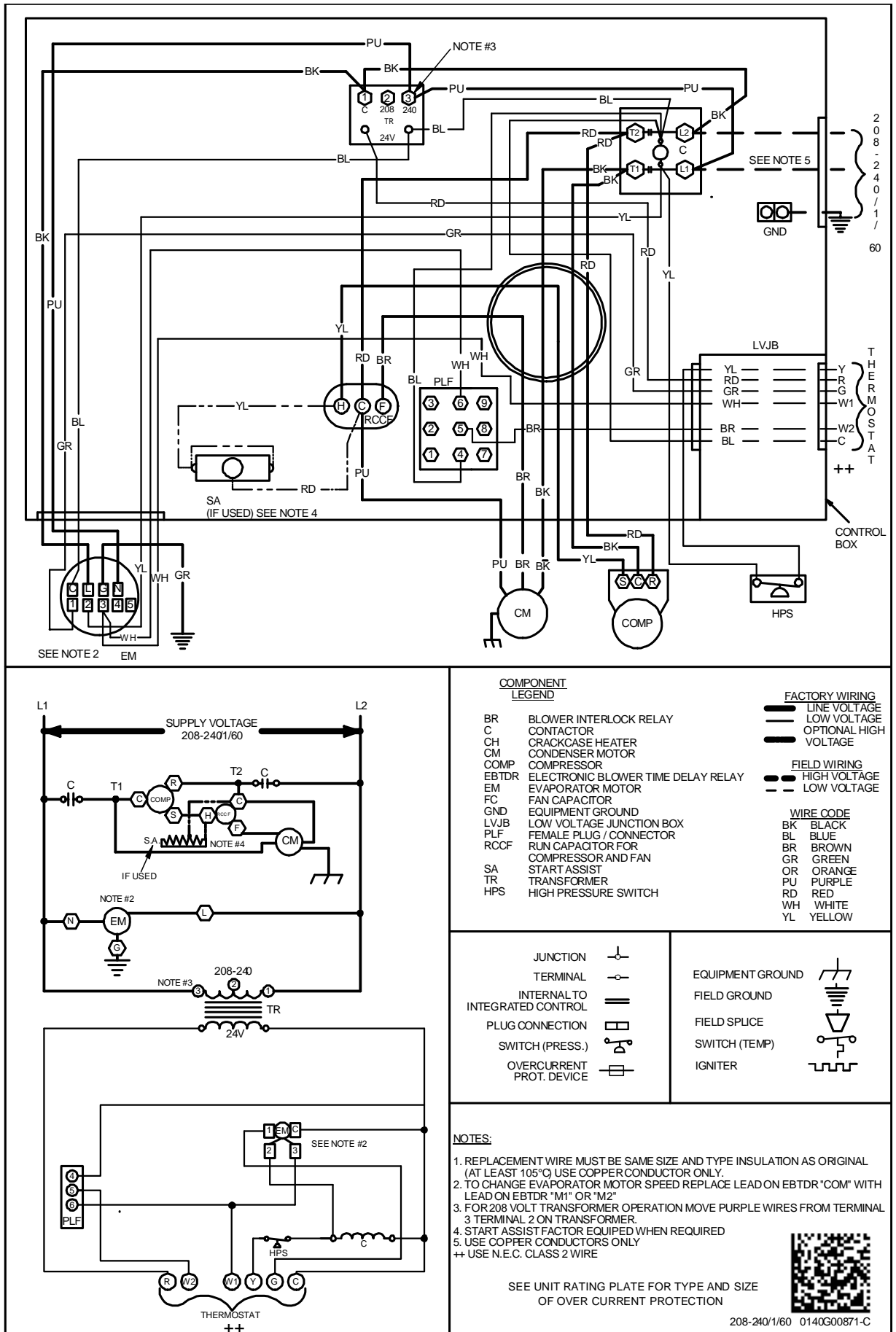

Wiring is subject to change. Always refer to the wiring diagram on the unit for the most up-to-date wiring.



HIGH VOLTAGE!
 DISCONNECT ALL POWER BEFORE SERVICING OR INSTALLING THIS UNIT. MULTIPLE POWER SOURCES MAY BE PRESENT. FAILURE TO DO SO MAY CAUSE PROPERTY DAMAGE, PERSONAL INJURY OR DEATH.

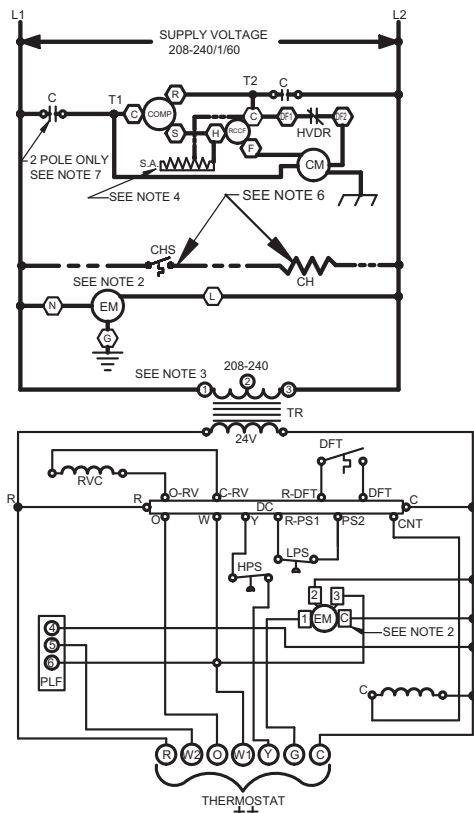
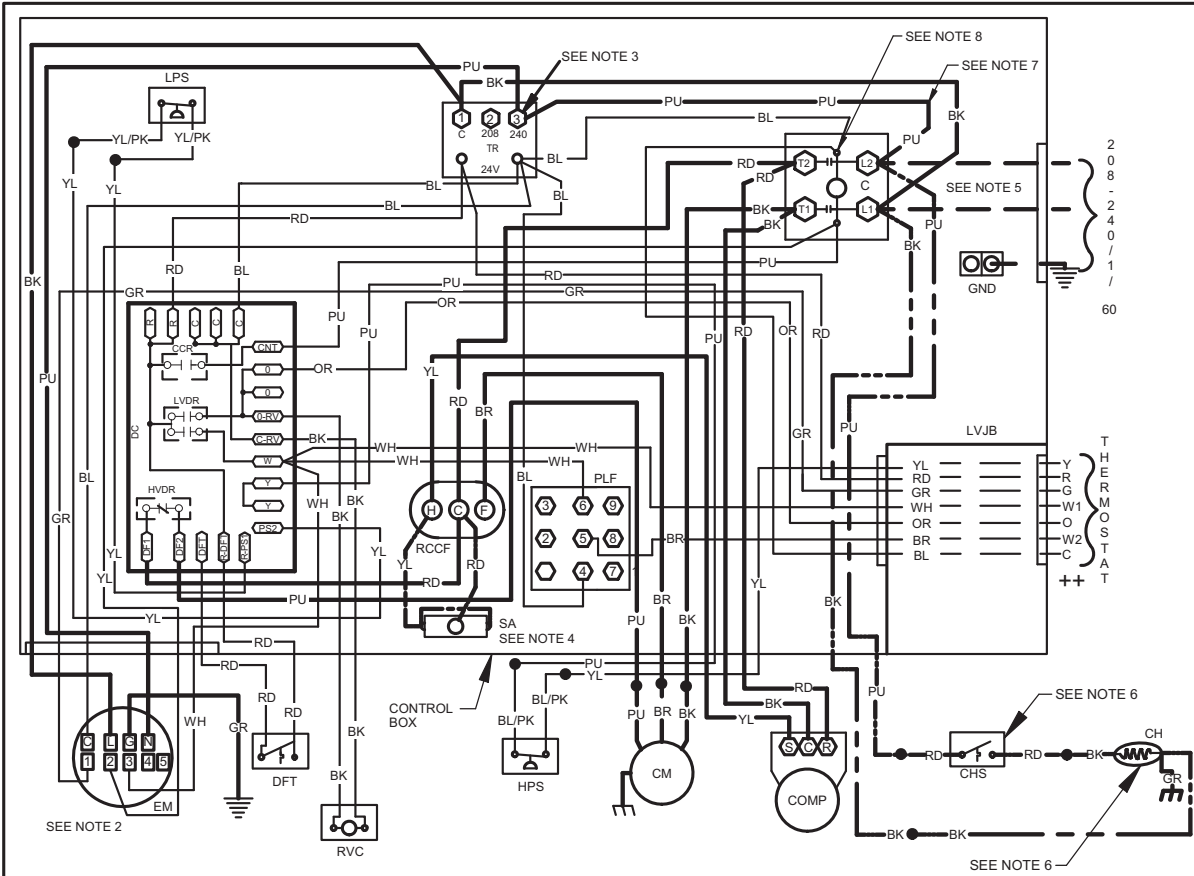

COMPONENT LEGEND

- C CONTACTOR
- CCR COMPRESSOR CONTACTOR RELAY
- CH CRANKCASE HEATER
- CHS CRANKCASE HEATER SWITCH
- CM CONDENSER MOTOR
- COMP COMPRESSOR
- DC DEFROST CONTROL
- DFT DEFROST THERMOSTAT
- EM EVAPORATOR MOTOR
- EQUIPMENT GROUND
- HVDR HIGH VOLTAGE DEFROST RELAY
- LPS LOW PRESSURE SWITCH
- LVDR LOW VOLTAGE DEFROST RELAY
- LVJB LOW VOLTAGE JUNCTION BOX
- PLF FEMALE PLUG / CONNECTOR
- RVC REVERSING VALVE COIL
- RCCF RUN CAPACITOR FOR COMPRESSOR AND FAN
- SA START ASSIST
- TR TRANSFORMER
- HPS HIGH PRESSURE SWITCH

FACTORY WIRING

- LINE VOLTAGE
- LOW VOLTAGE
- OPTIMAL HIGH VOLTAGE

FIELD WIRING

- HIGH VOLTAGE
- - - LOW VOLTAGE

WIRE CODE

- BK BLACK
- BL BLUE
- BR BROWN
- GR GREEN
- OR ORANGE
- PU PURPLE
- RD RED
- WH WHITE
- YL YELLOW

- JUNCTION
- TERMINAL
- INTERNAL TO INTEGRATED CONTROL
- PLUG CONNECTION
- IGNITER
- SWITCH (PRESS.)
- OVERCURRENT PROT. DEVICE

- EQUIPMENT GROUND
- FIELD GROUND
- FIELD SPLICE
- SWITCH (TEMP)

NOTES:

1. REPLACEMENT WIRE MUST BE SAME SIZE AND TYPE INSULATION AS ORIGINAL (AT LEAST 105°C) USE COPPER CONDUCTOR ONLY.
2. TO CHANGE EVAPORATOR MOTOR SPEED MOVE WHITE AND YELLOW LEADS FROM EM"2" AND "3" TO "4" AND "5". IF BOTH LEADS ARE ENERGIZED, THE HIGHER SPEED SETTING IS USED.
3. FOR 208 VOLT TRANSFORMER OPERATION MOVE PURPLE WIRES FROM TERMINAL 3 TO TERMINAL 2 ON TRANSFORMER.
4. START ASSIST FACTORY EQUIPPED WHEN REQUIRED
5. USE COPPER CONDUCTORS ONLY
- ++ USE N.E.C. CLASS 2 WIRE
6. CRANKCASE HEATER AND CRANKCASE HEATER SWITCH FACTORY EQUIPPED WHEN REQUIRED.
7. DOUBLE POLE CONTACTOR SHOWN. SINGLE POLE CONTACTOR COULD BE FACTORY EQUIPPED AS AN ALTERNATE CONFIGURATION.
8. COMMON SIDE OF CONTACTOR CAN NOT BE GROUNDED OR CONNECTED TO ANY OTHER COMMON (24V).

SEE UNIT RATING PLATE FOR TYPE AND SIZE OF OVER CURRENT PROTECTION



0140G01640-C

Wiring is subject to change. Always refer to the wiring diagram on the unit for the most up-to-date wiring.