

INSTALLATION INSTRUCTIONS

PACKAGED AIR CONDITIONERS

FEATURING EARTH-FRIENDLY R-410A REFRIGERANT: 
RACAZR (2-5 TONS)



DO NOT DESTROY THIS MANUAL
PLEASE READ CAREFULLY AND KEEP IN A SAFE PLACE FOR FUTURE REFERENCE BY A SERVICEMAN

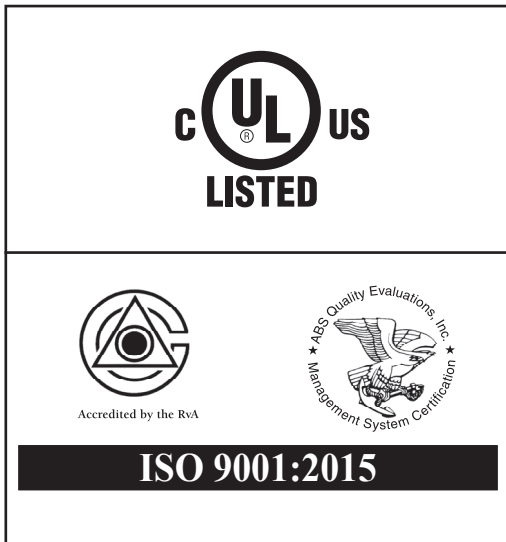

 **RECOGNIZE THIS SYMBOL AS AN INDICATION OF IMPORTANT SAFETY INFORMATION!**

▲ WARNING

THESE INSTRUCTIONS ARE INTENDED AS AN AID TO QUALIFIED, LICENSED SERVICE PERSONNEL FOR PROPER INSTALLATION, ADJUSTMENT AND OPERATION OF THIS UNIT. READ THESE INSTRUCTIONS THOROUGHLY BEFORE ATTEMPTING INSTALLATION OR OPERATION. FAILURE TO FOLLOW THESE INSTRUCTIONS MAY RESULT IN IMPROPER INSTALLATION, ADJUSTMENT, SERVICE OR MAINTENANCE POSSIBLY RESULTING IN FIRE, ELECTRICAL SHOCK, PROPERTY DAMAGE, PERSONAL INJURY OR DEATH.

TABLE OF CONTENTS

I. Safety Information.....	3	XI. Condensate Drain.....	11
II. Breakdown Page.....	4	XII. Electrical Wiring.....	12
III. Introduction.....	5	A. Power Wiring.....	12
IV. Checking Product Received.....	5	B. Special Instructions for Power Wiring with Aluminum Conductors.....	12
V. Specifications.....	5	C. Control Wiring.....	13
A. General.....	5	D. Internal Wiring.....	13
B. Major Components.....	5	E. Grounding.....	13
C. R-410A Refrigerant.....	5	F. Thermostat.....	13
1. Specifications of R-410A.....	5	XIII. Crankcase Heat.....	13
2. Quick Reference Guide for R-410A.....	5	XIV. Pre-Start Check.....	13
3. Evaporator Coil / TXV.....	5	XV. Startup.....	14
4. Tools Required for Installing & Servicing R-410A Models.....	5	XVI. Operation.....	14
VI. Unit Dimensions.....	8	XVII. Auxiliary Heat.....	14
VII. Installation.....	8	A. Control System Operation.....	14
A. General.....	8	XVIII. Blower Motor Speed Taps.....	14
1. Pre-Installation Check Points.....	8	XIX. General Data.....	15-18
2. Location Considerations.....	8	XX. Electrical Data.....	19-20
B. Outside Slab Installation.....	8	XXI. Airflow Performance.....	21-24
C. Clearances.....	8	XXII. Heater Kits Characteristics.....	25-27
D. Rooftop Installation.....	8	XXIII. Wiring Diagrams.....	28-33
VIII. Ductwork.....	11	XXIV. Troubleshooting Chart.....	34
IX. Filters.....	11		
X. Conversion Procedure.....	11		

IMPORTANT: TO INSURE PROPER INSTALLATION AND OPERATION OF THIS PRODUCT, COMPLETELY READ ALL INSTRUCTIONS PRIOR TO ATTEMPTING TO ASSEMBLE, INSTALL, OPERATE, MAINTAIN OR REPAIR THIS PRODUCT. UPON UNPACKING OF THE FURNACE, INSPECT ALL PARTS FOR DAMAGE PRIOR TO INSTALLATION AND START-UP.

I. SAFETY INFORMATION

WARNING

PROPOSITION 65: THIS APPLIANCE CONTAINS FIBERGLASS INSULATION. RESPIRABLE PARTICLES OF FIBERGLASS ARE KNOWN TO THE STATE OF CALIFORNIA TO CAUSE CANCER.

WARNING

THE MANUFACTURER'S WARRANTY DOES NOT COVER ANY DAMAGE OR DEFECT TO THE AIR CONDITIONER CAUSED BY THE ATTACHMENT OR USE OF ANY COMPONENTS, ACCESSORIES OR DEVICES (OTHER THAN THOSE AUTHORIZED BY THE MANUFACTURER) INTO, ONTO OR IN CONJUNCTION WITH THE AIR CONDITIONER. YOU SHOULD BE AWARE THAT THE USE OF UNAUTHORIZED COMPONENTS, ACCESSORIES OR DEVICES MAY ADVERSELY AFFECT THE OPERATION OF THE AIR CONDITIONER AND MAY ALSO ENDANGER LIFE AND PROPERTY. THE MANUFACTURER DISCLAIMS ANY RESPONSIBILITY FOR SUCH LOSS OR INJURY RESULTING FROM THE USE OF SUCH UNAUTHORIZED COMPONENTS, ACCESSORIES OR DEVICES.

WARNING

THE UNIT MUST BE PERMANENTLY GROUNDED. A GROUNDING LUG IS PROVIDED IN THE ELECTRIC HEAT KIT FOR A GROUND WIRE. (SEE FIGURES 11 AND 12.) FAILURE TO GROUND THIS UNIT CAN RESULT IN FIRE OR ELECTRICAL SHOCK CAUSING PROPERTY DAMAGE, SEVERE PERSONAL INJURY OR DEATH.

WARNING

DISCONNECT ALL POWER TO THE UNIT BEFORE STARTING MAINTENANCE. FAILURE TO DO SO CAN RESULT IN SEVERE ELECTRICAL SHOCK OR DEATH.

WARNING

ONLY ELECTRIC HEATER KITS SUPPLIED BY THIS MANUFACTURER AS DESCRIBED IN THIS PUBLICATION HAVE BEEN DESIGNED, TESTED, AND EVALUATED BY A NATIONALLY RECOGNIZED SAFETY TESTING AGENCY FOR USE WITH THIS UNIT. USE OF ANY OTHER MANUFACTURED ELECTRIC HEATERS INSTALLED WITHIN THIS UNIT MAY CAUSE HAZARDOUS CONDITIONS RESULTING IN PROPERTY DAMAGE, FIRE, BODILY INJURY OR DEATH.

WARNING

DISCONNECT MAIN ELECTRICAL POWER TO THE UNIT BEFORE ATTEMPTING TO CHANGE BLOWER SPEEDS. FAILURE TO DO SO MAY RESULT IN ELECTRICAL SHOCK OR SEVERE PERSONAL INJURY OR DEATH.

CAUTION

R-410A SYSTEMS OPERATE AT HIGHER PRESSURES THAN R-22 SYSTEMS. DO NOT USE R-22 SERVICE EQUIPMENT OR COMPONENTS ON R-410A EQUIPMENT.

WARNING

IMPORTANT: ALL MANUFACTURER PRODUCTS MEET CURRENT FEDERAL OSHA GUIDELINES FOR SAFETY. CALIFORNIA PROPOSITION 65 WARNINGS ARE REQUIRED FOR CERTAIN PRODUCTS, WHICH ARE NOT COVERED BY THE OSHA STANDARDS.

CALIFORNIA'S PROPOSITION 65 REQUIRES WARNINGS FOR PRODUCTS SOLD IN CALIFORNIA THAT CONTAIN, OR PRODUCE, ANY OF OVER 600 LISTED CHEMICALS KNOWN TO THE STATE OF CALIFORNIA TO CAUSE CANCER OR BIRTH DEFECTS SUCH AS FIBERGLASS INSULATION, LEAD IN BRASS, AND COMBUSTION PRODUCTS FROM NATURAL GAS.

ALL "NEW EQUIPMENT" SHIPPED FOR SALE IN CALIFORNIA WILL HAVE LABELS STATING THAT THE PRODUCT CONTAINS AND/OR PRODUCES PROPOSITION 65 CHEMICALS. ALTHOUGH WE HAVE NOT CHANGED OUR PROCESSES, HAVING THE SAME LABEL ON ALL OUR PRODUCTS FACILITATES MANUFACTURING AND SHIPPING. WE CANNOT ALWAYS KNOW "WHEN, OR IF" PRODUCTS WILL BE SOLD IN THE CALIFORNIA MARKET.

YOU MAY RECEIVE INQUIRIES FROM CUSTOMERS ABOUT CHEMICALS FOUND IN, OR PRODUCED BY, SOME OF OUR HEATING AND AIR-CONDITIONING EQUIPMENT, OR FOUND IN NATURAL GAS USED WITH SOME OF OUR PRODUCTS. LISTED BELOW ARE THOSE CHEMICALS AND SUBSTANCES COMMONLY ASSOCIATED WITH SIMILAR EQUIPMENT IN OUR INDUSTRY AND OTHER MANUFACTURERS.

- GLASS WOOL (FIBERGLASS) INSULATION
- CARBON MONOXIDE (CO)
- FORMALDEHYDE
- BENZENE

MORE DETAILS ARE AVAILABLE AT THE WEBSITES FOR OSHA (OCCUPATIONAL SAFETY AND HEALTH ADMINISTRATION), AT WWW.OSHA.GOV AND THE STATE OF CALIFORNIA'S OEHHA (OFFICE OF ENVIRONMENTAL HEALTH HAZARD ASSESSMENT), AT WWW.OEHHA.ORG. CONSUMER EDUCATION IS IMPORTANT SINCE THE CHEMICALS AND SUBSTANCES ON THE LIST ARE FOUND IN OUR DAILY LIVES. MOST CONSUMERS ARE AWARE THAT PRODUCTS PRESENT SAFETY AND HEALTH RISKS, WHEN IMPROPERLY USED, HANDLED AND MAINTAINED.

WARNING

THE MANUFACTURER'S WARRANTY DOES NOT COVER ANY DAMAGE OR DEFECT TO THE AIR CONDITIONER CAUSED BY THE ATTACHMENT OR USE OF ANY COMPONENTS, ACCESSORIES OR DEVICES (OTHER THAN THOSE AUTHORIZED BY THE MANUFACTURER) INTO, ONTO OR IN CONJUNCTION WITH THE AIR CONDITIONER. YOU SHOULD BE AWARE THAT THE USE OF UNAUTHORIZED COMPONENTS, ACCESSORIES OR DEVICES MAY ADVERSELY AFFECT THE OPERATION OF THE AIR CONDITIONER AND MAY ALSO ENDANGER LIFE AND PROPERTY. THE MANUFACTURER DISCLAIMS ANY RESPONSIBILITY FOR SUCH LOSS OR INJURY RESULTING FROM THE USE OF SUCH UNAUTHORIZED COMPONENTS, ACCESSORIES OR DEVICES.

II. BREAKDOWN PAGE

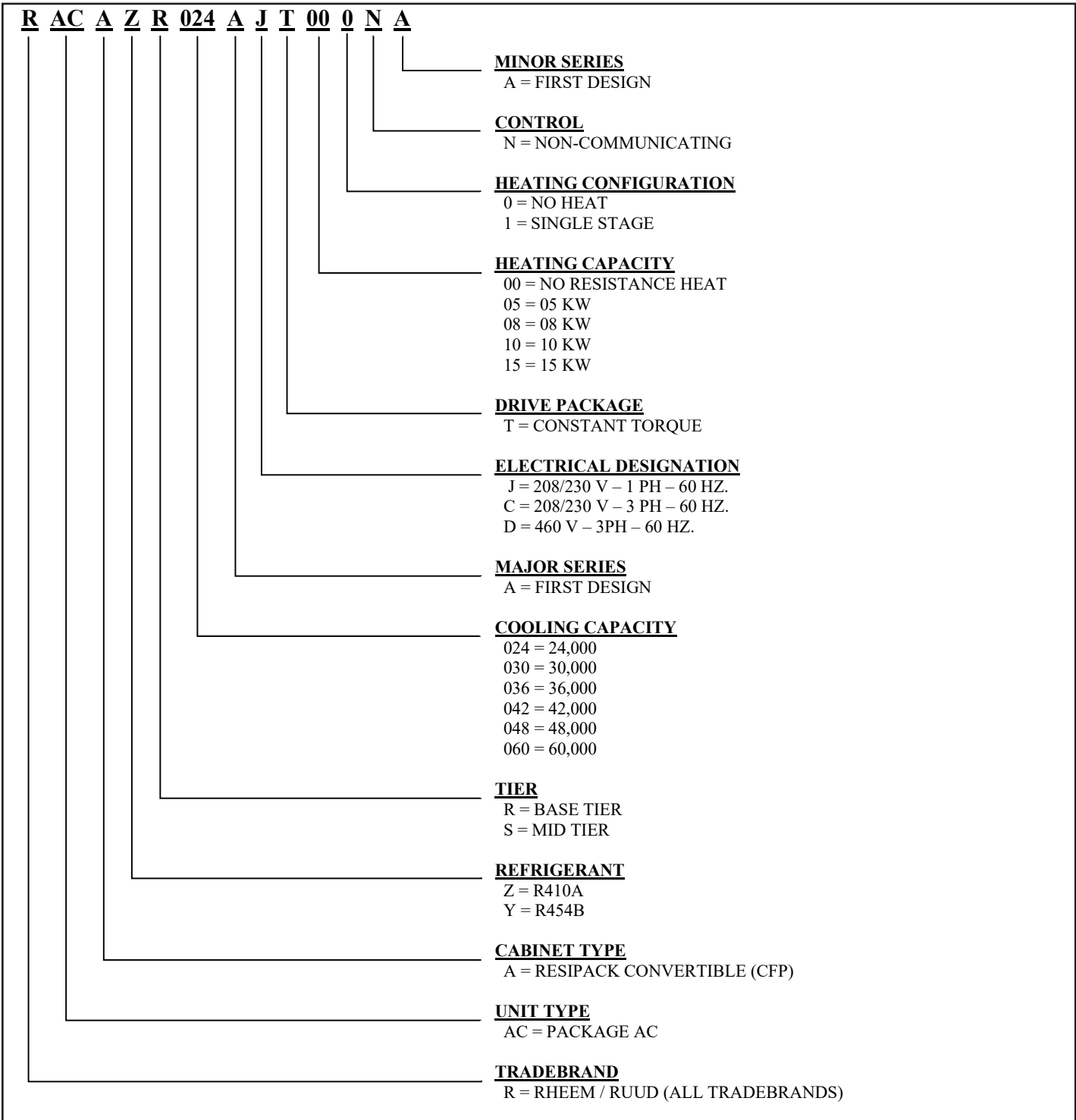

III. INTRODUCTION

This booklet contains the installation and operating instructions for your self-contained air conditioner. There are a few precautions that should be taken to derive maximum satisfaction from it. Improper installation can result in unsatisfactory operation or dangerous conditions.

Read this booklet and any instructions packaged with separate equipment required to make up the system prior to installation. Give this booklet to the owner and explain its provisions. The owner should retain this booklet for future reference.

IV. CHECKING PRODUCT RECEIVED

Upon receiving the unit, inspect it for any damage from shipment. Claims for damage, either shipping or concealed, should be filed immediately with the shipping company. Check the unit model number, electrical characteristics, and accessories to determine if they are correct.

V. SPECIFICATIONS

A. GENERAL

The Packaged Air Conditioner is available without heat or with 5, 10, or 15 kW electric heat. Cooling capacities of 2, 2½, 3, 3½, 4 and 5 nominal tons of cooling are available. Units are convertible from end supply and return to bottom supply and return by relocation of supply and return air access panels. See cover installation detail.

The units are weatherized for mounting outside of the building.

The information on the rating plate is in compliance with the FTC and DOE rating for single phase units. The following information is for three phase units which **are not** covered under the DOE certification program.

1. The energy consumption of the ignition system used with this unit is 9 watts.
2. The efficiency rating of this unit is a product thermal efficiency rating determined under continuous operating conditions independent of any installed system.

B. MAJOR COMPONENTS

The unit includes a hermetically sealed refrigerating system (consisting of a compressor, condenser coil, evaporator coil with capillary tube assembly), a circulation air blower, a condenser fan, and all necessary internal electrical wiring. The cooling system of these units is factory-evacuated, charged and performance tested. Refrigerant amount and type are indicated on rating plate.

C. R-410A REFRIGERANT

All units are factory charged with R-410A refrigerant.

1. Specification of R-410A:

Application: R-410A is not a drop-in replacement for R-22; equipment designs must accommodate its higher pressures. It cannot be retrofitted into R-22 units.

Pressure: The pressure of R-410A is approximately

60% (1.6 times) greater than R-22. Recovery and recycle equipment, pumps, hoses and the like need to have design pressure ratings appropriate for R-410A. *Manifold sets need to range up to 800 psig high-side and 250 psig low-side with a 550 psig low-side retard. Hoses need to have a service pressure rating of 800 psig. Recovery cylinders need to have a 400 psig service pressure rating. DOT 4BA400 or DOT BW400.*

Combustibility: At pressures above 1 atmosphere, mixture of R-410A and air can become combustible. **R-410A and air should never be mixed in tanks or supply lines, or be allowed to accumulate in storage tanks. Leak checking should never be done with a mixture of R-410A and air.** Leak checking can be performed safely with nitrogen or a mixture of R-410A and nitrogen.

2. Quick Reference Guide For R-410A

- R-410A refrigerant operates at approximately 60% higher pressure (1.6 times) than R-22. Ensure that servicing equipment is designed to operate with R-410A.
- R-410A refrigerant cylinders are pink.
- R-410A, as with other HFC's is only compatible with POE oils.
- Vacuum pumps will not remove moisture from POE oil.
- R-410A systems are to be charged with liquid refrigerants. Prior to March 1999, R-410A refrigerant cylinders had a dip tube. These cylinders should be kept upright for equipment charging. Post March 1999 cylinders do not have a dip tube and should be inverted to ensure liquid charging of the equipment.
- Do not install a suction line filter drier in the liquid line.
- A liquid line filter drier is standard on every unit.
- Desiccant (drying agent) must be compatible for POE oils and R-410A.

3. Evaporator Coil / TXV

The thermostatic expansion valve is specifically designed to operate with R-410A. **DO NOT use an R-22 TXV. The existing evaporator must be replaced with the factory specified TXV evaporator specifically designed for R-410A.**

4. Tools Required For Installing & Servicing R-410A Models

Manifold Sets:

- Up to 800 PSIG High side
- Up to 250 PSIG Low Side
- 550 PSIG Low Side Retard

Manifold Hoses:

- Service Pressure Rating of 800 PSIG

Recovery Cylinders:

- 400 PSIG Pressure Rating
- Dept. of Transportation 4BA400 or BW400

▲ CAUTION

R-410A systems operate at higher pressures than R-22 systems. Do not use R-22 service equipment or components on R-410A equipment.

VI. UNIT DIMENSIONS

FIGURE 1

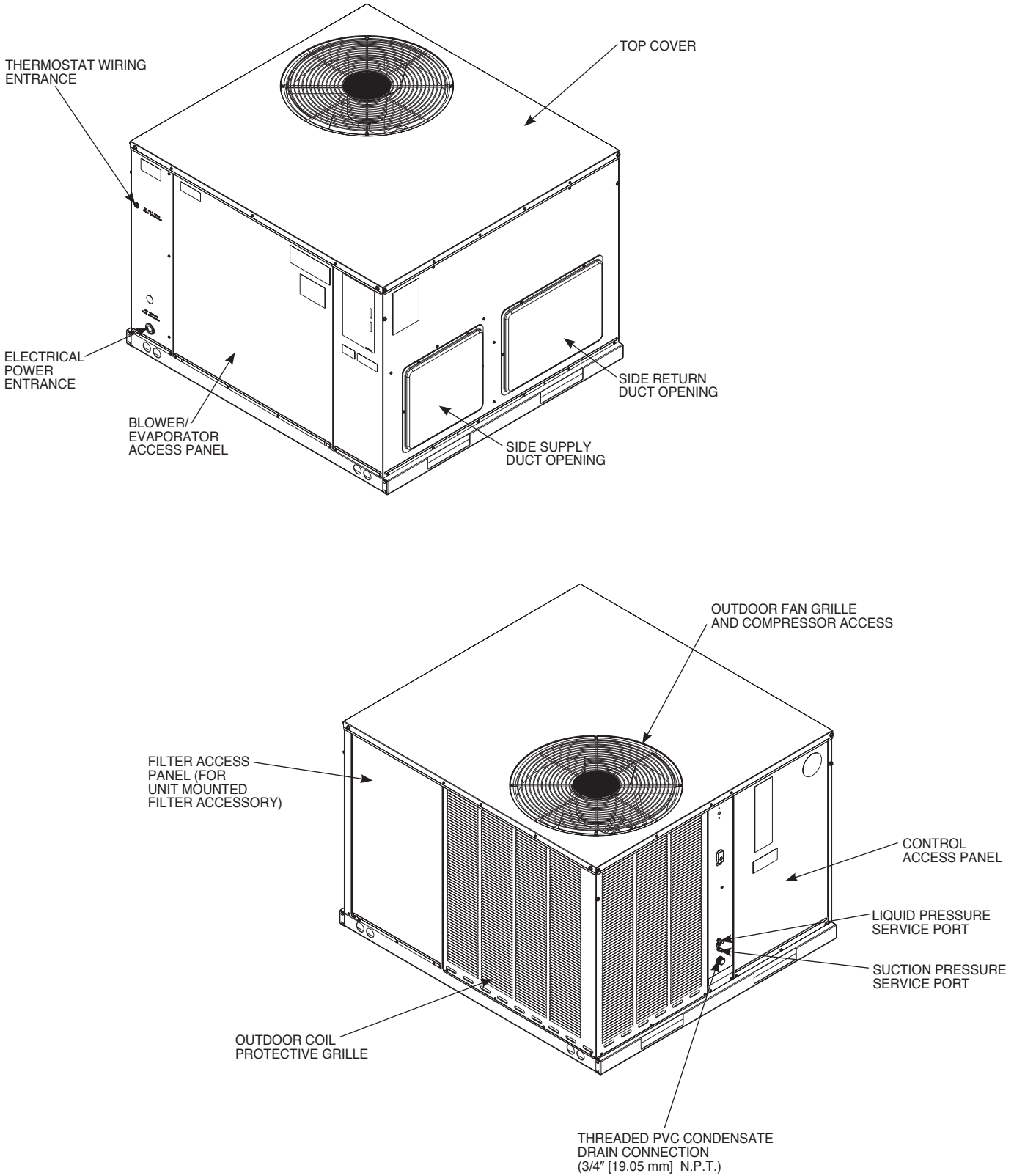
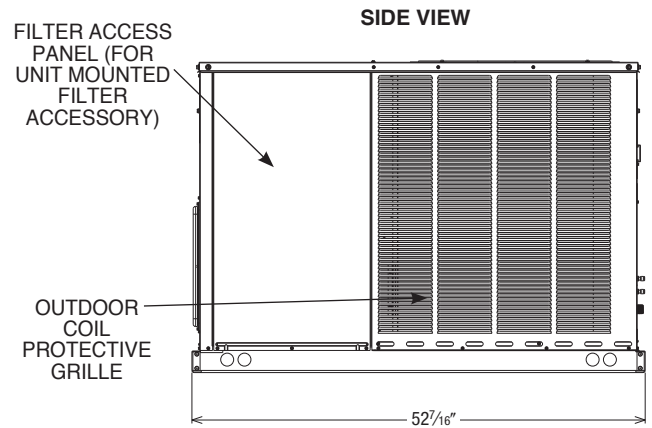
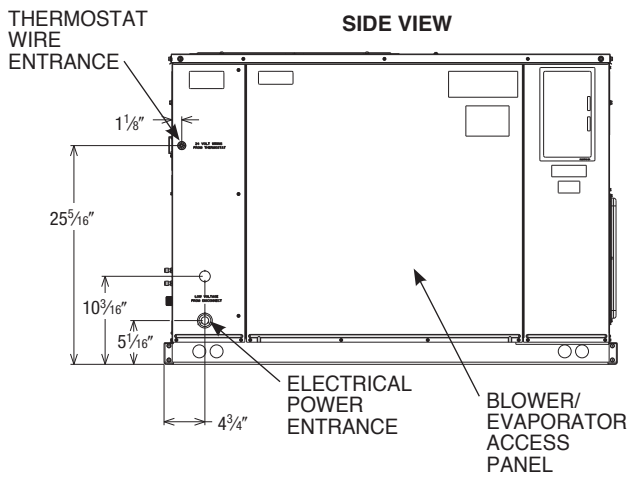
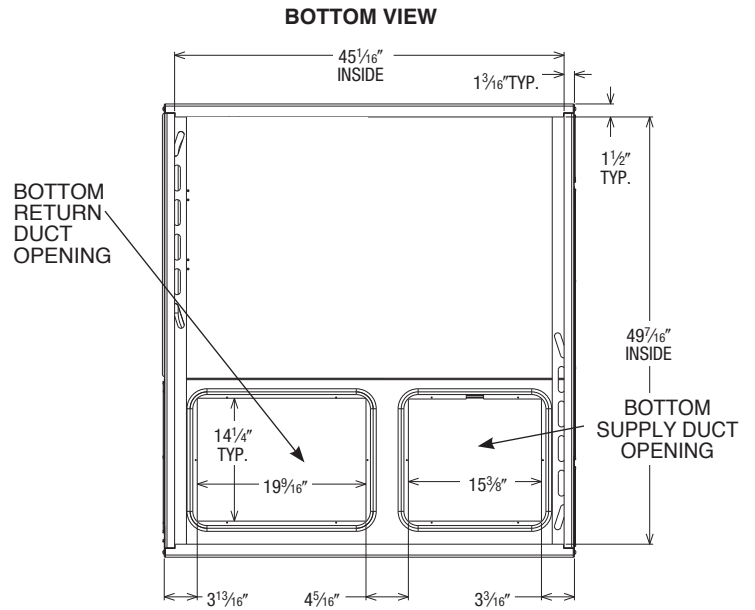
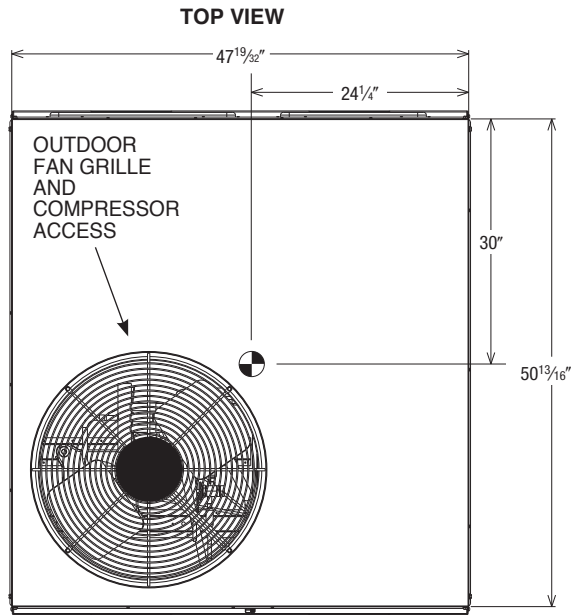
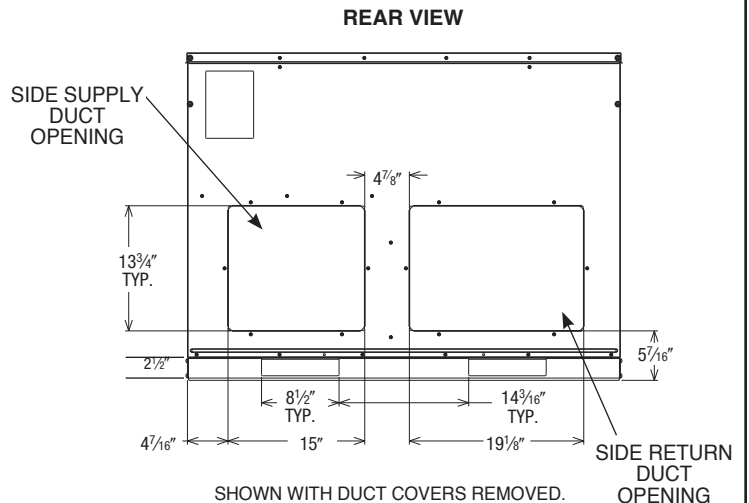
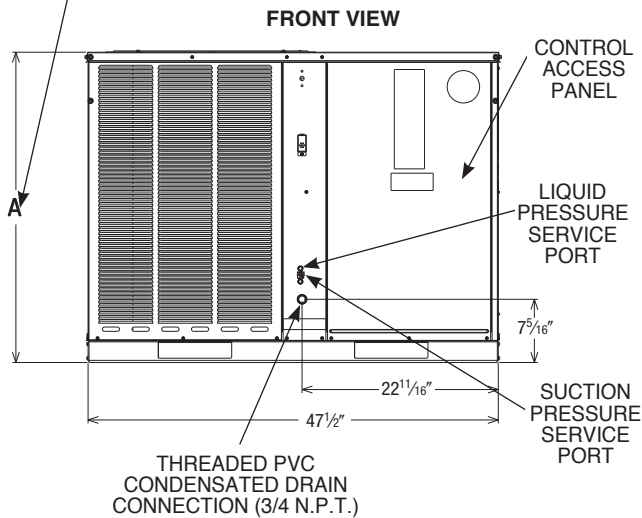

FIGURE 1 (continued)



Models RACAZR	Height "A"
024, 030, 036	35 ^{15/16} "
042, 048, 060	41"



IMPORTANT: Unit must be level to prevent water migration.

VII. INSTALLATION

A. GENERAL

1. PRE-INSTALLATION CHECK-POINTS

Before attempting any installation, the following points should be carefully considered:

- a. Structural strength of supporting members. (rooftop installation)
- b. Clearances and provision for servicing.
- c. Power supply and wiring.
- d. Air duct connections.
- e. Drain facilities and connections.
- f. Location for minimum noise.

2. LOCATION CONSIDERATIONS (CORROSIVE ENVIRONMENT)

These units are designed for outdoor installations. They can be mounted on a slab or rooftop. They are not to be installed within any part of a structure such as an attic, crawl space, closet, or any other place where condenser air flow is restricted or other than outdoor ambient conditions prevail. Since the application of the units is of the outdoor type, it is important to consult your local code authorities at the time the first installation is made.

The metal parts of this unit may be subject to rust or deterioration if exposed to a corrosive environment. This oxidation could shorten the equipment's useful life. Corrosive elements include, but are not limited to, salt spray, fog or mist in seacoast areas, sulphur or chlorine from lawn watering systems, and various chemical contaminants from industries such as paper mills and petroleum refineries.

If the unit is to be installed in an area where contaminants are likely to be a problem, special attention should be given to the equipment location and exposure. Regular maintenance will reduce the buildup of contaminants and help to protect the unit's finish.

- a. Avoid having lawn sprinkler heads spray directly on the unit cabinet.
- b. In coastal areas, locate the unit on the side of the building away from the waterfront.
- c. Shielding provided by a fence or shrubs may give some protection.
- d. Elevating the unit off its slab or base enough to allow air circulation will help avoid holding water against the basepan.
- e. Frequent washing of the cabinet, fan blade and coil with fresh water will remove most of the salt or other contaminants that build up on the unit.
- f. Regular cleaning and waxing of the cabinet with an automobile polish will provide some protection.
- g. A liquid cleaner may be used several times a year to remove matter that will not wash off with water.

WARNING

DISCONNECT ALL POWER TO THE UNIT BEFORE STARTING MAINTENANCE. FAILURE TO DO SO CAN RESULT IN SEVERE ELECTRICAL SHOCK OR DEATH.

Several different types of protective coatings are offered in some areas. These coatings may provide some benefit, but the effectiveness of such coating materials cannot be verified by the equipment manufacturer.

The best protection is frequent cleaning, maintenance and minimal exposure to contaminants.

B. OUTSIDE SLAB INSTALLATION

(Typical outdoor slab installations are shown in Figures 2 and 3.)

1. Select a location where external water drainage cannot collect around the unit.
2. Provide a level concrete slab extending 3" beyond all four sides of the unit. The slab should be sufficient above grade to prevent ground water from entering the unit. **IMPORTANT:** To prevent transmission of noise or vibration, slab should not be connected to building structure.
3. The location of the unit should be such as to provide proper access for inspection and servicing.
4. Locate unit where operating sounds will not disturb owner or neighbors.
5. Locate unit so roof runoff water does not pour directly on the unit. Provide gutter or other shielding at roof level. Do not locate unit in an area where excessive snow drifting may occur or accumulate.

C. CLEARANCES

The following minimum clearances must be observed for proper unit performance and serviceability.

1. Provide 36" minimum clearance at the front and right side of the unit for service access. Provide 12" minimum clearance on the left side of the unit for air inlet.
2. Provide 60" minimum clearance between top of unit and maximum 3 foot overhang.
3. Unit is design certified for application on combustible flooring with 0" minimum clearance.
4. See Figure 2 for illustration of minimum installation-service clearances.

D. ROOFTOP INSTALLATION

(Typical rooftop installations are shown in Figures 4 and 5.)

1. Before locating the unit on the roof, make sure that the strength of the roof and beams is adequate at that point to support the weight involved. (See Electrical and Physical Data Table in this manual for weight of unit.) This is very important and user's responsibility.
2. For rigging and roof curb details, see Figures 6, 7 and 8. Use accessory lift brackets and field-furnished spreaders.
3. For roofcurb assembly, see Roofcurb Installation Instructions.
4. If the roofcurb is not used, provisions for disposing of condensate water runoff must be provided.
5. The unit should be placed on a solid and level roofcurb or platform of adequate strength.
6. The location of the unit on the roof should be such as to provide proper access for inspection and servicing.

IMPORTANT: If unit will not be put into service immediately, cover supply and return openings to prevent excessive condensation.

FIGURE 2
PACKAGED AIR CONDITIONER

OUTSIDE SLAB INSTALLATION, BASEMENT OR CRAWL SPACE DISTRIBUTION SYSTEM.

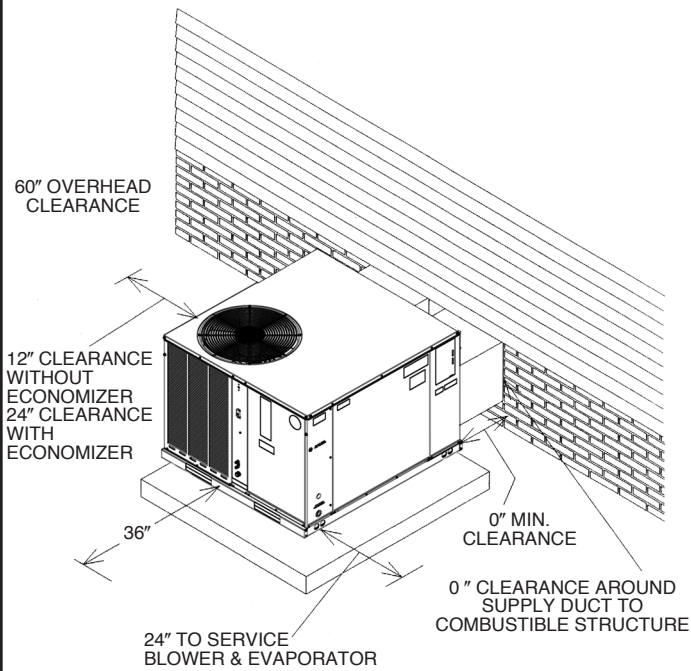

1504

FIGURE 3
PACKAGED AIR CONDITIONER

OUTSIDE SLAB INSTALLATION, CLOSET DISTRIBUTION SYSTEM, SLAB FLOOR CONSTRUCTION.

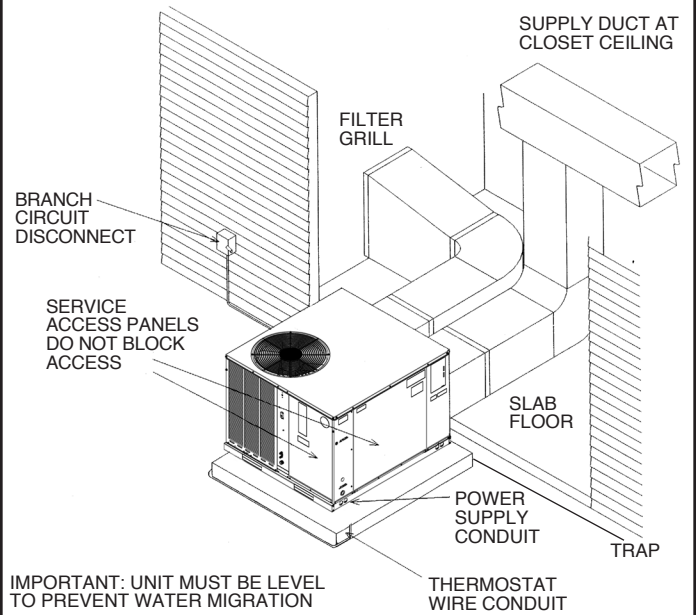

1505

FIGURE 4
PACKAGED AIR CONDITIONER

FLAT ROOFTOP INSTALLATION, ATTIC OR DROP CEILING DISTRIBUTION SYSTEM. MOUNTED ON ROOFCURB, CURB MUST BE LEVEL.

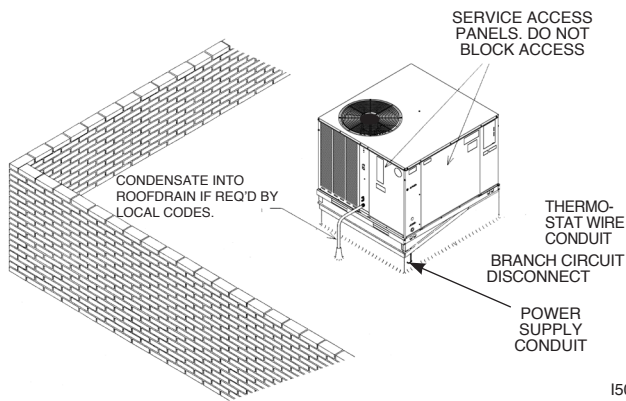

1506

FIGURE 5
PACKAGED AIR CONDITIONER

PITCHED ROOFTOP INSTALLATION, ATTIC OR DROP CEILING DISTRIBUTION SYSTEM. MOUNTED ON ROOFCURB, CURB MUST BE LEVEL.

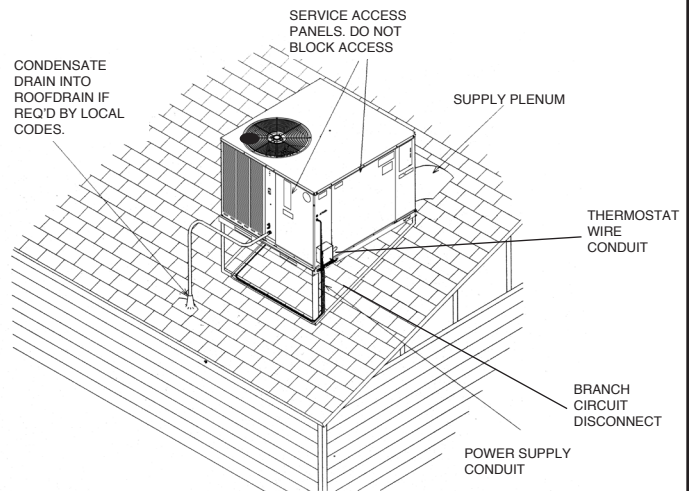

1273

FIGURE 6
PACKAGED AIR CONDITIONER
LIFTING DETAIL

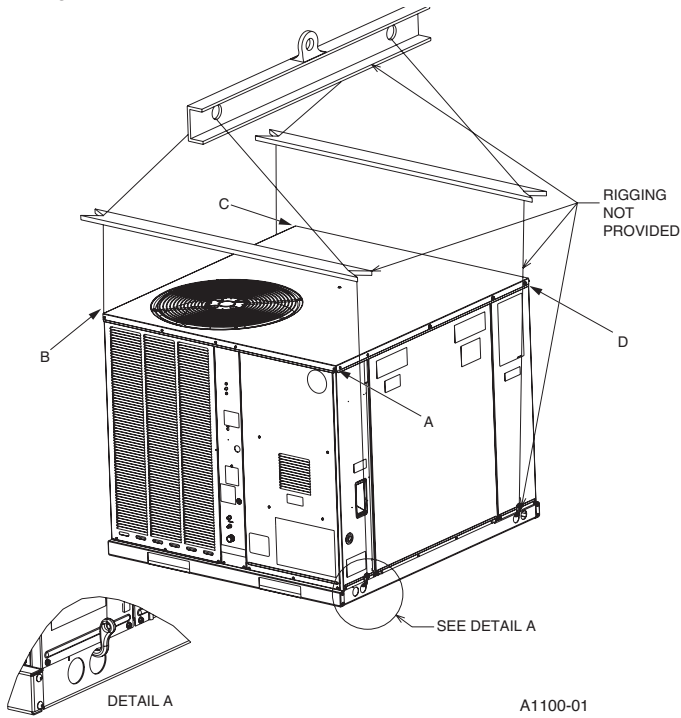

CAPACITY TONS [KW]	CORNER WEIGHTS BY PERCENTAGE (±2%)			
	A	B	C	D
2.0-5.0 [7-15.8]	20%	29%	30%	21%

FIGURE 7
ROOFCURB

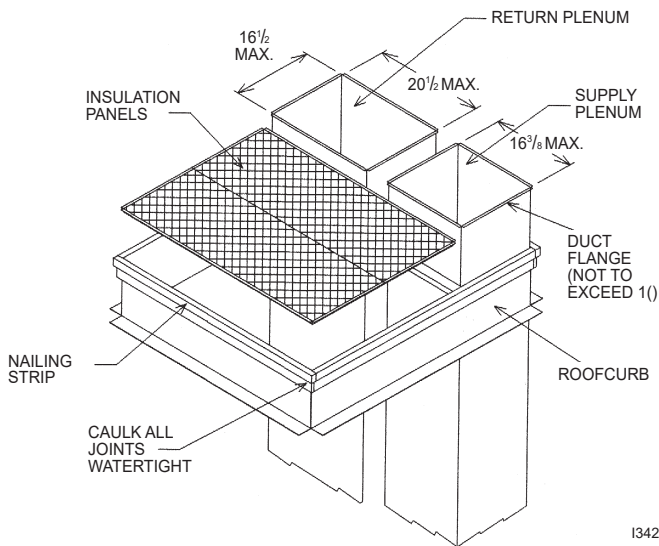
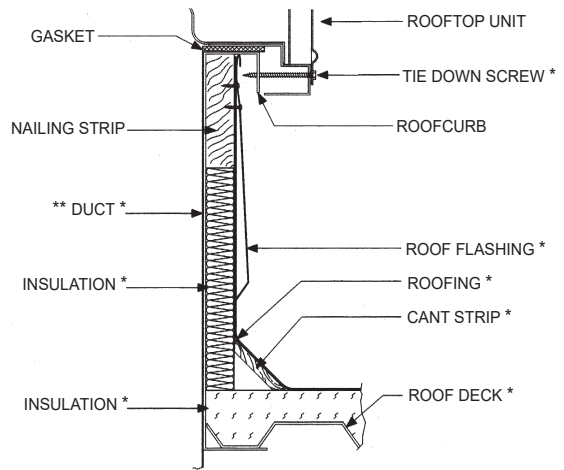

FIGURE 8
ROOFCURB



*BY CONTRACTOR
 **FOR INSTALLATION OF DUCT AS SHOWN, USE RECOMMENDED DUCT SIZES FROM ROOFCURB INSTALLATION INSTRUCTIONS. FOR DUCT FLANGE ATTACHMENT TO UNIT, SEE UNIT INSTALLATION INSTRUCTIONS (FIGURE 1) FOR SIZE OF DUCT OPENINGS.

1255

VIII. DUCTWORK

Ductwork should be fabricated by the installing contractor in accordance with local codes and NFPA90A. Industry manuals may be used as a guide when sizing and designing the duct system - contact Air Conditioning Contractors of America, 1513 16th St. N.W., Washington, D.C. 20036.

Place the unit as close to the space to be conditioned as possible, allowing clearance dimensions as indicated. Run ducts should be run as directly as possible to supply and return outlets. Use of non-flammable waterproof flexible connectors on both supply and return connections at the unit to reduce noise transmission is recommended.

It is preferable to install the unit on the roof of the structure if the registers or diffusers are located on the wall or in the ceiling. A slab installation could be considered when the registers are low on a wall or in the floor.

On ductwork exposed to outside air conditions of temperature and humidity, use a minimum of 2" of insulation and a vapor barrier. Distribution system in attic, furred space or crawl space should be insulated with at least 2" of insulation with vapor barrier. One-half to 1" thickness of insulation is usually sufficient for ductwork inside the air conditioned space.

Provide balancing dampers for each branch duct in the supply system. Properly support ductwork from the structure.

WARNING

DO NOT, UNDER ANY CIRCUMSTANCES, CONNECT RETURN DUCTWORK TO ANY OTHER HEAT PRODUCING DEVICE SUCH AS A FIREPLACE INSERT, STOVE, ETC. UNAUTHORIZED USE OF SUCH DEVICES MAY RESULT IN FIRE, CARBON MONOXIDE POISONING, EXPLOSION, PROPERTY DAMAGE, SEVERE PERSONAL INJURY OR DEATH.

IX. FILTERS

Filters are not provided with this unit. They may be supplied and installed in the return air duct by the installer. A field installed filter grille is recommended for easy and convenient access to the filters for periodic inspection and cleaning. Filters must have adequate face area for the rated air quantity of the unit. See Airflow Performance Table - or Electrical and Physical Data Table - for recommended filter size.

However, if an internal filter is required, an optional internal filter kit is available for downflow applications only. For installation, see Filter Kit Installation Instruction.

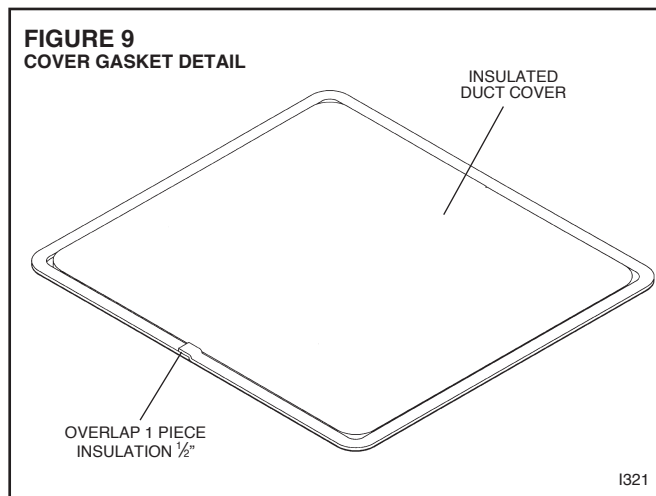

X. CONVERSION PROCEDURE

1. HORIZONTAL TO DOWNFLOW

- Remove screws and covers from the downflow supply and return sections. Both covers are accessible from the inside of the unit.
- Install gasket (supplied with parts bag) around perimeter of cover on the insulated side. In other words, the gasket is applied to the **opposite** side of flange than shown in Figure 9.
- Install covers on the outside of the unit over the horizontal supply and return opening using existing screws.

XI. CONDENSATE DRAIN

IMPORTANT: DO NOT OPERATE THE UNIT WITHOUT A CONDENSATE DRAIN TRAP INSTALLED.

- The condensate drain tube has a threaded male 3/4" NPT connection.
- Use a thin layer of Teflon tape or paste on drain pan connections and install only hand tight. It is recommended that PVC cement not be used so that the drain line can be easily cleaned in the future.
- Drain line must be no smaller than the drain tube outlet and adequately sized to accommodate the condensate discharge from the unit.
- Drain line must be routed to an acceptable drain or outdoors in accordance with local codes.
- Do not connect the condensate drain line to a closed sewer pipe. Connection to a vented sewer line is allowed.
- Drain line may need insulation or freeze protection in certain applications.
- The drain line includes a 3/16" hole on top of the line near the bulkhead to relieve negative pressure and allow proper drainage in the event of a dried out trap.
- If condensate is running out of this hole during cooling operation, check for obstruction in the drain line.

NOTICE

DO NOT OPERATE UNIT WITHOUT CONDENSATE DRAIN TRAP

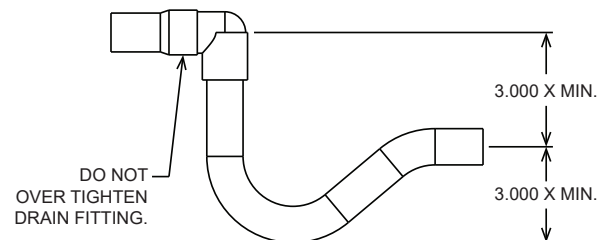

92-22205-133-00

XII. ELECTRICAL WIRING

Field wiring must comply with the National Electrical Code* and local ordinances that may apply.

*C.E.C. in Canada

A. POWER WIRING

WARNING

TURN OFF THE MAIN ELECTRICAL POWER AT THE BRANCH CIRCUIT DISCONNECT CLOSEST TO THE UNIT BEFORE ATTEMPTING ANY WIRING. FAILURE TO DO SO CAN CAUSE ELECTRICAL SHOCK RESULTING IN PERSONAL INJURY OR DEATH.

1. It is important that proper electrical power is available at the unit. Voltage should not vary more than 10% from that stamped on the unit rating plate. On three phase units, phases must be balanced within 3%.
2. Install a branch circuit disconnect within sight of the unit in accordance with the N.E.C., C.E.C., or local codes.
3. For branch circuit wiring (main power supply to unit disconnect), the minimum wire size can be determined from Table A using the circuit ampacity found on the unit nameplate.
4. This unit incorporates single point electrical connection for unit and electric heat accessory.
5. Power wiring must be run in grounded rain-tight conduit. Connect the power field wiring as follows:
 - a. NO ELECTRIC HEAT - Connect the field wires directly to the contactor in the unit control box. Connect ground wire to ground lug.
 - b. WITH ELECTRIC HEAT - Connect the field wires to the terminal block on the electric heater kit. Connect the ground wire to the ground lug on the heater kit.

NOTE: For field installation of the heater kit, follow the instructions provided with the heater kit.

6. The pigtail wires in the electric heat box are factory wired to the contactor in the control box and are protected by internal fuses in the hinged fuse box mounted under the control box. See label on fuse box cover for fuse sizing.
7. DO NOT connect aluminum field wires to electric heat kit power input terminals.

**TABLE A
BRANCH CIRCUIT COPPER WIRE SIZE
(BASED ON 1% VOLTAGE DROP)***

	200	6	4	4	4	3	3	2	2
SUPPLY WIRE	150	8	6	6	4	4	4	3	3
LENGTH-FEET	100	10	8	8	6	6	6	4	4
	50	14	12	10	10	8	8	6	6
		15	20	25	30	35	40	45	50

BRANCH CIRCUIT AMPACITY

*Taken from National Electric Code

B. SPECIAL INSTRUCTIONS FOR POWER WIRING WITH ALUMINUM CONDUCTORS.

1. Select the equivalent aluminum wire size from Table B:
2. Attach a length (6" or more) of recommended size copper wire to the unit terminals L1 and L3 for single phase, L1, L2, L3 for three phase.
3. Splice copper wire pigtails to aluminum wire with U.L. recognized connectors for copper-aluminum splices (Table B). Follow these instructions very carefully to make a positive and lasting connection;
 - a. Strip insulation from aluminum conductor.
 - b. Coat the stripped end of the aluminum wire with the recommended inhibitor and wire brush aluminum surface through inhibitor. Inhibitors: Brundy, Pentex "A"; Alcoa, No. 2EJC; T&B KPOR Shield.
 - c. Clean and re-coat aluminum conductor with inhibitor.
 - d. Make the splice using the above listed wire nuts or split bolt connectors.
 - e. Coat the entire connection with inhibitor and wrap with electrical insulating tape.

WARRANTY MAY NOT APPLY IF CONNECTIONS ARE NOT MADE PER INSTRUCTIONS.

**TABLE B
WIRE SIZES**

AWG Copper Wire Size	AWG Aluminum Wire Size	Connector Type and Size (or equivalent)	
#12	#10	T&B Wire Nut	PT2
#10	#8	T&B Wire Nut	PT3
#8	#6	IlSCO Split Bolt	AK-6
#6	#4	IlSCO Split Bolt	AK-4
#4	#2	IlSCO Split Bolt	AK-2
#3	#1	IlSCO Split Bolt	AK-1/0
#2	#0	IlSCO Split Bolt	AK-1/0
#1	#00	IlSCO Split Bolt	AK-2/0
#0	#000	IlSCO Split Bolt	AK-4/0

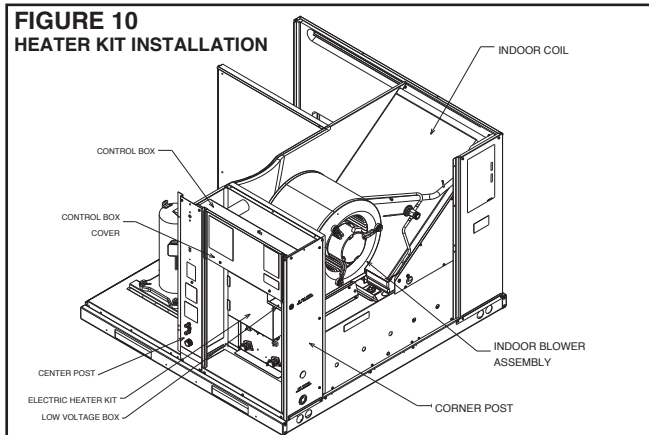

C. CONTROL WIRING (Class II)

1. Low voltage wiring should not be run in conduit with power wiring.
2. Control wiring is routed through the 7/8" hole approximately 11" from the unit top in the corner post adjacent to the control box. See Figure 10. Use a minimum #18 AWG thermostat wire. For wire lengths exceeding 50', use #16 AWG thermostat wire. The low voltage wires are connected to the unit pigtails which are supplied with the unit in the low voltage connection box located below the unit control box. See Figure 10.
3. Figures 11-14 shows wiring diagram for installation. Read your thermostat installation instructions for any special requirements for your specific thermostat. Two stage units (4 and 5 ton) require use of a thermostat capable of 2 stages of cooling.

NOTE — Units installed in Canada require that an outdoor thermostat (30,000 min. cycles of endurance) be installed and be wired with C.E.C. Class I wiring.

D. INTERNAL WIRING

A diagram of the internal wiring of this unit is located on the electrical control box cover. If any of the original wire as supplied with the appliance must be replaced, the wire gauge and insulation must be the same as original wiring.

E. GROUNDING

GROUNDING MAY ALSO BE ACCOMPLISHED BY GROUNDING THE POWER LINE CONDUIT TO THE UNIT. MAKE SURE THE CONDUIT NUT LOCKING TEETH HAVE PIERCED THE INSULATING PAINT FILM OF THE SIDE PANEL.

▲ WARNING

THE UNIT MUST BE PERMANENTLY GROUNDED. A GROUNDING LUG IS PROVIDED IN THE ELECTRIC HEAT KIT FOR A GROUND WIRE. (SEE FIGURES 10 AND 12.) FAILURE TO GROUND THIS UNIT CAN RESULT IN FIRE OR ELECTRICAL SHOCK CAUSING PROPERTY DAMAGE, SEVERE PERSONAL INJURY OR DEATH.

F. THERMOSTAT

The thermostat should be mounted on an inside wall about five feet above the floor in a location where it will not be affected by unconditioned air, sun, or drafts from open doors or other sources. READ installation instructions in thermostat package CAREFULLY because each has some different wiring requirements.

XIII. CRANKCASE HEAT(OPTIONAL)

At initial startup or after extended shutdown periods, make sure crankcase heat is energized for at least 12 hours before compressor is started (disconnect switch closed and wall thermostat "OFF" position).

Crankcase heat is not required on scroll type compressors, but may be necessary for difficult starting situations.

XIV. PRE-START CHECK

1. Is unit properly located and slightly slanted toward condensate drain?
2. Is ductwork insulated, weatherproofed, with proper spacing to combustible materials?
3. Is air free to travel to and from outdoor coil? (See Figure 2.)
4. Is the wiring correct, tight, and according to unit wiring diagram?
5. Is unit grounded?
6. Are field supplied air filters in place and clean?
7. Do the outdoor fan and indoor blower turn freely without rubbing, and are they tight on the motor shafts?
8. Has crankcase heat been on for at least 12 hours?

XV. STARTUP

1. Turn thermostat to "OFF," turn "on" power supply at disconnect switch.
2. Turn temperature setting as high as it will go.
3. Turn fan switch to "ON."
4. Indoor blower should run. Be sure it is running in the right direction.
5. Turn fan switch to "AUTO." Turn system switch to "COOL" and turn temperature setting below room temperature. Unit should run in cooling mode.
6. Is outdoor fan operating correctly in the right direction?
7. Is compressor running correctly?
8. Check the refrigerant charge using the instructions located on control box cover. Replace service port caps. Service port cores are for system access only and will leak if not tightly capped.
9. Turn thermostat system switch to proper mode "HEAT" or "COOL" and set thermostat to proper temperature setting. Record the following after the unit has run some time.
 - a. Operating Mode _____
 - b. Discharge Pressure (High) _____ PSIG
 - c. Vapor Pressure at Compressor (Low) _____ PSIG
 - d. Vapor Line Temperature at Compressor _____ °F.
 - e. Indoor Dry Bulb _____ °F.
 - f. Indoor Wet Bulb _____ °F.
 - g. Outdoor Dry Bulb _____ °F.
 - h. Outdoor Wet Bulb _____ °F.
 - i. Voltage at Contactor _____ Volts
 - j. Current at Contactor _____ Amps
 - k. Model Number _____
 - l. Serial Number _____
 - m. Location _____
 - n. Owner _____
 - o. Date _____
10. Adjust discharge air grilles and balance system.
11. Check ducts for condensation and air leaks.
12. Check unit for tubing and sheet metal rattles.
13. Instruct the owner on operation and maintenance.
14. Leave "INSTALLATION" and "USE AND CARE" instructions with owner.

XVI. OPERATION

Most single phase units are operated PSC (no start relay or start capacitor). It is important that such systems be off for a minimum of 5 minutes before restarting to allow equalization of pressures. The thermostat should not be moved to cycle unit without waiting five minutes. To do so may cause the compressor to stop on an automatic open overload device or blow a fuse. Poor electrical service can cause nuisance tripping in overloads or blow fuses.

IMPORTANT: The compressor has an internal overload protector. Under some conditions, it can take up to 2 hours for this overload to reset. Make sure overload has had time to reset before condemning the compressor.

Some models may be factory equipped with a start relay and start capacitor.

Some units are equipped with a time delay control (TDC1). The control allows the blower to operate for up to 60 seconds after the thermostat is satisfied.

XVII. AUXILIARY HEAT

A. CONTROL SYSTEM OPERATION

1. In the cooling mode, the thermostat will, on a call for cooling, energize the compressor contactor and the indoor blower relay. The indoor blower can be operated continuously by setting the thermostat fan switch at the "ON" position.
2. In the heating mode, the thermostat will energize one or more supplementary resistance heaters.

XVIII. BLOWER MOTOR SPEEDTAPS

Note: These instructions to be used in conjunction with airflow tables.

WARNING

ONLY ELECTRIC HEATER KITS SUPPLIED BY THIS MANUFACTURER AS DESCRIBED IN THIS PUBLICATION HAVE BEEN DESIGNED, TESTED, AND EVALUATED BY A NATIONALLY RECOGNIZED SAFETY TESTING AGENCY FOR USE WITH THIS UNIT. USE OF ANY OTHER MANUFACTURED ELECTRIC HEATERS INSTALLED WITHIN THIS UNIT MAY CAUSE HAZARDOUS CONDITIONS RESULTING IN PROPERTY DAMAGE, FIRE, BODILY INJURY OR DEATH.

After determining necessary CFM and speed tap, follow the steps below to change speeds.

Units with Constant Torque Motors

1. Remove blower access panel.
2. Locate wire terminals on the motor. Numbered terminals are 24V blower taps (See airflow tables for corresponding speed). The C terminal is 24V common. L, N, and G terminals are high voltage and must remain unchanged.
3. Cooling speed can be adjusted by moving appropriate wire between taps at the blower (Do not connect wires to unspecified speed taps).
4. Replace blower access panel.

XIX. GENERAL DATA - RACAZR MODELS

NOMINAL SIZES 2-5 TONS [7-17.6 kW]

Model RACAZR Series	024AJT	030AJT	036ACT	036ADT
Cooling Performance¹				Continued ->
Gross Cooling Capacity Btu [kW]	23,600 [6.91]	29,400 [8.61]	35,200 [10.31]	35,200 [10.31]
EER/SEER ²	10.6/13.4	10.6/13.4	11/14	11/14
Nominal CFM/AHRI Rated CFM [L/s]	800/810 [378/382]	1000/980 [472/462]	1200/1180 [566/557]	1200/1180 [566/557]
AHRI Net Cooling Capacity Btu [kW]	23,000 [6.74]	28,400 [8.32]	34,200 [10.02]	34,200 [10.02]
Net Sensible Capacity Btu [kW]	16,700 [4.89]	21,100 [6.18]	25,100 [7.35]	25,100 [7.35]
Net Latent Capacity Btu [kW]	6,300 [1.85]	7,300 [2.14]	9,100 [2.67]	9,100 [2.67]
Net System Power kW	2.04	2.49	2.81	2.81
Compressor				
No./Type	1/Scroll	1/Scroll	1/Scroll	1/Scroll
Outdoor Sound Rating (dB)⁵	77	79	75	75
Outdoor Coil - Fin Type	Louvered	Louvered	Louvered	Louvered
Tube Type	MicroChannel	MicroChannel	MicroChannel	MicroChannel
MicroChannel Depth in. [mm]	0.472 [12]	0.709 [18]	0.709 [18]	0.709 [18]
Face Area sq. ft. [sq. m]	7.19 [0.67]	7.06 [0.66]	9.78 [0.91]	9.78 [0.91]
Rows / FPI [FPcm]	1 / 23 [9]	1 / 23 [9]	1 / 23 [9]	1 / 23 [9]
Indoor Coil - Fin Type	Louvered	Louvered	Louvered	Louvered
Tube Type	MicroChannel	MicroChannel	MicroChannel	MicroChannel
MicroChannel Depth in. [mm]	1 [25.4]	1 [25.4]	1 [25.4]	1 [25.4]
Face Area sq. ft. [sq. m]	3.54 [0.33]	3.54 [0.33]	3.54 [0.33]	3.54 [0.33]
Rows / FPI [FPcm]	1 / 20 [8]	1 / 20 [8]	1 / 20 [8]	1 / 20 [8]
Refrigerant Control	TX Valves	TX Valves	TX Valves	TX Valves
Drain Connection No./Size in. [mm]	1/0.75 [19.05]	1/0.75 [19.05]	1/0.75 [19.05]	1/0.75 [19.05]
Outdoor Fan - Type	Propeller	Propeller	Propeller	Propeller
No. Used/Diameter in. [mm]	1/22 [558.8]	1/22 [558.8]	1/22 [558.8]	1/22 [558.8]
Drive Type/No. Speeds	Direct/1	Direct/1	Direct/1	Direct/1
CFM [L/s]	2500 [1180]	2400 [1133]	3250 [1534]	3250 [1534]
No. Motors/HP	1 at 1/3 HP	1 at 1/3 HP	1 at 1/3 HP	1 at 1/3 HP
Motor RPM	825	825	825	825
Indoor Fan - Type	FC Centrifugal	FC Centrifugal	FC Centrifugal	FC Centrifugal
No. Used/Diameter in. [mm]	1/10x9 [254x229]	1/10x9 [254x229]	1/12x9 [305x229]	1/12x9 [305x229]
Drive Type	Direct	Direct	Direct	Direct
No. Speeds	Multiple	Multiple	Multiple	Multiple
No. Motors	1	1	1	1
Motor HP	1/3	1/2	1	1
Motor RPM	1050	1050	1050	1050
Motor Frame Size	48	48	48	48
Filter - Type	Field Supplied	Field Supplied	Field Supplied	Field Supplied
Furnished	No	No	No	No
(NO.) Size Recommended in. [mm x mm x mm]	(1)1x24x24 [25x610x610]	(1)1x24x24 [25x610x610]	(1)1x24x24 [25x610x610]	(1)1x24x24 [25x610x610]
Refrigerant Charge Oz. [g]	45.6 [1293]	48 [1361]	49.6 [1406]	49.6 [1406]
Weights				
Net Weight lbs. [kg]	354 [161]	354 [161]	363 [165]	363 [165]
Ship Weight lbs. [kg]	362 [164]	362 [164]	371 [168]	371 [168]

NOTES:

- Cooling Performance is rated at 95°F ambient, 80°F entering dry bulb, 67°F entering wet bulb. Gross capacity does not include the effect of fan motor heat. ARI capacity is net and includes the effect of fan motor heat. Units are suitable for operation to ±20% of nominal cfm. Units are certified in accordance with the Unitary Air Conditioner Equipment certification program, which is based on ARI Standard 210/240.
- EER2 and/or SEER2 are rated at ARI conditions and in accordance with DOE test procedures for 1-Phase models. EER and/or SEER are rated at ARI conditions and in accordance with DOE test procedures for 3-Phase models.
- Outdoor Sound Rating shown is tested in accordance with ARI Standard 270.

GENERAL DATA - RACAZR MODELS

NOMINAL SIZES 2-5 TONS [7-17.6 kW]

Model RACAZR Series	036AJT	042ACT	042AJT	048ACT
Cooling Performance¹				Continued ->
Gross Cooling Capacity Btu [kW]	35,600 [10.43]	42,000 [12.31]	42,500 [12.45]	48,000 [14.06]
EER/SEER ²	10.6/13.4	11/14	10.6/13.4	11/14
Nominal CFM/AHRI Rated CFM [L/s]	1200/1180 [566/557]	1400/1510 [661/713]	1400/1510 [661/713]	1600/1730 [755/816]
AHRI Net Cooling Capacity Btu [kW]	34,200 [10.02]	40,500 [11.87]	40,500 [11.87]	46,000 [13.48]
Net Sensible Capacity Btu [kW]	24,900 [7.3]	30,500 [8.94]	30,500 [8.94]	34,000 [9.96]
Net Latent Capacity Btu [kW]	9,300 [2.72]	10,000 [2.93]	10,000 [2.93]	12,000 [3.52]
Net System Power kW	2.98	3.45	3.6	4.11
Compressor				
No./Type	1/Scroll	1/Scroll	1/Scroll	1/Scroll
Outdoor Sound Rating (dB)⁵	75	77	77	76
Outdoor Coil - Fin Type	Louvered	Louvered	Louvered	Louvered
Tube Type	MicroChannel	MicroChannel	MicroChannel	MicroChannel
MicroChannel Depth in. [mm]	0.709 [18]	0.709 [18]	0.709 [18]	1 [25.4]
Face Area sq. ft. [sq. m]	9.78 [0.91]	16.18 [1.5]	16.18 [1.5]	15.37 [1.43]
Rows / FPI [FPcm]	1 / 23 [9]	1 / 23 [9]	1 / 23 [9]	1 / 23 [9]
Indoor Coil - Fin Type	Louvered	Louvered	Louvered	Louvered
Tube Type	MicroChannel	MicroChannel	MicroChannel	MicroChannel
MicroChannel Depth in. [mm]	1 [25.4]	1.26 [32]	1.26 [32]	1.26 [32]
Face Area sq. ft. [sq. m]	3.54 [0.33]	3.98 [0.37]	3.98 [0.37]	3.98 [0.37]
Rows / FPI [FPcm]	1 / 20 [8]	1 / 20 [8]	1 / 20 [8]	1 / 20 [8]
Refrigerant Control	TX Valves	TX Valves	TX Valves	TX Valves
Drain Connection No./Size in. [mm]	1/0.75 [19.05]	1/0.75 [19.05]	1/0.75 [19.05]	1/0.75 [19.05]
Outdoor Fan - Type	Propeller	Propeller	Propeller	Propeller
No. Used/Diameter in. [mm]	1/22 [558.8]	1/22 [558.8]	1/22 [558.8]	1/22 [558.8]
Drive Type/No. Speeds	Direct/1	Direct/1	Direct/1	Direct/1
CFM [L/s]	3250 [1534]	4300 [2029]	4300 [2029]	4150 [1958]
No. Motors/HP	1 at 1/3 HP	1 at 1/3 HP	1 at 1/3 HP	1 at 1/3 HP
Motor RPM	825	1050	1050	1050
Indoor Fan - Type	FC Centrifugal	FC Centrifugal	FC Centrifugal	FC Centrifugal
No. Used/Diameter in. [mm]	1/12x9 [305x229]	1/12x9 [305x229]	1/12x9 [305x229]	1/12x9 [305x229]
Drive Type	Direct	Direct	Direct	Direct
No. Speeds	Multiple	Multiple	Multiple	Multiple
No. Motors	1	1	1	1
Motor HP	1	3/4	3/4	1
Motor RPM	1050	1050	1050	1050
Motor Frame Size	48	48	48	48
Filter - Type	Field Supplied	Field Supplied	Field Supplied	Field Supplied
Furnished	No	No	No	No
(NO.) Size Recommended in. [mm x mm x mm]	(1)1x24x24 [25x610x610]	(1)1x24x24 [25x610x610]	(1)1x24x24 [25x610x610]	(1)1x24x24 [25x610x610]
Refrigerant Charge Oz. [g]	49.6 [1406]	72 [2041]	72 [2041]	88 [2495]
Weights				
Net Weight lbs. [kg]	363 [165]	428 [194]	428 [194]	447 [203]
Ship Weight lbs. [kg]	371 [168]	436 [198]	436 [198]	455 [206]

NOTES:

- Cooling Performance is rated at 95°F ambient, 80°F entering dry bulb, 67°F entering wet bulb. Gross capacity does not include the effect of fan motor heat. ARI capacity is net and includes the effect of fan motor heat. Units are suitable for operation to ±20% of nominal cfm. Units are certified in accordance with the Unitary Air Conditioner Equipment certification program, which is based on ARI Standard 210/240.
- EER2 and/or SEER2 are rated at ARI conditions and in accordance with DOE test procedures for 1-Phase models. EER and/or SEER are rated at ARI conditions and in accordance with DOE test procedures for 3-Phase models.
- Outdoor Sound Rating shown is tested in accordance with ARI Standard 270.

GENERAL DATA - RACAZR MODELS

NOMINAL SIZES 2-5 TONS [7-17.6 kW]

Model RACAZR Series	048ADT	048AJT	060ACT	060ADT
Cooling Performance ¹				Continued ->
Gross Cooling Capacity Btu [kW]	48,000 [14.06]	48,500 [14.21]	58,000 [16.99]	58,000 [16.99]
EER/SEER ²	11/14	10.6/13.4	11/14	11/14
Nominal CFM/AHRI Rated CFM [L/s]	1600/1730 [755/816]	1600/1730 [755/816]	2000/1700 [944/802]	2000/1700 [944/802]
AHRI Net Cooling Capacity Btu [kW]	46,000 [13.48]	46,000 [13.48]	56,000 [16.41]	56,000 [16.41]
Net Sensible Capacity Btu [kW]	34,000 [9.96]	34,000 [9.96]	40,000 [11.72]	40,000 [11.72]
Net Latent Capacity Btu [kW]	12,000 [3.52]	12,000 [3.52]	16,000 [4.69]	16,000 [4.69]
Net System Power kW	4.11	4.33	5.02	5.02
Compressor				
No./Type	1/Scroll	1/Scroll	1/Scroll	1/Scroll
Outdoor Sound Rating (dB) ⁵	76	76	77	77
Outdoor Coil - Fin Type	Louvered	Louvered	Louvered	Louvered
Tube Type	MicroChannel	MicroChannel	MicroChannel	MicroChannel
MicroChannel Depth in. [mm]	1 [25.4]	1 [25.4]	1 [25.4]	1 [25.4]
Face Area sq. ft. [sq. m]	15.37 [1.43]	15.37 [1.43]	15.37 [1.43]	15.37 [1.43]
Rows / FPI [FPcm]	1 / 23 [9]	1 / 23 [9]	1 / 23 [9]	1 / 23 [9]
Indoor Coil - Fin Type	Louvered	Louvered	Louvered	Louvered
Tube Type	MicroChannel	MicroChannel	MicroChannel	MicroChannel
MicroChannel Depth in. [mm]	1.26 [32]	1.26 [32]	1.26 [32]	1.26 [32]
Face Area sq. ft. [sq. m]	3.98 [0.37]	3.98 [0.37]	3.96 [0.37]	3.96 [0.37]
Rows / FPI [FPcm]	1 / 20 [8]	1 / 20 [8]	1 / 20 [8]	1 / 20 [8]
Refrigerant Control	TX Valves	TX Valves	TX Valves	TX Valves
Drain Connection No./Size in. [mm]	1/0.75 [19.05]	1/0.75 [19.05]	1/0.75 [19.05]	1/0.75 [19.05]
Outdoor Fan - Type	Propeller	Propeller	Propeller	Propeller
No. Used/Diameter in. [mm]	1/22 [558.8]	1/22 [558.8]	1/22 [558.8]	1/22 [558.8]
Drive Type/No. Speeds	Direct/1	Direct/1	Direct/1	Direct/1
CFM [L/s]	4150 [1958]	4150 [1958]	4300 [2029]	4300 [2029]
No. Motors/HP	1 at 1/3 HP	1 at 1/3 HP	1 at 1/2 HP	1 at 1/2 HP
Motor RPM	1050	1050	1050	1050
Indoor Fan - Type	FC Centrifugal	FC Centrifugal	FC Centrifugal	FC Centrifugal
No. Used/Diameter in. [mm]	1/12x9 [305x229]	1/12x9 [305x229]	1/12x9 [305x229]	1/12x9 [305x229]
Drive Type	Direct	Direct	Direct	Direct
No. Speeds	Multiple	Multiple	Multiple	Multiple
No. Motors	1	1	1	1
Motor HP	1	1	1	1
Motor RPM	1050	1050	1050	1050
Motor Frame Size	48	48	48	48
Filter - Type	Field Supplied	Field Supplied	Field Supplied	Field Supplied
Furnished	No	No	No	No
(NO.) Size Recommended in. [mm x mm x mm]	(1)1x24x24 [25x610x610]	(1)1x24x24 [25x610x610]	(1)1x24x24 [25x610x610]	(1)1x24x24 [25x610x610]
Refrigerant Charge Oz. [g]	88 [2495]	88 [2495]	89.6 [2540]	89.6 [2540]
Weights				
Net Weight lbs. [kg]	447 [203]	447 [203]	450 [204]	450 [204]
Ship Weight lbs. [kg]	455 [206]	455 [206]	458 [208]	458 [208]

NOTES:

- Cooling Performance is rated at 95°F ambient, 80°F entering dry bulb, 67°F entering wet bulb. Gross capacity does not include the effect of fan motor heat. ARI capacity is net and includes the effect of fan motor heat. Units are suitable for operation to ±20% of nominal cfm. Units are certified in accordance with the Unitary Air Conditioner Equipment certification program, which is based on ARI Standard 210/240.
- EER2 and/or SEER2 are rated at ARI conditions and in accordance with DOE test procedures for 1-Phase models. EER and/or SEER are rated at ARI conditions and in accordance with DOE test procedures for 3-Phase models.
- Outdoor Sound Rating shown is tested in accordance with ARI Standard 270.

GENERAL DATA - RACAZR MODELS

NOMINAL SIZES 2-5 TONS [7-17.6 kW]

Model RACAZR Series	060AJT
Cooling Performance¹	
Gross Cooling Capacity Btu [kW]	58,500 [17.14]
EER/SEER ²	10.6/13.4
Nominal CFM/AHRI Rated CFM [L/s]	2000/1700 [944/802]
AHRI Net Cooling Capacity Btu [kW]	56,000 [16.41]
Net Sensible Capacity Btu [kW]	40,000 [11.72]
Net Latent Capacity Btu [kW]	16,000 [4.69]
Net System Power kW	5.16
Compressor	
No./Type	1/Scroll
Outdoor Sound Rating (dB)⁵	
	77
Outdoor Coil - Fin Type	
Tube Type	Louvered
MicroChannel Depth in. [mm]	1 [25.4]
Face Area sq. ft. [sq. m]	15.37 [1.43]
Rows / FPI [FPcm]	1 / 23 [9]
Indoor Coil - Fin Type	
Tube Type	Louvered
MicroChannel Depth in. [mm]	1.26 [32]
Face Area sq. ft. [sq. m]	3.96 [0.37]
Rows / FPI [FPcm]	1 / 20 [8]
Refrigerant Control	TX Valves
Drain Connection No./Size in. [mm]	1/0.75 [19.05]
Outdoor Fan - Type	
No. Used/Diameter in. [mm]	Propeller 1/22 [558.8]
Drive Type/No. Speeds	Direct/1
CFM [L/s]	4300 [2029]
No. Motors/HP	1 at 1/2 HP
Motor RPM	1050
Indoor Fan - Type	
No. Used/Diameter in. [mm]	F C Centrifugal 1/12x9 [305x229]
Drive Type	Direct
No. Speeds	Multiple
No. Motors	1
Motor HP	1
Motor RPM	1050
Motor Frame Size	48
Filter - Type	
Furnished	Field Supplied
(NO.) Size Recommended in. [mm x mm x mm]	No (1)1x24x24 [25x610x610]
Refrigerant Charge Oz. [g]	89.6 [2540]
Weights	
Net Weight lbs. [kg]	450 [204]
Ship Weight lbs. [kg]	458 [208]

NOTES:

- Cooling Performance is rated at 95°F ambient, 80°F entering dry bulb, 67°F entering wet bulb. Gross capacity does not include the effect of fan motor heat. ARI capacity is net and includes the effect of fan motor heat. Units are suitable for operation to ±20% of nominal cfm. Units are certified in accordance with the Unitary Air Conditioner Equipment certification program, which is based on ARI Standard 210/240.
- EER2 and/or SEER2 are rated at ARI conditions and in accordance with DOE test procedures for 1-Phase models. EER and/or SEER are rated at ARI conditions and in accordance with DOE test procedures for 3-Phase models.
- Outdoor Sound Rating shown is tested in accordance with ARI Standard 270.

XX. ELECTRICAL DATA

ELECTRICAL DATA - RACAZR SERIES										
		024AJT	030AJT	036ACT	036ADT	036AJT	042ACT	042AJT	048ACT	048ADT
Unit Information	Unit Operating Voltage Range	187-253	187-253	187-253	414-506	187-253	187-253	187-253	187-253	414-506
	Volts	208/230	208/230	208/230	460	208/230	208/230	208/230	208/230	460
	Phase	1	1	3	3	1	3	1	3	3
	Hz	60	60	60	60	60	60	60	60	60
	Minimum Circuit Ampacity	18	21	20	10	28	22	28	26	13
	Minimum Overcurrent Protection Device Size	25	25	25	15	35	25	35	30	15
	Maximum Overcurrent Protection Device Size	25	30	25	15	40	30	40	35	15
Compressor Motor	No.	1	1	1	1	1	1	1	1	1
	Volts	208/230	208/230	208/230	460	208/230	208/230	208/230	208/230	460
	Phase	1	1	3	3	1	3	1	3	3
	RPM	3500	3500	3500	3500	3500	3500	3500	3500	3500
	HP, Compressor 1									
	Amps (RLA), Comp. 1	10.8	12.3	8.5	3.8	14.7	10.6	15.9	12.6	6
	Amps (LRA), Comp. 1	55	63	70	31	75	118	112.3	123	60
	HP, Compressor 2									
	Amps (RLA), Comp. 2									
Amps (LRA), Comp. 2										
Condenser Motor	No.	1	1	1	1	1	1	1	1	1
	Volts	208/230	208/230	208/230	460	208/230	208/230	208/230	208/230	460
	Phase	1	1	1	1	1	1	1	1	1
	HP	1/3	1/3	1/3	1/3	1/3	1/3	1/3	1/3	1/3
	Amps (FLA, each)	1.5	1.5	1.5	0.8	1.5	2	2	2	1
	Amps (LRA, each)	3	3	3	1.6	3	3.9	3.9	3.9	2.2
Evaporator Fan	No.	1	1	1	1	1	1	1	1	1
	Volts	208/230	208/230	208/230	460	208/230	208/230	208/230	208/230	460
	Phase	1	1	1	1	1	1	1	1	1
	HP	1/3	1/2	1	1	1	3/4	3/4	1	1
	Amps (FLA, each)	2.8	4.1	7.6	4	7.6	6	6	7.6	4
	Amps (LRA, each)									

ELECTRICAL DATA - RACAZR SERIES					
		048AJT	060ACT	060ADT	060AJT
Unit Information	Unit Operating Voltage Range	187-253	187-253	414-506	187-253
	Volts	208/230	208/230	460	208/230
	Phase	1	3	3	1
	Hz	60	60	60	60
	Minimum Circuit Ampacity	36	29	14	41
	Minimum Overcurrent Protection Device Size	45	35	15	50
	Maximum Overcurrent Protection Device Size	50	40	15	60
Compressor Motor	No.	1	1	1	1
	Volts	208/230	208/230	460	208/230
	Phase	1	3	3	1
	RPM	3500	3500	3500	3500
	HP, Compressor 1				
	Amps (RLA), Comp. 1	19.9	14	6.5	23.5
	Amps (LRA), Comp. 1	109	93	60	118
	HP, Compressor 2				
	Amps (RLA), Comp. 2				
Amps (LRA), Comp. 2					
Condenser Motor	No.	1	1	1	1
	Volts	208/230	208/230	460	208/230
	Phase	1	1	1	1
	HP	1/3	1/2	1/2	1/2
	Amps (FLA, each)	2	2.3	1.2	2.3
	Amps (LRA, each)	3.9	5.5	3	5.5
Evaporator Fan	No.	1	1	1	1
	Volts	208/230	208/230	460	208/230
	Phase	1	1	1	1
	HP	1	1	1	1
	Amps (FLA, each)	8.9	8.9	4	8.9
	Amps (LRA, each)				

XXI. AIRFLOW PERFORMANCE

INDOOR AIRFLOW PERFORMANCE FOR 2-5 TON PACKAGED AIR CONDITIONER: RACA-DIRECT DRIVE WITH CONSTANT TORQUE MOTOR

INDOOR AIRFLOW PERFORMANCE RACAZR - (208/230V, 1-PHASE) CONSTANT TORQUE MOTOR

NOMINAL COOLING CAPACITY (TONS) [KW]	MOTOR SPEED FROM FACTORY		RECOMMENDED SPEED TAP FOR FIELD INSTALLED HEATER KIT.	MANUFACTURER RECOMMENDED COOLING AIRFLOW (MIN/MAX)	BLOWER SIZE/MOTOR HP [W] & # OF SPEEDS	MOTOR TAP / USAGE	EXTERNAL STATIC PRESSURE - INCHES W.C. [KPA] (SIDE DISCHARGE-DRY COIL)											
	COOL	HEAT					0.1 [0.02]	0.2 [0.05]	0.3 [0.07]	0.4 [0.10]	0.5 [0.12]	0.6 [0.15]	0.7 [0.17]	0.8 [0.20]	0.9 [0.22]	1.0 [0.25]		
2.0 [7.03]	TAP 3	HEAT	5 KW - TAP 1 8 KW - TAP 1 10 KW - TAP 2	700 CFM / 900 CFM	10X9 BLOWER 1/3 HP [249] 5 SPEED (CONSTANT TORQUE)	TAP 3 - LOW STATIC COOL	CFM	757	651	570	488	414	335	251	201	144		
							WATTS	591	633	700	767	814	858	899	944	985	1032	
							CFM	855	801	746	683	619	519	473	406	354	329	
							RPM	639	691	748	806	855	921	953	994	1034	1061	
							WATTS	90	96	102	109	115	123	126	131	136	140	
	TAP 2	COOL	HEAT	5 KW - TAP 1 8 KW - TAP 1 10 KW - TAP 2	700 CFM / 900 CFM	10X9 BLOWER 1/3 HP [249] 5 SPEED (CONSTANT TORQUE)	TAP 2 - ELEC. HEAT	CFM	876	824	774	703	629	558	496	447	392	349
								WATTS	660	699	753	816	866	925	964	997	1037	1067
								CFM	96	101	108	114	121	128	133	137	143	146
								RPM	1020	979	933	883	837	731	714	655	606	542
								WATTS	725	771	819	867	911	983	1025	1065	1096	1130
2.5 [8.79]	TAP 3	HEAT	5 KW - TAP 1 8 KW - TAP 1 10 KW - TAP 2	875 CFM / 1125 CFM	10X9 BLOWER 1/2 HP [372] 5 SPEED (CONSTANT TORQUE)	TAP 3 - LOW STATIC COOL	CFM	1330	1294	1256	1220	1183	1145	1078	958	790	699	
							WATTS	886	911	952	990	1029	1069	1103	1127	1143	1156	
							CFM	270	275	286	294	305	314	311	286	266	242	
							RPM	830	874	909	947	981	1028	1070	1112	1153	1165	
							WATTS	511	536	566	596	626	656	686	716	746	776	
	TAP 2	COOL	HEAT	5 KW - TAP 1 8 KW - TAP 1 10 KW - TAP 2	875 CFM / 1125 CFM	10X9 BLOWER 1/2 HP [372] 5 SPEED (CONSTANT TORQUE)	TAP 2 - ELEC. HEAT	CFM	591	636	696	760	810	858	892	942	982	1019
								WATTS	68	69	73	80	85	89	91	96	100	102
								CFM	860	800	742	676	558	493	431	371	330	296
								RPM	630	693	748	809	851	907	949	987	1020	1059
								WATTS	88	93	101	108	114	120	125	129	133	137
3.0 [10.55]	TAP 3	HEAT	5 KW - TAP 1 8 KW - TAP 1 10 KW - TAP 2 15 KW - TAP 2	1050 CFM / 1350 CFM	12X9T BLOWER 1 HP [746] 5 SPEED (CONSTANT TORQUE)	TAP 3 - LOW STATIC COOL	CFM	1222	1177	1145	1098	1064	1017	980	936	833	701	
							WATTS	830	874	909	947	981	1028	1070	1112	1153	1165	
							CFM	1631	1583	1537	1480	1406	1322	1216	1056	905	827	
							RPM	1049	1080	1095	1111	1123	1136	1146	1158	1168	1170	
							WATTS	465	474	466	456	435	412	377	329	286	266	
	TAP 2	COOL	HEAT	5 KW - TAP 1 8 KW - TAP 1 10 KW - TAP 2 15 KW - TAP 2	1050 CFM / 1350 CFM	12X9T BLOWER 1 HP [746] 5 SPEED (CONSTANT TORQUE)	TAP 2 - ELEC. HEAT	CFM	969	802	692	558	460	396	326	283	252	188
								WATTS	589	603	678	717	766	791	818	855	886	911
								CFM	106	93	101	106	117	117	120	125	130	133
								RPM	1105	1050	1005	894	827	762	695	618	554	488
								WATTS	644	690	729	804	848	879	908	944	968	990
3.0 [10.55]	TAP 3	HEAT	5 KW - TAP 1 8 KW - TAP 1 10 KW - TAP 2 15 KW - TAP 2	1050 CFM / 1350 CFM	12X9T BLOWER 1 HP [746] 5 SPEED (CONSTANT TORQUE)	TAP 3 - LOW STATIC COOL	CFM	143	151	159	169	180	188	193	200	204	209	
							WATTS	1321	1277	1237	1189	1152	1039	984	931	871	808	
							CFM	738	774	808	846	876	957	990	1022	1047	1073	
							RPM	222	231	240	249	257	280	287	295	302	309	
							WATTS	1476	1439	1406	1378	1331	1295	1186	1134	1086	1037	
	TAP 2	COOL	HEAT	5 KW - TAP 1 8 KW - TAP 1 10 KW - TAP 2 15 KW - TAP 2	1050 CFM / 1350 CFM	12X9T BLOWER 1 HP [746] 5 SPEED (CONSTANT TORQUE)	TAP 4 - MED STATIC COOL*	CFM	809	843	872	901	937	964	1045	1076	1107	1139
								WATTS	298	308	318	330	339	349	374	385	398	406
								CFM	1574	1538	1469	1401	1366	1268	1205	1125	1138	1149
								RPM	859	890	921	951	1009	1110	1138	1149	1138	1149
								WATTS	362	372	384	396	407	417	427	456	460	446

NOTES:
 (1) FOR CONSTANT TORQUE MOTORS: USE MOTOR TAPS 3-5 TO ACHIEVE RATED AIRFLOW AT AHRI MINIMUM EXTERNAL STATIC PRESSURE.
 (A) USE * MARKED TAP FOR AHRI 210/240-2023
 (B) USE ** MARKED TAP FOR AHRI 210/240-2017

(2) GRAYED OUT PORTIONS NOT RECOMMENDED FOR USE IN FIELD.

DOWN DISCHARGE PRESSURE DROP (ADD TO EXTERNAL STATIC PRESSURE)					
CFM [L/S]	800 [378]	1000 [472]	1400 [661]	1800 [849]	2000 [944]
PRESSURE DROP - INCHES W.C. [KPA]	.02 [0.05]	.05 [0.12]	.1 [0.25]	.15 [0.37]	.17 [0.42]

INDOOR AIRFLOW PERFORMANCE FOR 2-5 TON PACKAGED AIR CONDITIONER: RACA-DIRECT DRIVE WITH CONSTANT TORQUE MOTOR

INDOOR AIRFLOW PERFORMANCE RACAZR - (208/230V, 1-PHASE) CONSTANT TORQUE MOTOR

NOMINAL COOLING CAPACITY TONS [KW]	MOTOR SPEED FROM FACTORY		RECOMMENDED SPEED TAP FOR FIELD INSTALLED HEATER KIT.	MANUFACTURER RECOMMENDED AIRFLOW (MIN/MAX)	BLOWER SIZE/ MOTOR HP (W/ # OF SPEEDS)	MOTOR TAP / USAGE	EXTERNAL STATIC PRESSURE - INCHES W.C. [KPA] (SIDE DISCHARGE-DRY COIL)											
	COOL	HEAT					0.1 [0.2]	0.2 [0.05]	0.3 [0.07]	0.4 [0.10]	0.5 [0.12]	0.6 [0.15]	0.7 [0.17]	0.8 [0.20]	0.9 [0.22]	1.0 [0.25]		
3.5 [12.31]	TAP 3	COOL	TAP 2	5 KW - TAP 1 8 KW - TAP 1 10 KW - TAP 2 15 KW - TAP 2	1225 CFM/ 1575 CFM	12X9T BLOWER 3/4 HP [559] 3 SPEED (CONSTANT TORQUE)	TAP 1 - FAN	CFM	1103	1050	959	872	803	725	654	558	482	415
							WATTS	612	651	715	795	837	908	937	908	937	952	
							TAP 2 - ELEC. HEAT	CFM	1448	1402	1358	1313	1227	1164	1122	1058	1004	936
							WATTS	750	780	844	906	946	967	1000	1032	1064		
							WATTS	256	265	274	283	302	313	320	329	340	351	
	WATTS	1576	1532	1493	1452	1414	1311	1258	1223	1160	1114							
	TAP 3	HEAT	TAP 2	8 KW - TAP 1 10 KW - TAP 2 15 KW - TAP 2	1225 CFM/ 1575 CFM	12X9T BLOWER 3/4 HP [559] 3 SPEED (CONSTANT TORQUE)	TAP 3 - LOW STAGE COOL	CFM	804	832	861	888	918	984	1019	1039	1070	1095
							WATTS	321	330	340	348	359	382	393	401	412	421	
							TAP 4 - MED STAGE COOL*	CFM	1734	1693	1644	1619	1582	1540	1463	1390	1312	1200
							WATTS	867	896	917	939	967	992	1048	1092	1114	1130	
WATTS							411	422	430	437	449	459	483	499	496	480		
TAP 3	HEAT	TAP 2	8 KW - TAP 1 10 KW - TAP 2 15 KW - TAP 2	1225 CFM/ 1575 CFM	12X9T BLOWER 3/4 HP [559] 3 SPEED (CONSTANT TORQUE)	TAP 5 - HIGH STAGE COOL	CFM	1860	1824	1792	1728	1691	1652	1495	1362	1258		
						WATTS	929	951	977	997	1023	1049	1071	1121	1134	1140		
						TAP 5 - HIGH STAGE COOL	CFM	509	519	533	541	554	566	577	560	530	504	
						WATTS	1211	1050	935	837	755	694	622	535	475	426		
						WATTS	588	591	636	690	728	756	788	829	861	889		
4.0 [14.07]	LOW STAGE - TAP 3 HIGH STAGE - TAP 4	COOL	TAP 2	1400 CFM/ 1800 CFM	12X9R BLOWER 1 HP [746] 5 SPEED (CONSTANT TORQUE)	TAP 1 - FAN	CFM	1453	1400	1360	1304	1239	1155	1097	1036	987	921	
						WATTS	670	705	734	770	813	860	892	926	947	975		
						TAP 3 - LOW STAGE COOL	CFM	215	226	233	243	255	268	277	286	292	300	
						WATTS	1404	1362	1311	1254	1168	1100	1026	976	914	860		
						WATTS	656	687	721	760	809	849	887	914	937	961		
	TAP 3	HEAT	TAP 2	8 KW - TAP 1 10 KW - TAP 2 15 KW - TAP 2	1400 CFM/ 1800 CFM	12X9R BLOWER 1 HP [746] 5 SPEED (CONSTANT TORQUE)	TAP 4 - HIGH STAGE COOL MED STAGE	CFM	200	209	218	227	241	251	260	268	274	280
							WATTS	1800	1759	1723	1687	1625	1577	1516	1465	1418	1370	
							TAP 5 - HIGH STAGE COOL *	CFM	866	889	916	937	974	1001	1035	1063	1088	1112
							WATTS	400	408	419	429	445	456	470	481	492	506	
							WATTS	2048	2007	1977	1929	1896	1856	1823	1773	1725	1671	
TAP 3	HEAT	TAP 2	8 KW - TAP 1 10 KW - TAP 2 15 KW - TAP 2	1400 CFM/ 1800 CFM	12X9R BLOWER 1 HP [746] 5 SPEED (CONSTANT TORQUE)	TAP 5 - HIGH STAGE COOL *	CFM	966	983	1013	1041	1061	1085	1105	1133	1164	1181	
						WATTS	587	603	615	629	640	654	665	680	696	708		
						TAP 1 - FAN	CFM	1132	1056	997	903	834	785	701	641	570	519	
						WATTS	661	696	725	778	802	825	862	888	926	947		
						WATTS	136	143	148	159	162	168	177	180	189	198		
5.0 [17.59]	LOW STAGE - TAP 3 HIGH STAGE - TAP 4	COOL	TAP 2	1750 CFM/ 2250 CFM	12X9R BLOWER 1 HP [746] 5 SPEED (CONSTANT TORQUE)	TAP 2 - ELEC. HEAT	CFM	1448	1403	1329	1274	1220	1158	1097	1029	973	932	
						WATTS	781	811	846	871	900	934	963	987	1007	1021		
						TAP 3 - LOW STAGE COOL	CFM	251	258	266	273	282	293	303	309	319	326	
						WATTS	1476	1424	1349	1299	1242	1165	1106	1053	1001	962		
						WATTS	788	819	861	885	913	947	974	998	1018	1028		
	TAP 3	HEAT	TAP 2	8 KW - TAP 1 10 KW - TAP 2 15 KW - TAP 2	1750 CFM/ 2250 CFM	12X9R BLOWER 1 HP [746] 5 SPEED (CONSTANT TORQUE)	TAP 4 - HIGH STAGE COOL* MED STAGE	CFM	258	264	280	287	295	305	313	321	331	337
							WATTS	1985	1954	1916	1865	1831	1784	1744	1704	1663	1626	
							TAP 5 - HIGH STAGE COOL	CFM	997	1021	1044	1078	1099	1122	1143	1166	1186	1207
							WATTS	599	612	624	640	652	666	677	689	700	711	
							WATTS	2226	2192	2160	2128	2086	2051	2010	1954	1921	1883	
TAP 3	HEAT	TAP 2	8 KW - TAP 1 10 KW - TAP 2 15 KW - TAP 2	1750 CFM/ 2250 CFM	12X9R BLOWER 1 HP [746] 5 SPEED (CONSTANT TORQUE)	TAP 5 - HIGH STAGE COOL	CFM	1074	1101	1120	1138	1166	1187	1209	1240	1256	1274	
						WATTS	815	833	845	857	875	891	904	926	936	949		

NOTES:
 (1) FOR CONSTANT TORQUE MOTORS: USE MOTOR TAPS 3-5 TO ACHIEVE RATED AIRFLOW AT AHRI MINIMUM EXTERNAL STATIC PRESSURE.
 (A) USE * MARKED TAP FOR AHRI 210/240-2023
 (B) USE ** MARKED TAP FOR AHRI 210/240-2017

(2) GRAYED OUT PORTIONS NOT RECOMMENDED FOR USE IN FIELD.

DOWN DISCHARGE PRESSURE DROP (ADD TO EXTERNAL STATIC PRESSURE)					
CFM [L/S]	800 [378]	1000 [472]	1200 [566]	1400 [661]	2000 [944]
PRESSURE DROP - INCHES W.C. [KPA]	.02 [.005]	.05 [.012]	.07 [.017]	.1 [.025]	.17 [.042]

INDOOR AIRFLOW PERFORMANCE FOR 2-5 TON PACKAGED AIR CONDITIONER: RACA-DIRECT DRIVE WITH CONSTANT TORQUE MOTOR

INDOOR AIRFLOW PERFORMANCE RACAZR - (208/230V, 3-PHASE) CONSTANT TORQUE MOTOR

NOMINAL COOLING CAPACITY TONS [KW]	MOTOR SPEED FROM FACTORY		RECOMMENDED SPEED TAP FOR FIELD INSTALLED HEATER KIT.	MANUFACTURER RECOMMENDED COOLING AIRFLOW (MIN/ MAX)	BLOWER SIZE/ MOTOR HP [W] & # OF SPEEDS	MOTOR TAP / USAGE	EXTERNAL STATIC PRESSURE - INCHES W.C. [KPA] (SIDE DISCHARGE-DRY COIL)															
							0.1 [0.2]	0.2 [0.05]	0.3 [0.07]	0.4 [-10]	0.5 [-12]	0.6 [-15]	0.7 [-17]	0.8 [20]	0.9 [22]	1.0 [25]						
							CFM	CFM	CFM	CFM	CFM	CFM	CFM	CFM	CFM	CFM	CFM					
3 [10.55]	TAP 3	HEAT	5 KW - TAP 1 8 KW - TAP 1 10 KW - TAP 2 15 KW - TAP 2	1050 CFM / 1350 CFM	12X9T BLOWER 1 HP [746] 3 SPEED (CONSTANT TORQUE)	TAP 1 - FAN	969	802	692	558	460	396	326	293	252	188						
							589	603	678	717	766	791	818	855	886	911						
							106	93	101	106	112	117	120	125	130	133						
							CFM	CFM	CFM	CFM	CFM	CFM	CFM	CFM	CFM	CFM	CFM					
							644	690	729	804	848	879	908	944	968	990						
	TAP 2	TAP 3	HEAT	5 KW - TAP 1 8 KW - TAP 1 10 KW - TAP 2 15 KW - TAP 2	1050 CFM / 1350 CFM	12X9T BLOWER 1 HP [746] 3 SPEED (CONSTANT TORQUE)	TAP 3 - LOW STAGE COOL**	143	151	159	169	180	188	193	200	204	209					
								1321	1277	1237	1189	1152	1039	984	931	871	808					
								738	774	808	846	876	957	990	1022	1047	1073					
								CFM	CFM	CFM	CFM	CFM	CFM	CFM	CFM	CFM	CFM	CFM				
								222	231	240	249	257	280	295	302	309	309					
4 [14.07]	LOW STAGE - TAP 3 HIGH STAGE - TAP 4	TAP 2	5 KW - TAP 1 8 KW - TAP 1 10 KW - TAP 2 15 KW - TAP 2	1400 CFM / 1800 CFM	12X9T BLOWER 1 HP [746] 5 SPEED (CONSTANT TORQUE)	TAP 2 - ELEC. HEAT	758	787	814	847	876	944	969	996	1029	1061						
							248	258	264	274	282	302	310	315	327	338						
							1325	1275	1231	1179	1080	1018	967	893	812	748						
							CFM	CFM	CFM	CFM	CFM	CFM	CFM	CFM	CFM	CFM	CFM					
							702	735	766	800	867	902	930	962	985	1031						
	LOW STAGE - TAP 3 HIGH STAGE - TAP 4	TAP 2	TAP 2	5 KW - TAP 1 8 KW - TAP 1 10 KW - TAP 2 15 KW - TAP 2	1400 CFM / 1800 CFM	12X9T BLOWER 1 HP [746] 5 SPEED (CONSTANT TORQUE)	TAP 3 - LOW STAGE COOL**	195	206	212	221	237	245	251	261	268	278					
								1812	1767	1739	1706	1668	1634	1588	1546	1510	1273					
								960	987	1006	1027	1047	1069	1095	1120	1137	1167					
								CFM	CFM	CFM	CFM	CFM	CFM	CFM	CFM	CFM	CFM	CFM				
								458	470	478	488	497	504	518	530	537	485					
5 [17.59]	LOW STAGE - TAP 3 HIGH STAGE - TAP 4	TAP 2	5 KW - TAP 1 8 KW - TAP 1 10 KW - TAP 2 15 KW - TAP 2	1750 CFM / 2250 CFM	12X9R BLOWER 1 HP [746] 5 SPEED (CONSTANT TORQUE)	TAP 1 - FAN	661	696	725	778	802	825	862	888	926	947						
							136	143	148	159	162	168	177	180	189	198						
							1448	1403	1329	1274	1220	1158	1097	1029	973	932						
							CFM	CFM	CFM	CFM	CFM	CFM	CFM	CFM	CFM	CFM	CFM					
							781	811	846	871	900	934	963	987	1007	1021						
	LOW STAGE - TAP 3 HIGH STAGE - TAP 4	TAP 2	TAP 2	5 KW - TAP 1 8 KW - TAP 1 10 KW - TAP 2 15 KW - TAP 2	1750 CFM / 2250 CFM	12X9R BLOWER 1 HP [746] 5 SPEED (CONSTANT TORQUE)	TAP 3 - LOW STAGE COOL**	251	258	266	273	282	293	303	309	319	326					
								1381	1315	1253	1209	1151	1061	1002	937	865	816					
								736	780	812	837	866	907	930	952	980	1005					
								CFM	CFM	CFM	CFM	CFM	CFM	CFM	CFM	CFM	CFM	CFM				
								211	223	232	239	246	258	262	270	277	285					
LOW STAGE - TAP 3 HIGH STAGE - TAP 4	TAP 2	TAP 2	5 KW - TAP 1 8 KW - TAP 1 10 KW - TAP 2 15 KW - TAP 2	1750 CFM / 2250 CFM	12X9R BLOWER 1 HP [746] 5 SPEED (CONSTANT TORQUE)	TAP 4 - HIGH STAGE COOL**	1872	1844	1769	1732	1694	1654	1593	1548	1496	1439						
							943	961	990	1010	1033	1060	1082	1110	1132	1164						
							493	501	505	515	525	539	550	564	573	589						
							CFM	CFM	CFM	CFM	CFM	CFM	CFM	CFM	CFM	CFM	CFM					
							2226	2192	2160	2128	2086	2051	2010	1954	1921	1883						
LOW STAGE - TAP 3 HIGH STAGE - TAP 4	TAP 2	TAP 2	5 KW - TAP 1 8 KW - TAP 1 10 KW - TAP 2 15 KW - TAP 2	1750 CFM / 2250 CFM	12X9R BLOWER 1 HP [746] 5 SPEED (CONSTANT TORQUE)	TAP 5 - HIGH STAGE COOL HIGH	1074	1101	1120	1138	1166	1187	1209	1240	1256	1274						
							815	833	845	857	875	891	904	926	936	949						
							CFM	CFM	CFM	CFM	CFM	CFM	CFM	CFM	CFM	CFM	CFM					
							800	378	1000	472	1600	755	1400	661	1200	566	1400	661	1800	849	2000	944
							CFM [L/S]	CFM [L/S]	CFM [L/S]	CFM [L/S]	CFM [L/S]	CFM [L/S]	CFM [L/S]	CFM [L/S]	CFM [L/S]	CFM [L/S]	CFM [L/S]	CFM [L/S]	CFM [L/S]	CFM [L/S]	CFM [L/S]	CFM [L/S]
PRESSURE DROP - INCHES W.C. [KPA]				.02 [0.005]		.05 [0.012]		.1 [0.025]		.12 [0.030]		.15 [0.037]		.17 [0.042]								

NOTES:
 (1) FOR CONSTANT TORQUE MOTORS: USE MOTOR TAPS 3-5 TO ACHIEVE RATED AIRFLOW AT AHR1 MINIMUM EXTERNAL STATIC PRESSURE.
 (A) USE ** MARKED TAP FOR AHR1 210/240-2023
 (B) USE * MARKED TAP FOR AHR1 210/240-2017

(2) GRAYED OUT PORTIONS NOT RECOMMENDED FOR USE IN FIELD.

DOWN DISCHARGE PRESSURE DROP (ADD TO EXTERNAL STATIC PRESSURE)	
CFM [L/S]	800 [378] 1000 [472] 1600 [755] 1400 [661] 1200 [566] 1800 [849] 2000 [944]
PRESSURE DROP - INCHES W.C. [KPA]	.02 [0.005] .05 [0.012] .1 [0.025] .12 [0.030] .15 [0.037] .17 [0.042]

INDOOR AIRFLOW PERFORMANCE FOR 2-5 TON PACKAGED AIR CONDITIONER: RACA-DIRECT DRIVE WITH CONSTANT TORQUE MOTOR

INDOOR AIRFLOW PERFORMANCE RACAZR - (460V, 3-PHASE) CONSTANT TORQUE MOTOR

NOMINAL COOLING CAPACITY (TONS) [KW]	MOTOR SPEED FROM FACTORY		RECOMMENDED SPEED TAP FOR FIELD INSTALLED HEATER KIT.	MANUFACTURER RECOMMENDED COOLING AIRFLOW (MIN/MAX)	BLOWER SIZE/ MOTOR HP [W] & # OF SPEEDS	MOTOR TAP / USAGE	EXTERNAL STATIC PRESSURE - INCHES W.C. [KPA] (SIDE DISCHARGE-DRY COIL)										
	COOL	HEAT					0.1 [0.2]	0.2 [0.05]	0.3 [0.07]	0.4 [-1.0]	0.5 [-1.2]	0.6 [-1.5]	0.7 [-1.7]	0.8 [2.0]	0.9 [2.2]	1.0 [2.5]	
3 [10.55]	TAP 3	TAP 2	5 KW - TAP 1 8 KW - TAP 1 10 KW - TAP 2 15 KW - TAP 2	1050 CFM / 1350 CFM	12X9T BLOWER 1 HP [746] 3 SPEED (CONSTANT TORQUE)	TAP 1 - FAN	CFM	953	800	711	580	490	419	354	317	298	238
							RPM	584	613	671	720	764	795	844	890	918	918
							WATTS	107	109	111	116	122	127	131	134	142	146
							CFM	1092	1051	999	902	844	768	698	629	567	494
							CFM	646	684	727	803	842	883	913	949	968	998
							CFM	148	156	167	183	192	201	208	215	221	226
	TAP 3 - LOW STAGE COOL**	TAP 2	5 KW - TAP 1 8 KW - TAP 1 10 KW - TAP 2 15 KW - TAP 2	1050 CFM / 1350 CFM	12X9T BLOWER 1 HP [746] 3 SPEED (CONSTANT TORQUE)	TAP 3 - LOW STAGE COOL**	CFM	1315	1274	1241	1197	1138	1065	1015	952	906	840
							RPM	737	774	807	845	893	950	983	1015	1046	1073
							WATTS	234	244	254	265	280	297	307	318	326	335
							CFM										
							RPM										
							WATTS										
4 [14.07]	LOW STAGE - TAP 3 / HIGH STAGE - TAP 4	TAP 2	5 KW - TAP 1 8 KW - TAP 1 10 KW - TAP 2 15 KW - TAP 2	1400 CFM / 1800 CFM	12X9T BLOWER 1 HP [746] 5 SPEED (CONSTANT TORQUE)	TAP 5 - HIGH STAGE COOL**	CFM	1561	1531	1499	1462	1433	1394	1344	1290	1220	1126
							RPM	852	879	908	943	971	1000	1039	1080	1130	1149
							WATTS	370	381	392	405	418	429	446	462	483	470
							CFM	1105	1050	1008	910	838	772	699	608	535	469
							RPM	610	650	684	753	793	829	863	910	939	962
							WATTS	134	143	149	167	172	179	187	197	204	208
	TAP 2 - ELEC. HEAT	TAP 2	5 KW - TAP 1 8 KW - TAP 1 10 KW - TAP 2 15 KW - TAP 2	1400 CFM / 1800 CFM	12X9T BLOWER 1 HP [746] 5 SPEED (CONSTANT TORQUE)	TAP 2 - ELEC. HEAT	CFM	1440	1400	1357	1322	1289	1199	1164	1109	1058	987
							RPM	752	788	825	852	878	945	962	997	1028	1059
							WATTS	262	272	284	294	304	326	332	344	365	365
							CFM	1315	1272	1229	1188	1107	1051	997	931	862	797
							RPM	703	740	775	804	870	899	922	967	996	1025
							WATTS	208	219	229	236	256	264	274	284	292	300
5 [17.59]	LOW STAGE - TAP 3 / HIGH STAGE - TAP 4	TAP 2	5 KW - TAP 1 8 KW - TAP 1 10 KW - TAP 2 15 KW - TAP 2	1750 CFM / 2250 CFM	12X9R BLOWER 1 HP [746] 5 SPEED (CONSTANT TORQUE)	TAP 5 - HIGH STAGE COOL**	CFM	1860	1828	1790	1728	1706	1672	1624	1583	1514	
							RPM	933	957	982	1006	1036	1057	1083	1107	1122	1133
							WATTS	520	536	548	560	575	587	597	611	605	593
							CFM	1101	1051	983	896	825	763	695	621	558	506
							RPM	594	628	668	724	759	790	820	854	888	915
							WATTS	130	137	145	157	164	171	177	186	193	197
	TAP 2 - ELEC. HEAT	TAP 2	5 KW - TAP 1 8 KW - TAP 1 10 KW - TAP 2 15 KW - TAP 2	1750 CFM / 2250 CFM	12X9R BLOWER 1 HP [746] 5 SPEED (CONSTANT TORQUE)	TAP 2 - ELEC. HEAT	CFM	1454	1401	1363	1322	1265	1195	1140	1088	1039	998
							RPM	719	757	787	816	854	898	933	963	985	1005
							WATTS	253	264	274	283	296	311	322	332	340	348
							CFM	1364	1320	1277	1232	1169	1100	1036	980	930	877
							RPM	687	722	754	784	824	870	907	938	953	984
							WATTS	216	227	235	245	257	271	282	290	297	304
TAP 4 - HIGH STAGE COOL**	TAP 2	5 KW - TAP 1 8 KW - TAP 1 10 KW - TAP 2 15 KW - TAP 2	1750 CFM / 2250 CFM	12X9R BLOWER 1 HP [746] 5 SPEED (CONSTANT TORQUE)	TAP 4 - HIGH STAGE COOL**	CFM	1870	1832	1792	1761	1731	1696	1656	1621	1582	1528	
						RPM	885	912	939	963	987	1009	1034	1057	1083	1113	
						WATTS	492	506	521	534	545	555	569	581	593	611	
						CFM	2152	2120	2087	2059	2025	2004	1969	1934	1905	1875	
						RPM	1002	1025	1051	1074	1090	1111	1136	1152	1175	1197	
						WATTS	761	776	791	803	816	828	841	852	865	878	

NOTES:
 (1) FOR CONSTANT TORQUE MOTORS: USE MOTOR TAPS 3-5 TO ACHIEVE RATED AIRFLOW AT AHRI MINIMUM EXTERNAL STATIC PRESSURE.
 (A) USE ** MARKED TAP FOR AHRI 210/240-2023
 (B) USE ** MARKED TAP FOR AHRI 210/240-2017

(2) GRAYED OUT PORTIONS NOT RECOMMENDED FOR USE IN FIELD.

DOWN DISCHARGE PRESSURE DROP (ADD TO EXTERNAL STATIC PRESSURE)						
CFM [L/S]	800 [378]	1000 [472]	1400 [661]	1600 [755]	1800 [849]	2000 [944]
PRESSURE DROP - INCHES W.C. [KPA]	.02 [.005]	.05 [.012]	.1 [.025]	.12 [.030]	.15 [.037]	.17 [.042]

XXII. HEATER KITS CHARACTERISTICS

AUXILIARY ELECTRIC HEATER KITS CHARACTERISTICS AND APPLICATION: RACA-

208/240 VOLT, THREE PHASE, 60 HZ, AUXILIARY ELECTRIC HEATER KITS CHARACTERISTICS AND APPLICATION									
						SEPARATE POWER SUPPLY FOR BOTH UNIT AND HEATER KIT			
RHEEM MODEL NUMBER RACAZR	HEATER KIT			AIR CONDITIONER		HEATER KIT		AIR CONDITIONER	
	RXQJ- HEATER KIT NOMINAL KW	RATED HEATER KW @ 208/240 V	HEATER AMP. @ 208/240 V	UNIT MIN. CKT. AMPACITY @ 208/240 V	OVER CURRENT PROTECTIVE DEVICE SIZE MIN./MAX	MIN. CKT. AMPACITY 208/240V	MAX. FUSE SIZE 208/240V	MIN. CIRCUIT AMPACITY 208/240V	OVER CURRENT PROTECTIVE DEVICE SIZE MIN./MAX
036ACT000NA	NONE	-	-	20/20	25/25	-	-	20/20	25/25
HEATER KW	A05C	3.8/5	10.4/12	23/25	25/25	13/15	15/15	20/20	25/25
	A08C	5.7/7.6	15.9/18.3	30/33	30/35	20/23	20/25	20/20	25/25
	A10C	7.2/9.6	20/23.1	35/39	35/40	25/29	25/30	20/20	25/25
	A15C	10.8/14.4	30.1/34.7	48/53	50/60	38/44	40/45	20/20	25/25
042ACT000NA	NONE	-	-	22/22	30/30	-	-	22/22	30/30
HEATER KW	A05C	3.8/5	10.4/12	22/23	30/30	13/15	15/15	22/22	30/30
	A08C	5.7/7.6	15.9/18.3	28/31	30/35	20/23	20/25	22/22	30/30
	A10C	7.2/9.6	20/23.1	33/37	35/40	25/29	25/30	22/22	30/30
	A15C	10.8/14.4	30.1/34.7	46/51	50/60	38/44	40/45	22/22	30/30
048ACT000NA	NONE	-	-	26/26	35/35	-	-	26/26	35/35
HEATER KW	A05C	3.8/5	10.4/12	26/26	35/35	13/15	15/15	26/26	35/35
	A08C	5.7/7.6	15.9/18.3	30/33	35/35	20/23	20/25	26/26	35/35
	A10C	7.2/9.6	20/23.1	35/39	35/40	25/29	25/30	26/26	35/35
	A15C	10.8/14.4	30.1/34.7	48/53	50/60	38/44	40/45	26/26	35/35
060ACT000NA	NONE	-	-	29/29	40/40	-	-	29/29	40/40
HEATER KW	A05C	3.8/5	10.4/12	29/29	40/40	13/15	15/15	29/29	40/40
	A08C	5.7/7.6	15.9/18.3	31/34	40/40	20/23	20/25	29/29	40/40
	A10C	7.2/9.6	20/23.1	37/40	40/40	25/29	25/30	29/29	40/40
	A15C	10.8/14.4	30.1/34.7	49/55	50/60	38/44	40/45	29/29	40/40

AUXILIARY ELECTRIC HEATER KITS CHARACTERISTICS AND APPLICATION: RACA-

480 VOLT, THREE PHASE, 60 HZ, AUXILIARY ELECTRIC HEATER KITS CHARACTERISTICS AND APPLICATION									
SINGLE POWER SUPPLY FOR BOTH UNIT AND HEATER KIT						SEPARATE POWER SUPPLY FOR BOTH UNIT AND HEATER KIT			
RHEEM MODEL NUMBER RACAZR	HEATER KIT			AIR CONDITIONER		HEATER KIT		AIR CONDITIONER	
	RXQJ- HEATER KIT NOMINAL KW	RATED HEATER KW @ 480 V	HEATER AMP. @ 480 V	UNIT MIN. CKT. AMPACITY @ 480 V	OVER CURRENT PROTECTIVE DEVICE SIZE MIN./MAX	MIN. CKT. AMPACITY 480V	MAX. FUSE SIZE 480V	MIN. CIRCUIT AMPACITY 480V	OVER CURRENT PROTECTIVE DEVICE SIZE MIN./MAX
036ADT000NA	NONE	-	-	10	15	-	-	10	15
HEATER KW	A05D	4.8	5.8	13	15	8	15	10	15
	A08D	7.6	9.1	17	20	12	15	10	15
	A10D	9.6	11.6	20	20	15	15	10	15
	A15D	14.4	17.3	27	30	22	25	10	15
048ADT000NA	NONE	-	-	13	15	-	-	13	15
HEATER KW	A05D	4.8	5.8	13	15	8	15	13	15
	A08D	7.6	9.1	17	20	12	15	13	15
	A10D	9.6	11.6	20	20	15	15	13	15
	A15D	14.4	17.3	27	30	22	25	13	15
060ADT000NA	NONE	-	-	14	15	-	-	14	15
HEATER KW	A05D	4.8	5.8	14	15	8	15	14	15
	A08D	7.6	9.1	17	20	12	15	14	15
	A10D	9.6	11.6	20	20	15	15	14	15
	A15D	14.4	17.3	27	30	22	25	14	15

AUXILIARY ELECTRIC HEATER KITS CHARACTERISTICS AND APPLICATION: RACA-

208/240 VOLT, SINGLE PHASE, 60 HZ, AUXILIARY ELECTRIC HEATER KITS CHARACTERISTICS AND APPLICATION									
SINGLE POWER SUPPLY FOR BOTH UNIT AND HEATER KIT						SEPARATE POWER SUPPLY FOR BOTH UNIT AND HEATER KIT			
RHEEM MODEL NUMBER RACAZR	HEATER KIT			AIR CONDITIONER		HEATER KIT		AIR CONDITIONER	
	RXQJ- HEATER KIT NOMINAL KW	RATED HEATER KW @ 208/240 V	HEATER AMP. @ 208/240 V	UNIT MIN. CKT. AMPACITY @ 208/240 V	OVER CURRENT PROTECTIVE DEVICE SIZE MIN./MAX	MIN. CKT. AMPACITY 208/240V	MAX. FUSE SIZE 208/240V	MIN. CIRCUIT AMPACITY 208/240V	OVER CURRENT PROTECTIVE DEVICE SIZE MIN./MAX
024AJT000NA	NONE	-	-	18/18	25/25	-	-	18/18	25/25
HEATER KW	A05J	3.6/4.8	17.3/20	26/29	30/30	22/25	25/25	18/18	25/25
	A08J	5.7/7.6	27.4/31.6	38/43	40/45	35/40	35/40	18/18	25/25
	A10J	7.2/9.6	34.6/40	47/54	50/60	44/50	45/50	18/18	25/25
030AJT000NA	NONE	-	-	21/21	30/30	-	-	21/21	30/30
HEATER KW	A05J	3.6/4.8	17.3/20	27/31	30/35	22/25	25/25	21/21	30/30
	A08J	5.7/7.6	27.4/31.6	40/45	40/45	35/40	35/40	21/21	30/30
	A10J	7.2/9.6	34.6/40	49/56	50/60	44/50	45/50	21/21	30/30
036AJT000NA	NONE	-	-	28/28	40/40	-	-	28/28	40/40
HEATER KW	A05J	3.6/4.8	17.3/20	32/35	40/40	22/25	25/25	28/28	40/40
	A08J	5.7/7.6	27.4/31.6	44/49	45/50	35/40	35/40	28/28	40/40
	A10J	7.2/9.6	34.6/40	53/60	60/60	44/50	45/50	28/28	40/40
	A15J	10.8/14.4	51.9/60	75/85	80/90	65/75	70/80	28/28	40/40
042AJT000NA	NONE	-	-	28/28	40/40	-	-	28/28	40/40
HEATER KW	A05J	3.6/4.8	17.3/20	30/33	40/40	22/25	25/25	28/28	40/40
	A08J	5.7/7.6	27.4/31.6	42/47	45/50	35/40	35/40	28/28	40/40
	B10J	7.2/9.6	34.6/40	51/58	60/60	44/50	45/50	28/28	40/40
	B15J	10.8/14.4	51.9/60	73/83	80/90	65/75	70/80	28/28	40/40
048AJT000NA	NONE	-	-	36/36	50/50	-	-	36/36	50/50
HEATER KW	A05J	3.6/4.8	17.3/20	36/37	50/50	22/25	25/25	36/36	50/50
	A08J	5.7/7.6	27.4/31.6	46/51	50/60	35/40	35/40	36/36	50/50
	B10J	7.2/9.6	34.6/40	55/62	60/70	44/50	45/50	36/36	50/50
	B15J	10.8/14.4	51.9/60	76/87	80/90	65/75	70/80	36/36	50/50
060AJT000NA	NONE	-	-	41/41	60/60	-	-	41/41	60/60
HEATER KW	A05J	3.6/4.8	17.3/20	41/41	60/60	22/25	25/25	41/41	60/60
	A08J	5.7/7.6	27.4/31.6	46/51	60/60	35/40	35/40	41/41	60/60
	B10J	7.2/9.6	34.6/40	55/62	60/70	44/50	45/50	41/41	60/60
	B15J	10.8/14.4	51.9/60	76/87	80/90	65/75	70/80	41/41	60/60

XXIII. WIRING DIAGRAMS

FIGURE 11
WIRING DIAGRAM

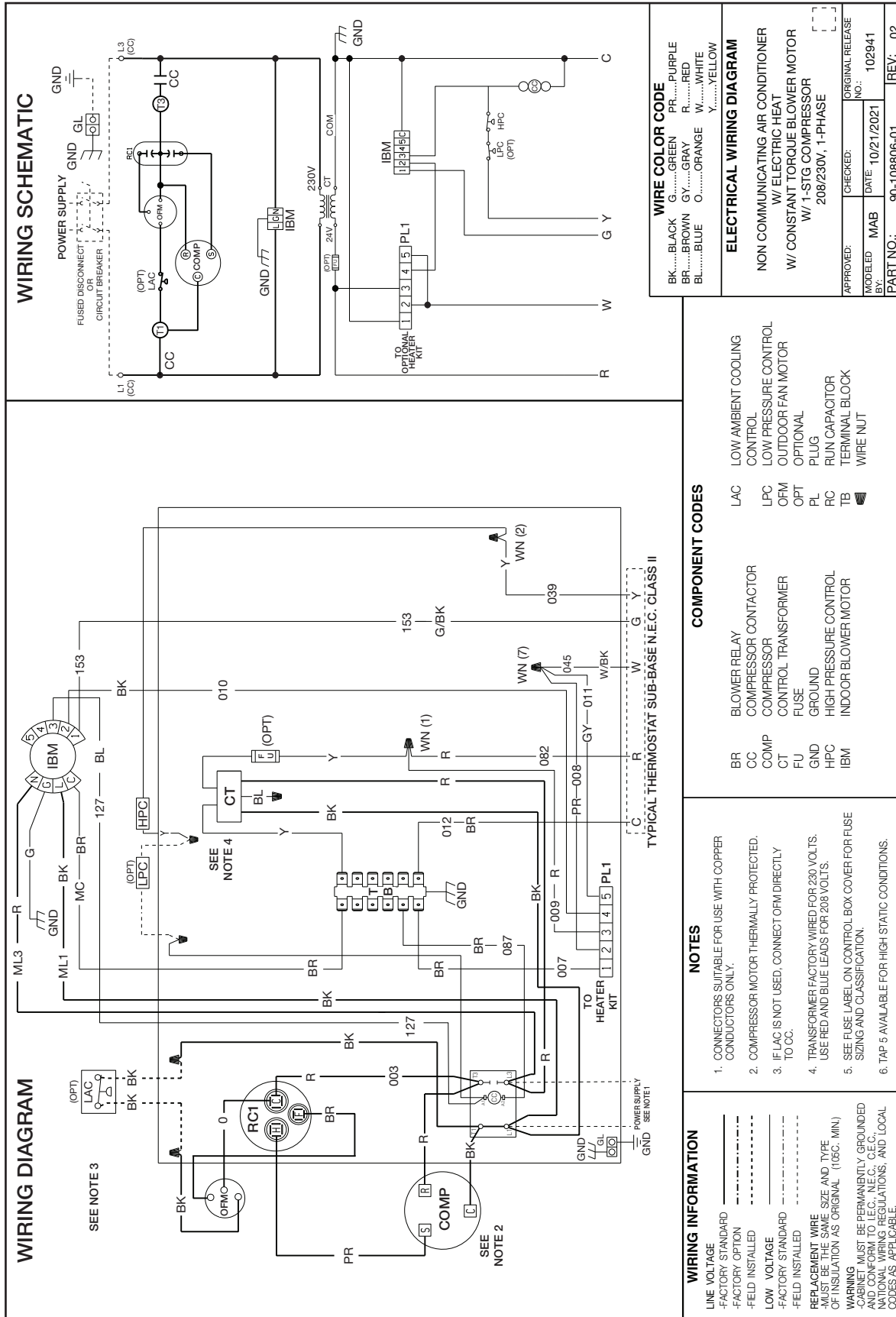
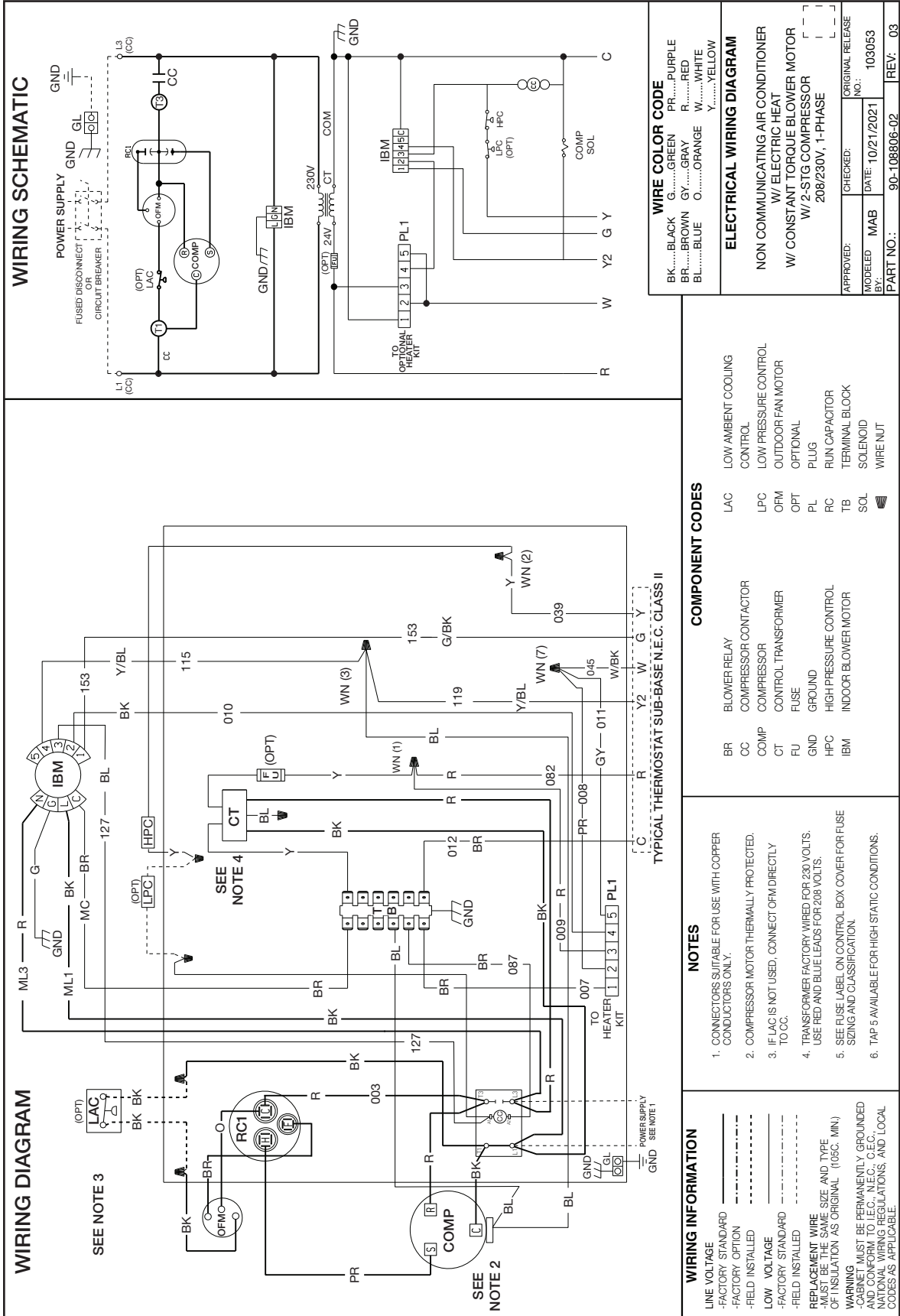

FIGURE 12
WIRING DIAGRAM



WIRE COLOR CODE

BK.....BLACK G.....GREEN PR.....PURPLE
 BR.....BROWN GY.....GRAY R.....RED
 BL.....BLUE O.....ORANGE W.....WHITE
 Y.....YELLOW

ELECTRICAL WIRING DIAGRAM

NON COMMUNICATING AIR CONDITIONER
 W/ ELECTRIC HEAT
 W/ CONSTANT TORQUE BLOWER MOTOR
 W/ 2-STG COMPRESSOR
 208/230V, 1-PHASE

APPROVED: _____ CHECKED: _____ ORIGINAL RELEASE NO.: _____
 MODEL# MAB DATE: 10/21/2021 NO.: 103053
 PART NO.: 90-108806-02 REV: 03

COMPONENT CODES

BR BLOWER RELAY
 CC COMPRESSOR CONTACTOR
 COMP COMPRESSOR
 CT CONTROL TRANSFORMER
 FU FUSE
 GND GROUND
 HPC HIGH PRESSURE CONTROL
 IBM INDOOR BLOWER MOTOR

LAC LOW AMBIENT COOLING CONTROL
 LPC LOW PRESSURE CONTROL
 OFM OUTDOOR FAN MOTOR
 OPT OPTIONAL
 PL PLUG
 RC RUN CAPACITOR
 TB TERMINAL BLOCK
 SOL SOLENOID
 W/NUT WIRE NUT

NOTES

- CONNECTORS SUITABLE FOR USE WITH COPPER CONDUCTORS ONLY.
- COMPRESSOR MOTOR THERMALLY PROTECTED.
- IF LAC IS NOT USED, CONNECT OFM DIRECTLY TO CC.
- TRANSFORMER FACTORY WIRED FOR 230 VOLTS. USE RED AND BLUE LEADS FOR 208 VOLTS.
- SEE FUSE LABEL ON CONTROL BOX COVER FOR FUSE SIZING AND CLASSIFICATION.
- TAP 5 AVAILABLE FOR HIGH STATIC CONDITIONS.

WIRING INFORMATION

LINE VOLTAGE
 -FACTORY STANDARD
 -FACTORY OPTION
 -FIELD INSTALLED

LOW VOLTAGE
 -FACTORY STANDARD
 -FIELD INSTALLED

REPLACEMENT WIRE
 -MUST BE THE SAME SIZE AND TYPE OF INSULATION AS ORIGINAL (105C, MIN.)

WARNING
 -CABINET MUST BE PERMANENTLY GROUNDED AND CONFORM TO I.E.C., N.E.C., C.E.C., NATIONAL WIRING REGULATIONS, AND LOCAL CODES AS APPLICABLE.

FIGURE 13
WIRING DIAGRAM

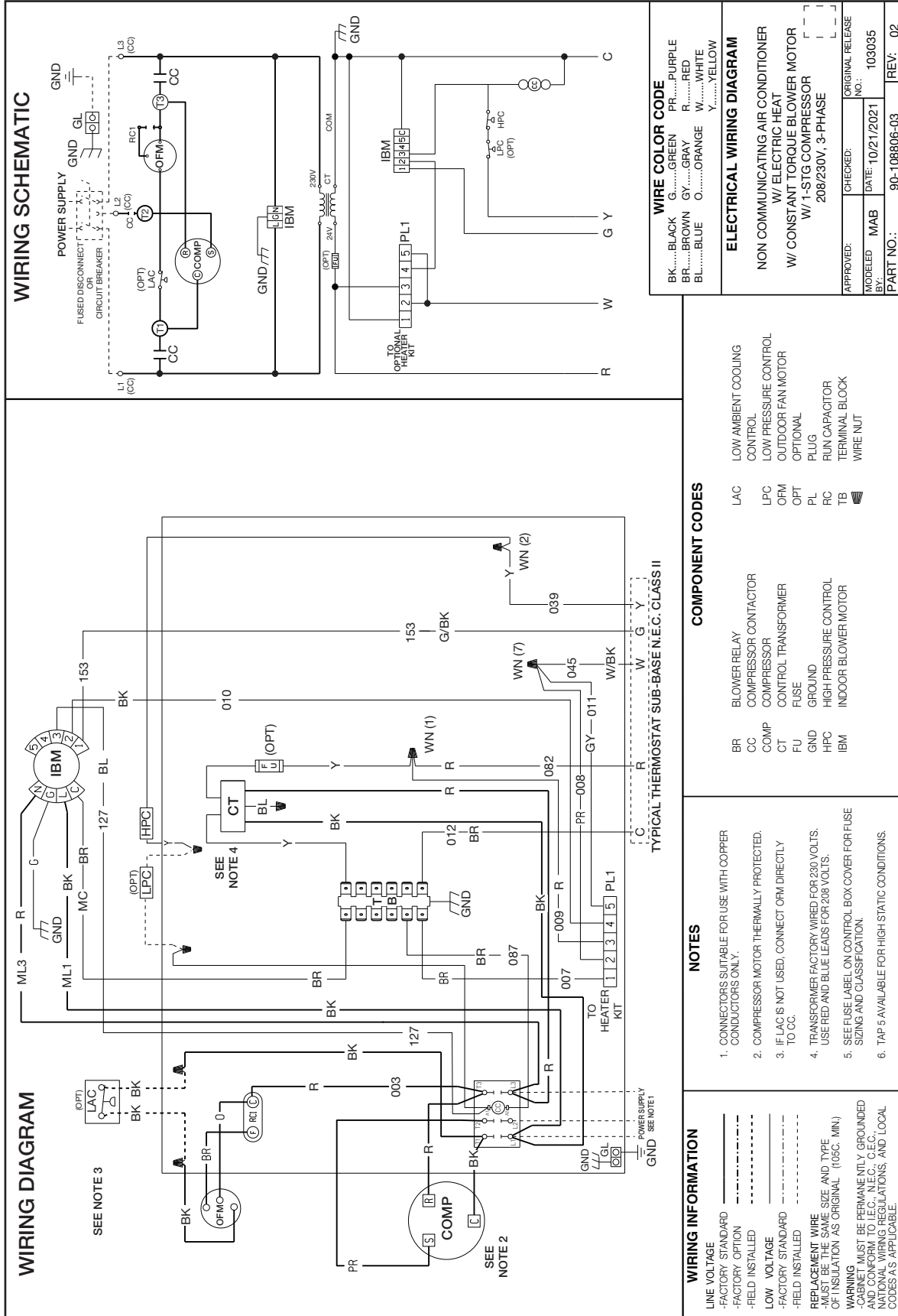

WIRING SCHEMATIC

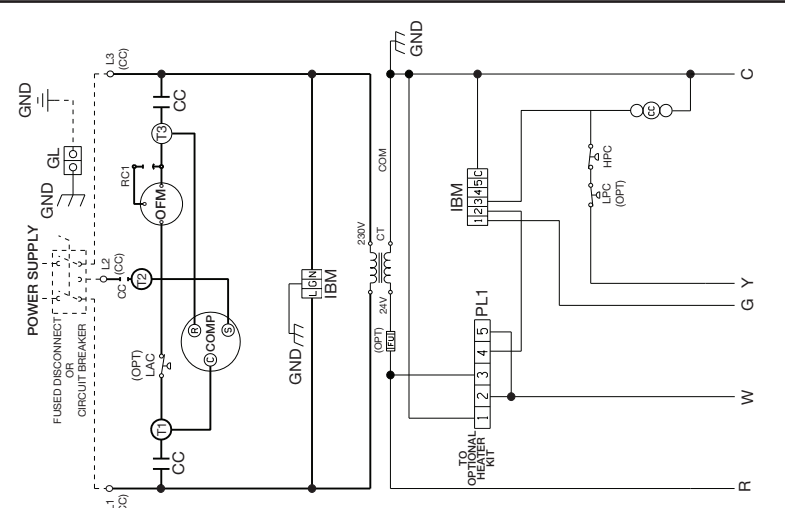

WIRE COLOR CODE

BK.....BLACK	G.....GREEN	PR.....PURPLE
BR.....BROWN	GY.....GRAY	R.....RED
BL.....BLUE	O.....ORANGE	W.....WHITE
	Y.....YELLOW	

ELECTRICAL WIRING DIAGRAM

NON COMMUNICATING AIR CONDITIONER
W/ ELECTRIC HEAT
W/ CONSTANT TORQUE BLOWER MOTOR
W/1-STG COMPRESSOR
208/230V, 3-PHASE

APPROVED:	CHECKED:	ORIGINAL RELEASE
MODELED BY: MAB	DATE: 10/21/2021	NO.:
PART NO.:	90-108806-03	REV: 02

WIRING DIAGRAM

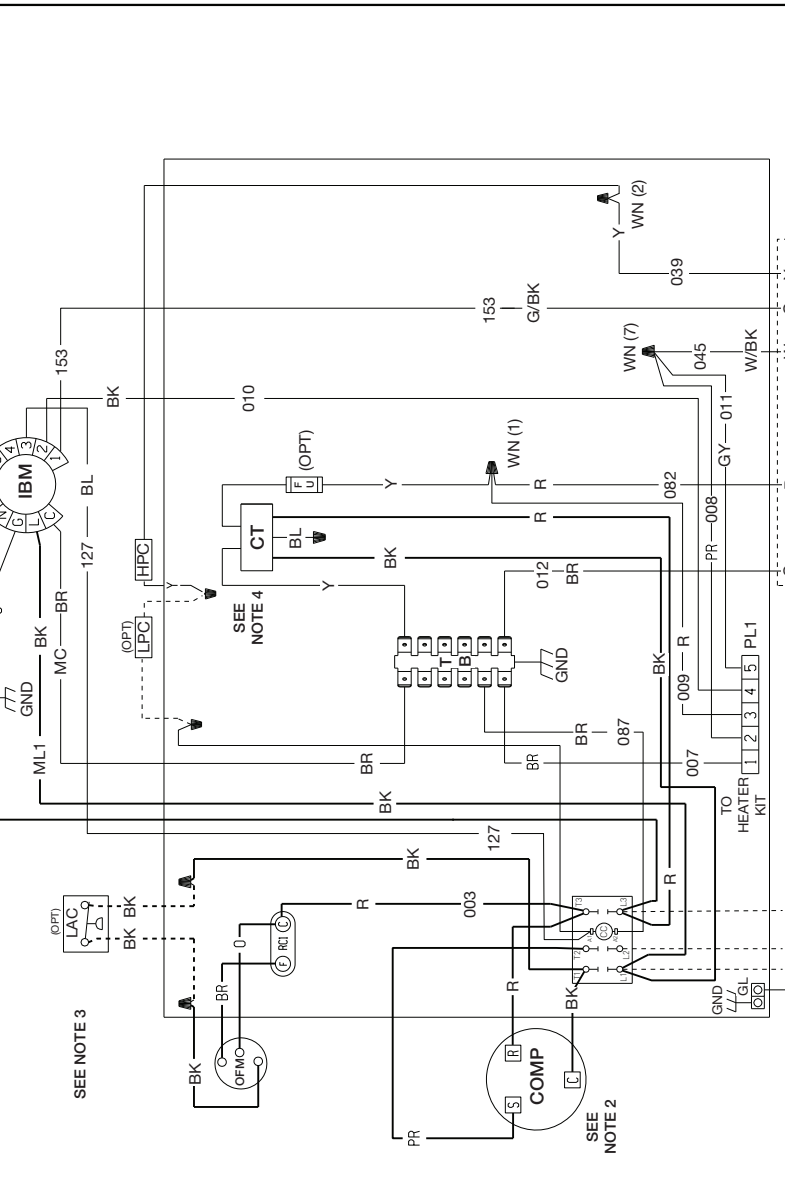

COMPONENT CODES

BR	BLOWER RELAY	LAC	LOW AMBIENT COOLING CONTROL
CC	COMPRESSOR CONTACTOR	LPC	LOW PRESSURE CONTROL
COMP	COMPRESSOR	OFM	OUTDOOR FAN MOTOR
CT	CONTROL TRANSFORMER	OPT	OPTIONAL
FU	FUSE	PL	PLUG
GND	GROUND	RC	RUN CAPACITOR
HPC	HIGH PRESSURE CONTROL	TB	TERMINAL BLOCK
IBM	INDOOR BLOWER MOTOR	WN	WIRE NUT

- NOTES**
- CONNECTORS SUITABLE FOR USE WITH COPPER CONDUCTORS ONLY.
 - COMPRESSOR MOTOR THERMALLY PROTECTED.
 - IF LAC IS NOT USED, CONNECT ORN DIRECTLY TO CC.
 - TRANSFORMER FACTORY WIRED FOR 230 VOLTS. USE RED AND BLUE LEADS FOR 208 VOLTS.
 - SEE FUSE LABEL ON CONTROL BOX COVER FOR FUSE SIZING AND CLASSIFICATION.
 - TAP 5 AVAILABLE FOR HIGH STATIC CONDITIONS.

- WIRING INFORMATION**
- LINE VOLTAGE
 - FACTORY STANDARD
 - FACTORY OPTION
 - FIELD INSTALLED
 - LOW VOLTAGE
 - FACTORY STANDARD
 - FIELD INSTALLED
 - REPLACEMENT WIRE
 - MUST BE THE SAME SIZE AND TYPE
 - OF INSULATION AS ORIGINAL (105C, MIN.)
 - WARNING
 - CABINET MUST BE PERMANENTLY GROUNDED AND CONFORM TO I.E.C., N.E.C., C.E.C., NATIONAL WIRING REGULATIONS, AND LOCAL CODES AS APPLICABLE.

FIGURE 14
WIRING DIAGRAM

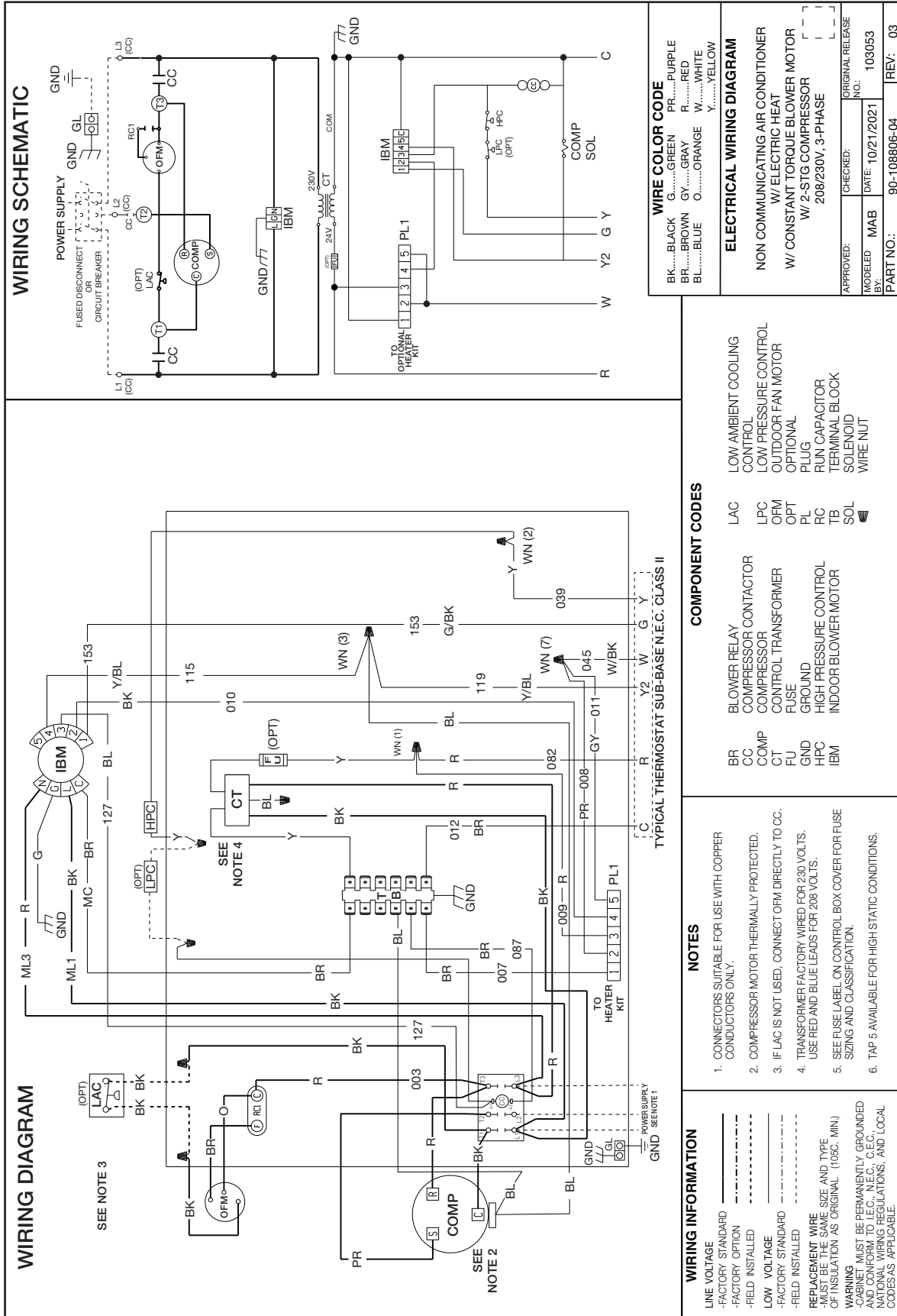

WIRING SCHEMATIC

WIRING DIAGRAM

WIRE COLOR CODE

BK.....BLACK G.....GREEN PR.....PURPLE
 BR.....BROWN GY.....GRAY R.....RED
 BL.....BLUE O.....ORANGE W.....WHITE
 Y.....YELLOW

ELECTRICAL WIRING DIAGRAM

NON COMMUNICATING AIR CONDITIONER
 W/ ELECTRIC HEAT
 W/ CONSTANT TORQUE BLOWER MOTOR
 W/ 2-STG COMPRESSOR
 208/230V, 3-PHASE

APPROVED:	CHECKED:	ORIGINAL RELEASE NO.:
MODELED MAB	DATE: 10/21/2021	103063
BY:		
PART NO.:	90-108806-04	REV: 03

COMPONENT CODES

BR BLOWER RELAY
 CC COMPRESSOR CONTACTOR
 COMP COMPRESSOR
 CT CONTROL TRANSFORMER
 FU FUSE
 GND GROUND
 HPC HIGH PRESSURE CONTROL
 IBM INDOOR BLOWER MOTOR
 LAC LOW AMBIENT COOLING CONTROL
 LPC LOW PRESSURE CONTROL
 OFM OUTDOOR FAN MOTOR
 OPT OPTIONAL
 PL PLUG
 RC RUN CAPACITOR
 TB TERMINAL BLOCK
 SOL SOLENOID
 WIRE NUT

NOTES

- CONNECTORS SUITABLE FOR USE WITH COPPER CONDUCTORS ONLY.
- COMPRESSOR MOTOR THERMALLY PROTECTED.
- IF LAC IS NOT USED, CONNECT OFM DIRECTLY TO CC.
- TRANSFORMER FACTORY WIRED FOR 230 VOLTS. USE RED AND BLUE LEADS FOR 208 VOLTS.
- SEE FUSE LABEL ON CONTROL BOX COVER FOR FUSE SIZING AND CLASSIFICATION.
- TAP 5 AVAILABLE FOR HIGH STATIC CONDITIONS.

WIRING INFORMATION

LINE VOLTAGE
 -FACTORY STANDARD
 -FIELD INSTALLED
 LOW VOLTAGE
 -FACTORY STANDARD
 -FIELD INSTALLED
 REPLACEMENT WIRE
 -MUST BE THE SAME SIZE AND TYPE
 OF INSULATION AS ORIGINAL (105C, MIN.)
 WARNING
 -CABINET MUST BE PERMANENTLY GROUNDED
 -CONFORM TO I.E.C., N.E.C., C.E.C.,
 AND ALL APPLICABLE REGULATIONS, AND LOCAL
 CODES AS APPLICABLE.

FIGURE 15
WIRING DIAGRAM

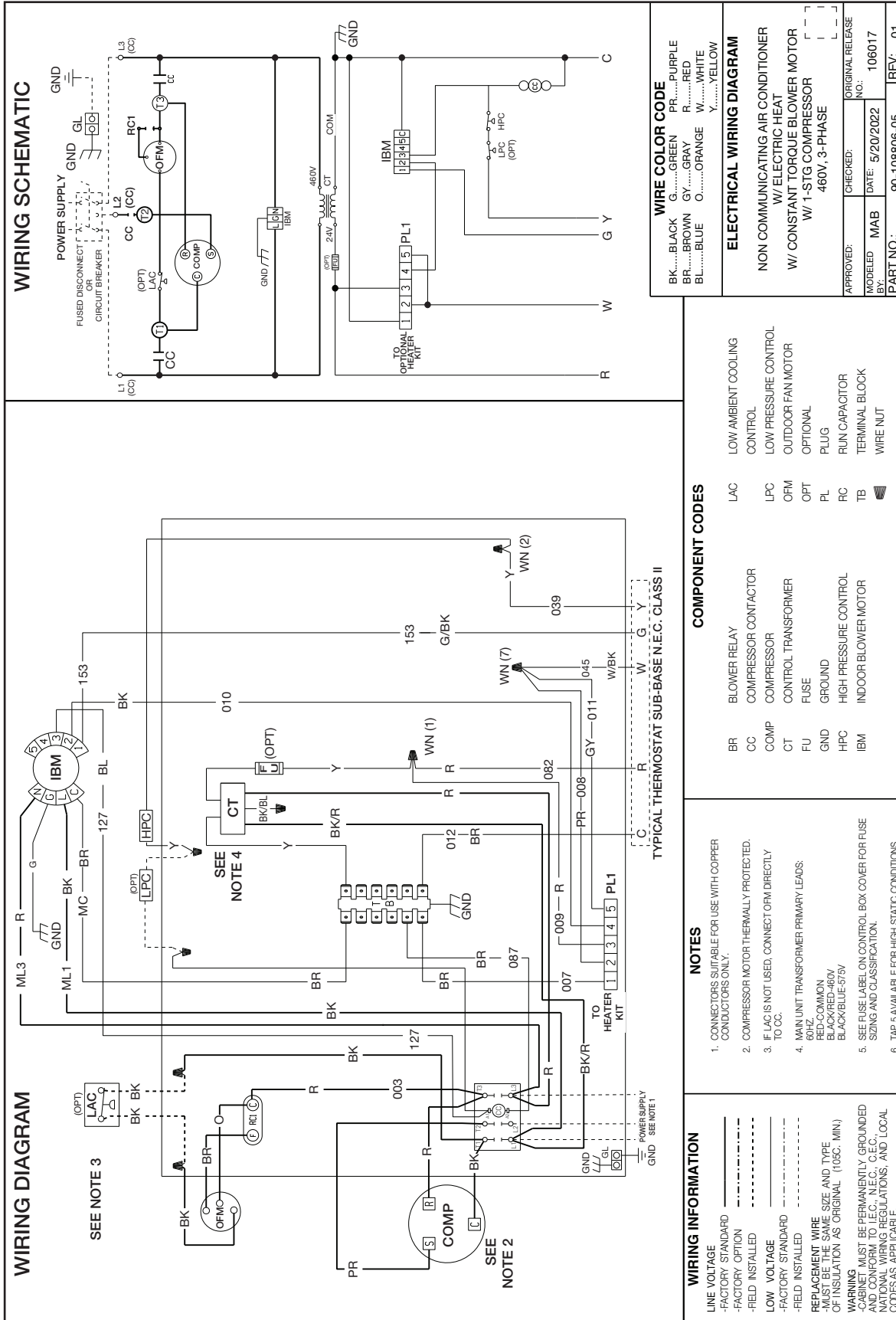
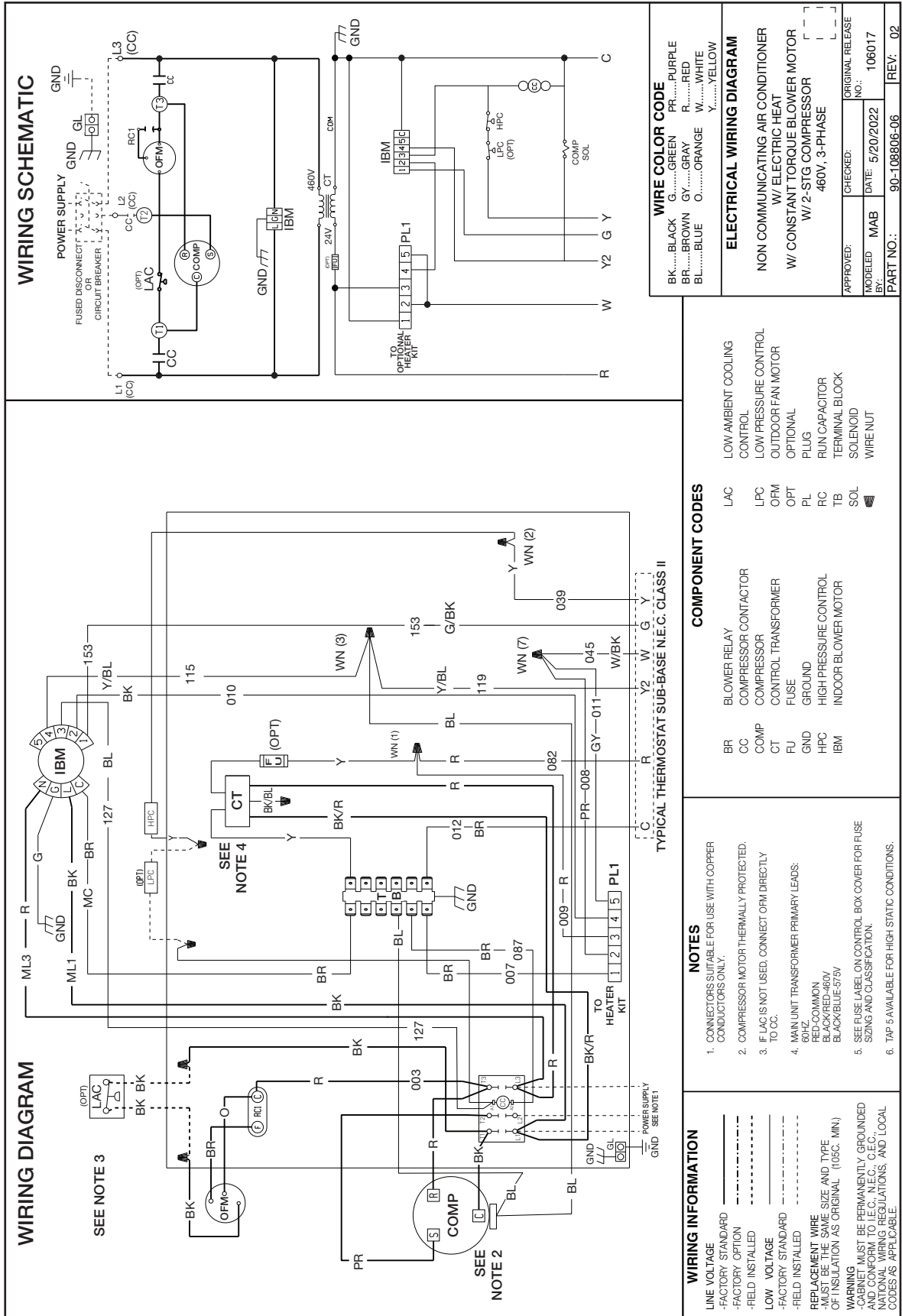
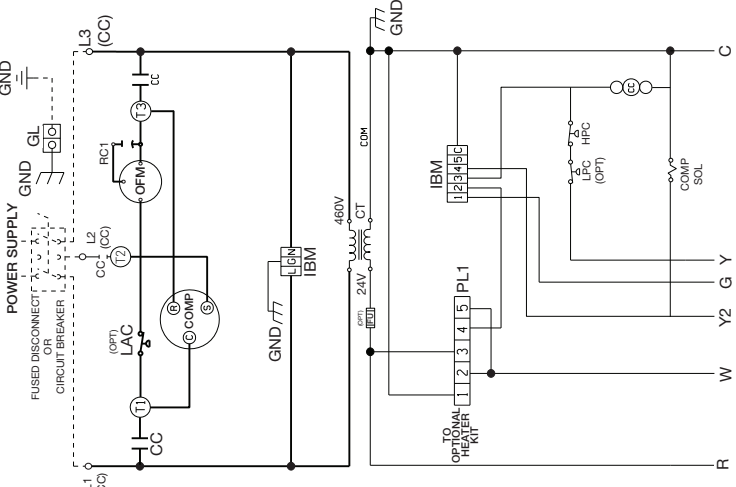

FIGURE 16
WIRING DIAGRAM



WIRING SCHEMATIC



WIRE COLOR CODE

BK.....BLACK	G.....GREEN	PR.....PURPLE
BR.....BROWN	GY.....GRAY	R.....RED
BL.....BLUE	O.....ORANGE	W.....WHITE
		Y.....YELLOW

ELECTRICAL WIRING DIAGRAM

NON COMMUNICATING AIR CONDITIONER
W/ ELECTRIC HEAT
W/ CONSTANT TORQUE BLOWER MOTOR
W/ 2-STG COMPRESSOR
460V, 3-PHASE

APPROVED:	CHECKED:	ORIGINAL RELEASE NO.:
MODELED BY: MAB	DATE: 5/20/2022	NO. 106017
PART NO.:	90-108806-06	REV: 02

WIRING DIAGRAM

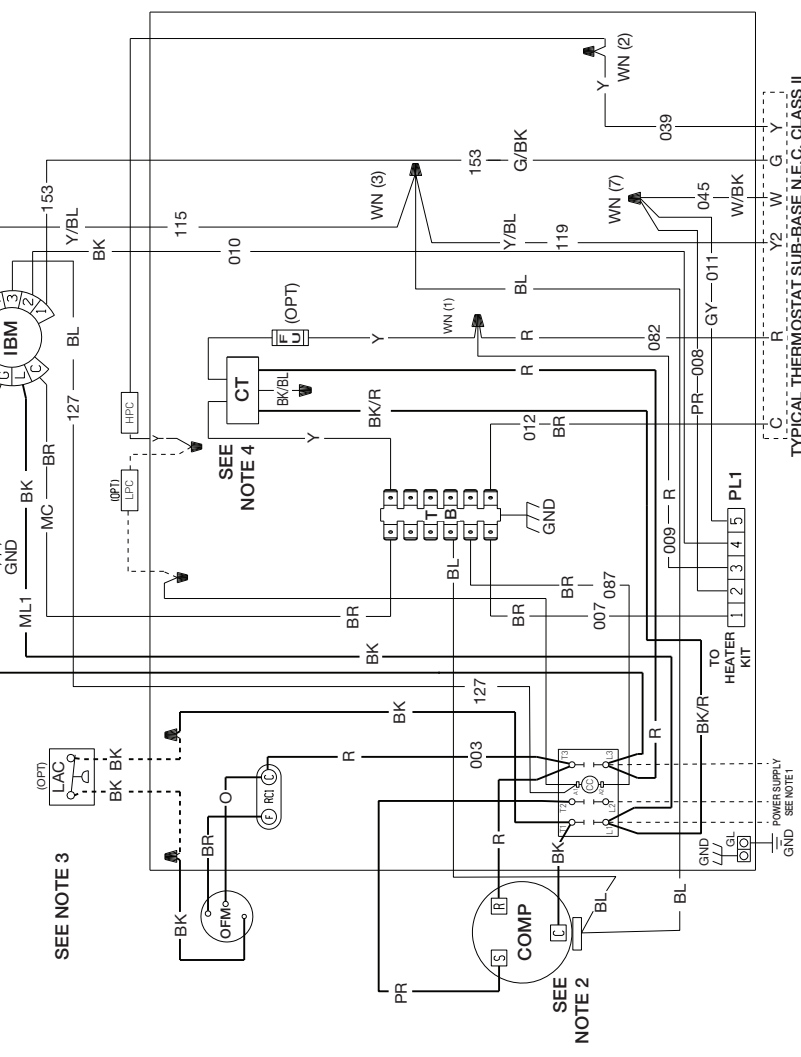

COMPONENT CODES

BR	BLOWER RELAY
CC	COMPRESSOR CONTACTOR
COMP	COMPRESSOR
CT	CONTROL TRANSFORMER
FU	FUSE
GND	GROUND
HPC	HIGH PRESSURE CONTROL
IBM	INDOOR BLOWER MOTOR
LAC	LOW AMBIENT COOLING CONTROL
LPC	LOW PRESSURE CONTROL
OFM	OUTDOOR FAN MOTOR
OPT	OPTIONAL
PL	PLUG
RC	RUN CAPACITOR
TB	TERMINAL BLOCK
SOL	SOLENOID
WN	WIRE NUT

- NOTES**
- CONNECTORS SUITABLE FOR USE WITH COPPER CONDUCTORS ONLY.
 - COMPRESSOR MOTOR THERMALLY PROTECTED.
 - IF LAC IS NOT USED, CONNECT ORV DIRECTLY TO CC.
 - MAIN UNIT TRANSFORMER PRIMARY LEADS: 60HZ RED-COMMON BLACK-RED-460V BLACK-BLUE-95V
 - SEE FUSE LABEL ON CONTROL BOX COVER FOR FUSE SIZING AND CLASSIFICATION.
 - TAP 5 AVAILABLE FOR HIGH STATIC CONDITIONS.

- WIRING INFORMATION**
- LINE VOLTAGE
 - FACTORY STANDARD
 - FACTORY OPTION
 - FIELD INSTALLED
 - LOW VOLTAGE
 - FACTORY STANDARD
 - FIELD INSTALLED
 - REPLACEMENT WIRE SIZE AND TYPE
 - FACTORY STANDARD
 - FIELD INSTALLED
 - INSULATION AS ORIGINAL (105C, MN)
 - WARNING: WIRING MUST BE PERMANENTLY GROUNDED AND CONFORM TO I.E.C. (N.E.C., C.E.C.) NATIONAL WIRING REGULATIONS, AND LOCAL CODES AS APPLICABLE.

XXIV. TROUBLESHOOTING CHART

FIGURE 17

▲ WARNING

DISCONNECT ALL POWER TO UNIT BEFORE SERVICING. CONTACTOR MAY BREAK ONLY ONE SIDE. FAILURE TO SHUT OFF POWER CAN CAUSE ELECTRICAL SHOCK RESULTING IN PERSONAL INJURY OR DEATH.

SYMPTOM	POSSIBLE CAUSE	REMEDY
Unit will not run	<ul style="list-style-type: none"> Power off or loose electrical connection Thermostat out of calibration-set too high Defective contactor Blown fuses Transformer defective High pressure control open (if provided) Interconnecting low voltage wiring damaged 	<ul style="list-style-type: none"> Check for correct voltage at compressor contactor in control box Reset Check for 24 volts at contactor coil - replace if contacts are open Replace fuses Check wiring-replace transformer Reset-also see high head pressure remedy-The high pressure control opens at 610 PSIG Replace thermostat wiring
Condenser fan runs, compressor doesn't	<ul style="list-style-type: none"> Run or start capacitor defective (single phase only) Start relay defective (single phase only) Loose connection Compressor stuck, grounded or open motor winding. open internal overload. Low voltage condition Low voltage condition 	<ul style="list-style-type: none"> Replace Replace Check for correct voltage at compressor - check & tighten all connections Wait at least 2 hours for overload to reset. If still open, replace the compressor. At compressor terminals, voltage must be within 10% of rating plate volts when unit is operating. Add start kit components.
Insufficient cooling	<ul style="list-style-type: none"> Improperly sized unit Improper airflow Incorrect refrigerant charge Air, non-condensibles or moisture in system Incorrect voltage 	<ul style="list-style-type: none"> Recalculate load Check - should be approximately 400 CFM per ton. Charge per procedure attached to unit service panel Recover refrigerant, evacuate & recharge, add filter drier At compressor terminals, voltage must be within 10% of rating plate volts when unit is operating.
Compressor short cycles	<ul style="list-style-type: none"> Incorrect voltage Defective overload protector Refrigerant undercharge 	<ul style="list-style-type: none"> At compressor terminals, voltage must be $\pm 10\%$ of nameplate marking when unit is operating. Replace - check for correct voltage Add refrigerant
Registers sweat	<ul style="list-style-type: none"> Low evaporator airflow 	<ul style="list-style-type: none"> Increase speed of blower or reduce restriction - replace air filter
High head-low vapor pressures	<ul style="list-style-type: none"> Restriction in liquid line, expansion device or filter drier Flow check piston size too small Incorrect capillary tubes TXV does not open 	<ul style="list-style-type: none"> Remove or replace defective component Change to correct size piston Change coil assembly Replace TXV
High head-high or normal vapor pressure - Cooling mode	<ul style="list-style-type: none"> Dirty condenser coil Refrigerant overcharge Condenser fan not running Air or non-condensibles in system 	<ul style="list-style-type: none"> Clean coil Correct system charge Repair or replace Recover refrigerant, evacuate & recharge
Low head-high vapor pressures	<ul style="list-style-type: none"> Flow check piston size too large Defective Compressor valves Incorrect capillary tubes 	<ul style="list-style-type: none"> Change to correct size piston Replace compressor Replace coil assembly
Low vapor - cool compressor - iced evaporator coil	<ul style="list-style-type: none"> Low evaporator airflow Operating below 65°F outdoors Moisture in system TXV limiting refrigerant flow 	<ul style="list-style-type: none"> Increase speed of blower or reduce restriction - replace air filter Add Low Ambient Kit Recover refrigerant - evacuate & recharge - add filter drier Replace TXV
High vapor pressure	<ul style="list-style-type: none"> Excessive load Defective compressor 	<ul style="list-style-type: none"> Recheck load calculation Replace
Fluctuating head & vapor pressures	<ul style="list-style-type: none"> TXV hunting Air or non-condensibles in system 	<ul style="list-style-type: none"> Check TXV bulb clamp - check air distribution on coil - replace TXV Recover refrigerant, evacuate & recharge
Gurgle or pulsing noise at expansion device or liquid line	<ul style="list-style-type: none"> Air or non-condensibles in system 	<ul style="list-style-type: none"> Recover refrigerant, evacuate & recharge

