

# INSTALLATION INSTRUCTIONS

## PACKAGE HEAT PUMPS

### RQNJ SERIES — (2.0 - 5.0 TONS)



RECOGNIZE THIS SYMBOL AS AN INDICATION OF IMPORTANT SAFETY INFORMATION!

#### **▲ WARNING**

THESE INSTRUCTIONS ARE INTENDED AS AN AID TO QUALIFIED, LICENSED SERVICE PERSONNEL FOR PROPER INSTALLATION, ADJUSTMENT AND OPERATION OF THIS UNIT. READ THESE INSTRUCTIONS THOROUGHLY BEFORE ATTEMPTING INSTALLATION OR OPERATION. FAILURE TO FOLLOW THESE INSTRUCTIONS MAY RESULT IN IMPROPER INSTALLATION, ADJUSTMENT, SERVICE OR MAINTENANCE POSSIBLY RESULTING IN FIRE, ELECTRICAL SHOCK, PROPERTY DAMAGE, PERSONAL INJURY OR DEATH.



**ISO 9001:2000**

Certificate Number: 30164

**DO NOT DESTROY THIS MANUAL**

**PLEASE READ CAREFULLY AND KEEP IN A SAFE PLACE FOR FUTURE REFERENCE BY A SERVICEMAN**

# I. TABLE OF CONTENTS

I. Table of Contents .....	2
II. Introduction.....	3
III. Checking Product Received .....	3
IV. Equipment Protection .....	3
V. Specifications .....	6
VI. Installation .....	6
A. General .....	6
1. Pre-Installation Check Points .....	6
2. Location.....	6
B. Outside Slab Installation .....	6
C. Clearances .....	6
D. Rooftop Installation .....	6
VII. Ductwork.....	7
VIII. Filters.....	8
IX. Condensate Drain, Indoor Coil .....	8
X. Condensate Drain, Outdoor Coil .....	8
XI. Electrical Wiring.....	8
A. Power Wiring.....	8
B. Electric Heater Kit Instructions .....	9
C. Control Wiring .....	9
D. Internal Wiring .....	10
E. Grounding .....	10
F. Thermostat .....	10
XII. Indoor Air Flow Data.....	10
XIII. Pre-Start Check .....	10
XIV. Startup .....	11
XV. Operation.....	12
XVI. Auxiliary Heat .....	12
XVII. Demand Defrost Control.....	12
XVIII. General Data .....	14-16
XIX. Miscellaneous	
Electrical and Physical Data.....	17-18
Airflow Performance .....	19-20
Wiring Diagram.....	23-28
Charge Charts .....	29-34
Troubleshooting.....	35

► Installation instructions are updated on a regular basis. This is done as product changes occur or if new information becomes available. In this publication, an arrow ( ► ) denotes changes from the previous edition or additional new material.

## WARNING

**PROPOSITION 65: THIS APPLIANCE CONTAINS FIBERGLASS INSULATION. RESPIRABLE PARTICLES OF FIBERGLASS ARE KNOWN TO THE STATE OF CALIFORNIA TO CAUSE CANCER.**

## WARNING

**THE MANUFACTURER'S WARRANTY DOES NOT COVER ANY DAMAGE OR DEFECT TO THE HEAT PUMP CAUSED BY THE ATTACHMENT OR USE OF ANY COMPONENTS, ACCESSORIES OR DEVICES (OTHER THAN THOSE AUTHORIZED BY THE MANUFACTURER) INTO, ONTO OR IN CONJUNCTION WITH THE HEAT PUMP. YOU SHOULD BE AWARE THAT THE USE OF UNAUTHORIZED COMPONENTS, ACCESSORIES OR DEVICES MAY ADVERSELY AFFECT THE OPERATION OF THE HEAT PUMP AND MAY ALSO ENDANGER LIFE AND PROPERTY. THE MANUFACTURER DISCLAIMS ANY RESPONSIBILITY FOR SUCH LOSS OR INJURY RESULTING FROM THE USE OF SUCH UNAUTHORIZED COMPONENTS, ACCESSORIES OR DEVICES.**

## II. INTRODUCTION

This booklet contains the installation and operating instructions for your package heat pump. There are a few precautions that should be taken to derive maximum satisfaction from it. Improper installation can result in unsatisfactory operation or dangerous conditions.

Read this booklet and any instructions packaged with separate equipment required to make up the system prior to installation. Give this booklet to the owner and explain its provisions. The owner should retain this booklet for future reference.

## III. CHECKING PRODUCT RECEIVED

Upon receiving the unit, inspect it for any damage from shipment. Claims for damage, either shipping or concealed, should be filed immediately with the shipping company. Check the unit model number, heating size, electrical characteristics, and accessories to determine if they are correct.

## IV. EQUIPMENT PROTECTION FROM THE ENVIRONMENT

The metal parts of this unit may be subject to rust or deterioration in adverse environmental conditions. This oxidation could shorten the equipment's useful life. Salt spray, fog or mist in seacoast areas, sulphur or chlorine from lawn watering systems, and various chemical contaminants from industries such as paper mills and petroleum refineries are especially corrosive.

**If the unit is to be installed in an area where contaminants are likely to be a problem, special attention should be given to the equipment location and exposure.**

1. Avoid having lawn sprinkler heads spray direction on the unit cabinet.
2. In coastal areas, locate the unit on the side of the building away from the waterfront.
3. Shielding provided by a fence or shrubs may give some protection.
4. Elevating the unit off its slab or base enough to allow air circulation will help avoid holding water against the basepan.

**Regular maintenance will reduce the buildup of contaminants and help to protect the unit's finish.**

## WARNING

**DISCONNECT ALL POWER TO THE UNIT BEFORE STARTING MAINTENANCE. FAILURE TO DO SO CAN RESULT IN SEVERE ELECTRICAL SHOCK OR DEATH.**

1. Frequent washing of the cabinet, fan blade and coil with fresh water will remove most of the salt or other contaminants that build up on the unit.
2. Regular cleaning and waxing of the cabinet with an automobile polish will provide some protection.
3. A liquid cleaner may be used several times a year to remove matter that will not wash off with water.

Several different types of protective coatings are offered in some areas. These coatings may provide some benefit, but the effectiveness of such coating materials cannot be verified by the equipment manufacturer.

**The best protection is frequent cleaning, maintenance and minimal exposure to contaminants.**

**FIGURE 1**  
**UNIT DIMENSIONS AND ACCESS LOCATIONS**

Model	Height "A"
024, 030, 036	29 1/8"
042, 048, 060	37 1/8"

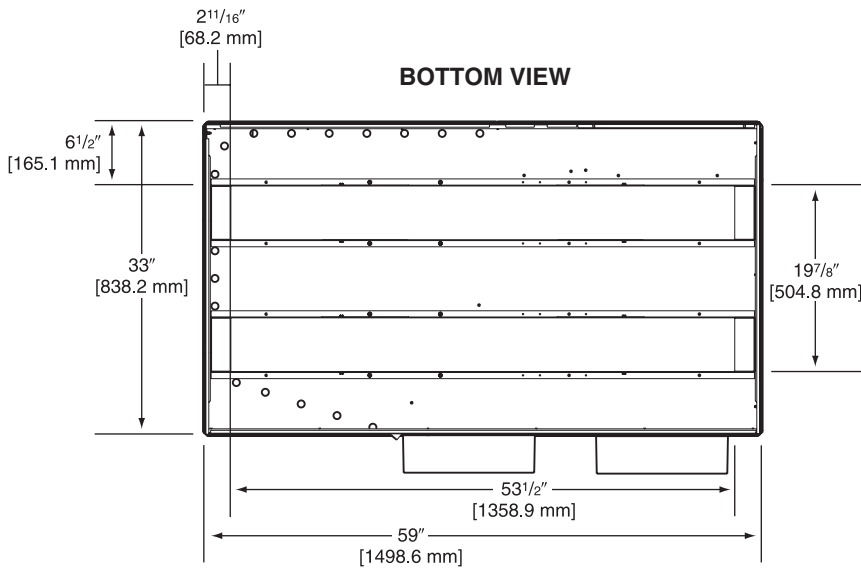
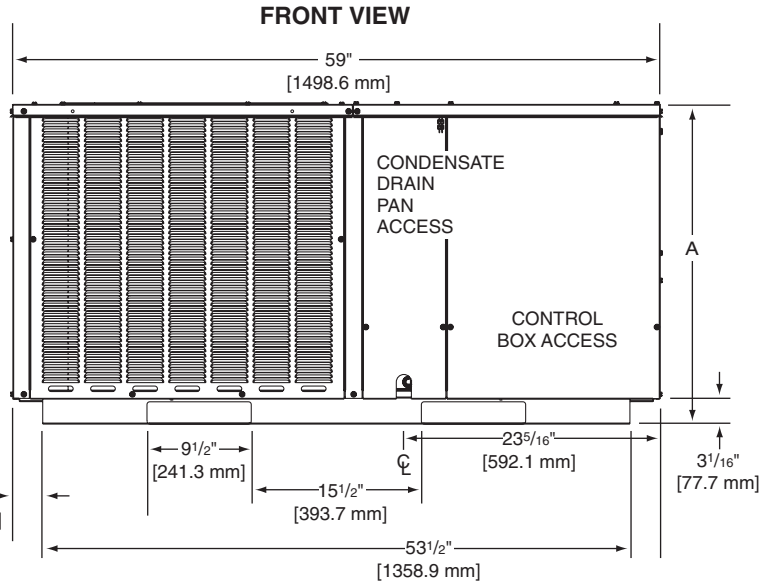

**ELECTRICAL CONNECTIONS**

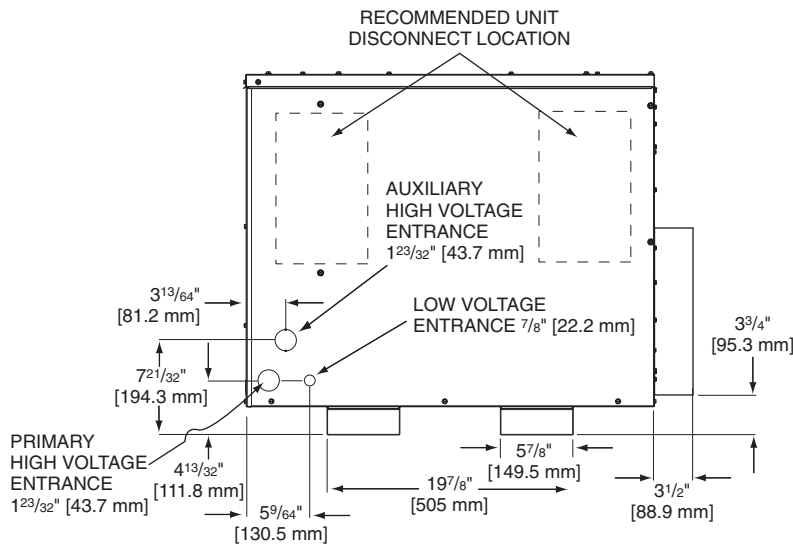

# DUCT CONNECTIONS

## ROUND DUCT CONNECTIONS

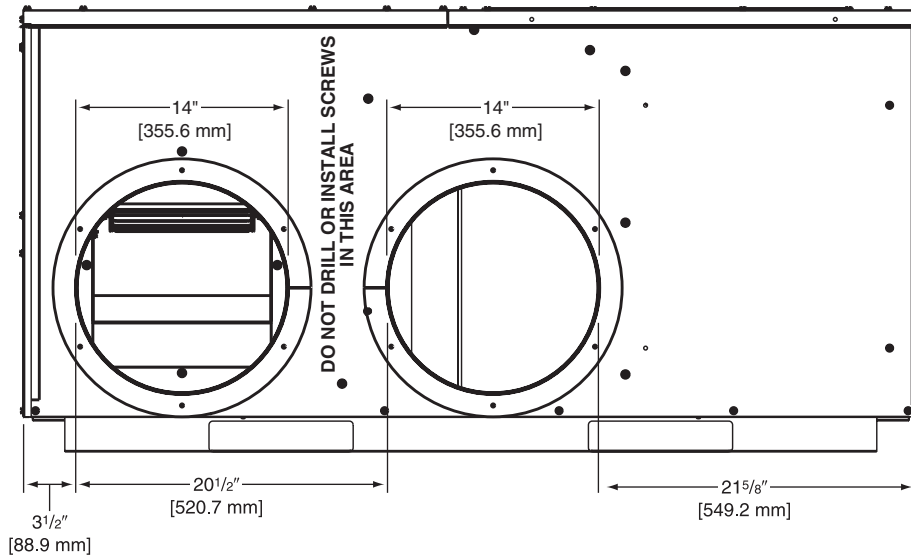

## SQUARE DUCT CONNECTIONS

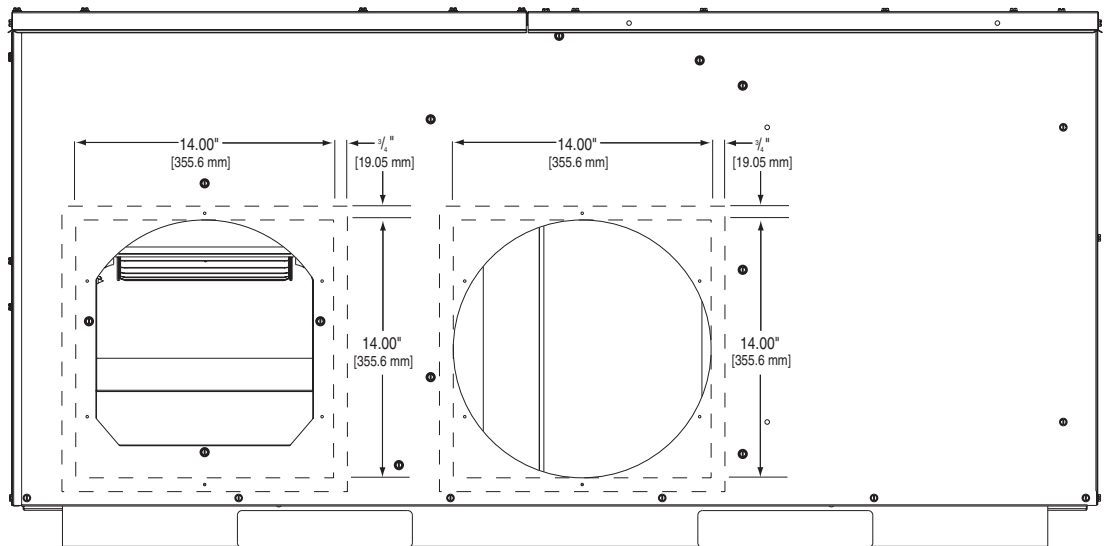

IMPORTANT: DO NOT SCREW OR DRILL OUTSIDE THE DESIGNATED AREAS.

## V. SPECIFICATIONS

Suitable for use in mobile homes, manufactured housing, and conventionally constructed residential and commercial buildings where horizontally-ducted systems are preferred.

---

## VI. INSTALLATION

### A. GENERAL

#### 1. PRE-INSTALLATION CHECK-POINTS

Before attempting any installation, the following points should be carefully considered:

- a. Structural strength of supporting members.  
(rooftop installation)
- b. Clearances and provision for servicing.
- c. Power supply and wiring.
- d. Air duct connections.
- e. Drain facilities and connections.
- f. Location for minimum noise.

#### 2. LOCATION

These units are designed for outdoor installations. They can be mounted on a slab or rooftop. They are not to be installed within any part of a structure such as an attic, crawl space, closet, or any other place where condenser air flow is restricted or other than outdoor ambient conditions prevail. Since the application of the units is of the outdoor type, it is important to consult your local code authorities at the time the first installation is made.

### B. OUTSIDE SLAB INSTALLATION

**(Typical outdoor slab installations are shown in Figure 2.)**

1. Select a location where external water drainage cannot collect around the unit.
2. Provide a level concrete slab extending 3" beyond all four sides of the unit. The slab should be sufficient above grade to prevent ground water from entering the unit.

**IMPORTANT:** To prevent transmission of noise or vibration, slab should not be connected to building structure.

3. The location of the unit should be such as to provide proper access for inspection and servicing.
4. Locate unit where operating sounds will not disturb owner or neighbors.
5. Locate unit so roof runoff water does not pour directly on the unit. Provide gutter or other shielding at roof level. Do not locate unit in an area where excessive snow drifting may occur or accumulate.
6. It is essential that the unit be elevated above the base pad to allow for condensate drainage and possible refreezing of condensation. Provide a base pad which is slightly pitched away from the structure. Route condensate off base pad to an area which will not become slippery and result in personal injury.

**IMPORTANT:** Avoid blocking openings in bottom of unit.

7. Where snowfall is anticipated, the height of the unit above the ground level must be considered. Mount unit high enough to be above average area snowfall and to allow for proper condensate drainage.

**IMPORTANT:** Avoid blocking openings in bottom of unit.

### C. CLEARANCES

The following minimum clearances must be observed for proper unit performance and serviceability.

1. Provide 30" minimum clearance at the front and 18" on the right side of the unit for service access. Provide 12" minimum clearance on the left side of the unit for air inlet.
2. Provide 60" minimum clearance from top of unit.
3. Unit is design certified for application on combustible flooring with 0" minimum clearance.
4. See Figure 2 for illustration of minimum installation-service clearances.

### D. ROOFTOP INSTALLATION

1. Before locating the unit on the roof, make sure that the strength of the roof and beams is adequate at that point to support the weight involved. (See specification sheet for weight of unit.) This is very important and user's responsibility.

**FIGURE 2**  
**PACKAGED HEAT PUMP**  
 OUTSIDE SLAB INSTALLATION, BASEMENT OR  
 CRAWL SPACE DISTRIBUTION SYSTEM

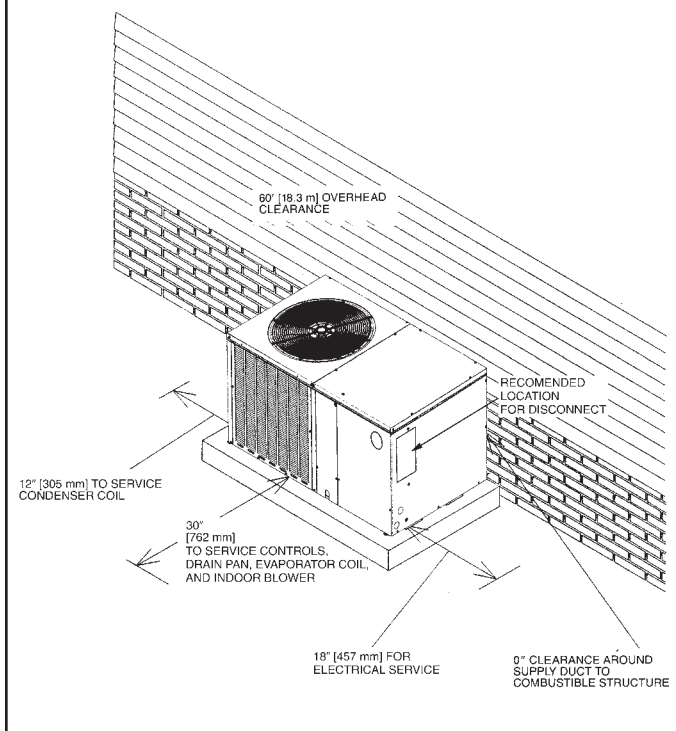

**FIGURE 3**  
**PACKAGED HEAT PUMP**  
 PITCHED ROOFTOP INSTALLATION, ATTIC  
 OR DROP CEILING DISTRIBUTING SYSTEM.  
 MUST BE MOUNTED LEVEL.

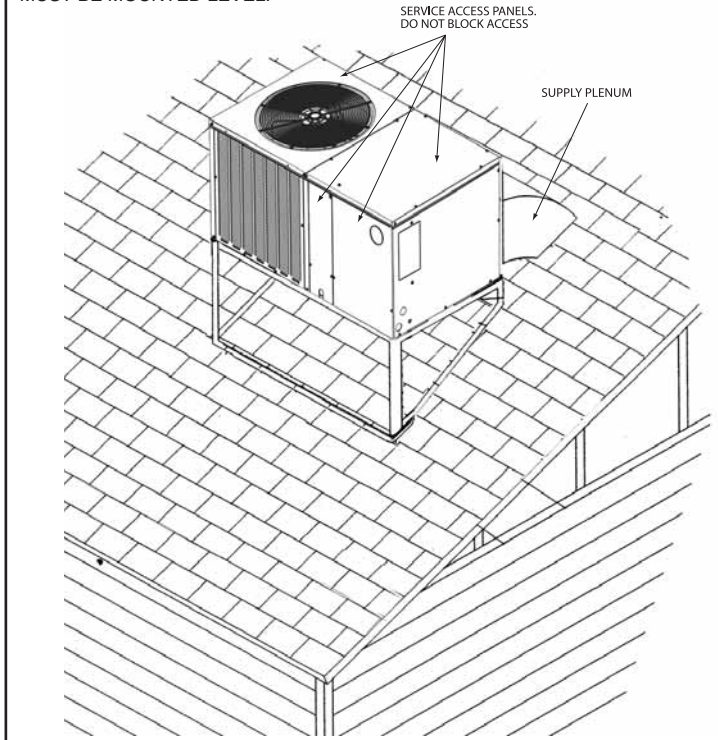

2. The unit should be placed on a solid and level platform of adequate strength.

**IMPORTANT:** Avoid blocking openings in bottom of unit. (See Figure 3). Provision for disposal of outdoor coil defrost water runoff must be provided.

3. The location of the unit on the roof should be such as to provide proper access for inspection and servicing.

**IMPORTANT:** If unit will not be put into service immediately, cover supply and return openings to prevent excessive condensation.

## VII. DUCTWORK

Ductwork should be fabricated by the installing contractor in accordance with local codes and NFPA90A. Industry manuals may be used as a guide when sizing and designing the duct system - contact Air Conditioning Contractors of America, 1513 16th St. N.W., Washington, D.C. 20036.

### **WARNING**

**DO NOT, UNDER ANY CIRCUMSTANCES, CONNECT RETURN DUCTWORK TO ANY OTHER HEAT PRODUCING DEVICE SUCH AS A FIREPLACE INSERT, STOVE, ETC. UNAUTHORIZED USE OF SUCH DEVICES MAY RESULT IN FIRE, CARBON MONOXIDE POISONING, EXPLOSION, PROPERTY DAMAGE, SEVERE PERSONAL INJURY OR DEATH.**

Place the unit as close to the space to be air conditioned as possible allowing clearance dimensions as indicated. Run ducts as directly as possible to supply and return outlets. Use of non-flammable waterproof flexible connectors on both supply and return connections at the unit to reduce noise transmission is recommended.

It is preferable to install the unit on the roof of the structure if the registers or diffusers are located on the wall or in the ceiling. Consider a slab installation when the registers are low on a wall or in the floor.

On ductwork exposed to outside air conditions of temperature and humidity, use a minimum of 2" of insulation and a vapor barrier. Distribution system in attic, furred space or crawl space should be insulated with at least 2" of insulation with vapor barrier. One-half to 1" thickness of insulation is usually sufficient for ductwork inside the air conditioned space.

Provide balancing dampers for each branch duct in the supply system. Properly support the ductwork from the structure.

## VIII. FILTERS

Filters are not provided with this unit. They must be supplied and installed in the return air duct by the installer. A field installed filter grille is recommended for easy and convenient access to the filters for periodic inspection and cleaning. Filters must have adequate face area for the rated air quantity of the unit. See General Database for recommended filter size.

## IX. CONDENSATE DRAIN

The indoor coil condensate drain ends with a PVC stub. A trap is provided in for proper condensate drainage and to prevent debris from being drawn into the unit. Do not connect drain to closed sewer line. It is not recommended that a PVC cement or other permanent installation be used so that the drain line and/or drain pan can be easily cleaned in the future. The drain trap is located in the control box during shipping. To install, slide clear plastic tube over drain pan connection. The white PVC trap can be oriented as required by installation.

## X. CONDENSATE DRAIN, OUTDOOR COIL

The outdoor coil during heating operation will sweat or run water off. The outdoor coil will also run water off during the defrost cycle. See Section V, Installation, for mounting precautions.

**FIGURE 4**  
REMOVABLE CONDENSATE DRAIN PAN AND REMOVAL PROCEDURE

A small side panel grants access to a removable, sloped drain pan (A), which helps to ensure indoor air quality (IAQ) throughout the life of the unit. A drain trap (B) assembly is provided for convenience.

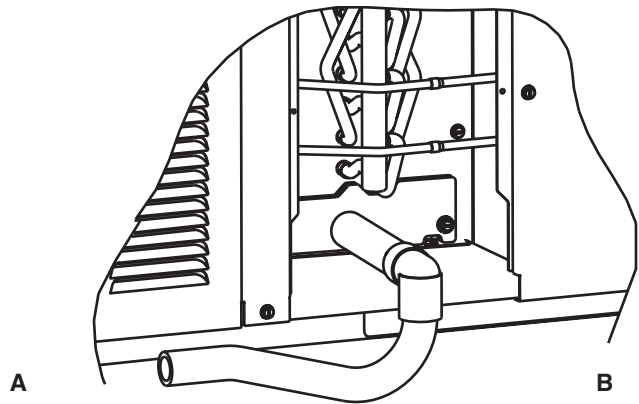

## XI. ELECTRICAL WIRING

Field wiring must comply with the National Electrical Code\* and applicable local codes.

\*C.E.C. in Canada

### A. POWER WIRING

1. It is important that proper electrical power is available at the unit. Voltage should not vary more than 10% from that stamped on the unit rating plate. On three phase units, phases must be balanced within 3%.
2. Install a branch circuit disconnect within sight of the unit and of adequate size to handle the starting current. (See Heater Kit Tables.)



## WARNING

TURN OFF ELECTRIC POWER AT THE FUSE BOX OR SERVICE PANEL BEFORE MAKING ANY ELECTRICAL CONNECTIONS.

ALSO, THE GROUND CONNECTION MUST BE COMPLETED BEFORE MAKING LINE VOLTAGE CONNECTIONS. FAILURE TO DO SO CAN RESULT IN ELECTRICAL SHOCK, SEVERE PERSONAL INJURY OR DEATH.

3. For branch circuit wiring (main power supply to unit disconnect), the minimum wire size can be determined from the National Electrical Code or Canadian Electrical Code or nameplate or from Heater Kit Tables.
4. This unit supports both single and dual point electrical connection for unit and electric heat accessory.
5. Power wiring must be run in grounded rain-tight conduit.

## B. POWER WIRING AND ELECTRIC HEATER KIT INSTRUCTIONS

1. Turn off power to unit.
2. Remove control box access panel.
3. Remove unit indoor section top cover.
4. Remove wire notch cover from control bulkhead and discard. Retain screw.
5. Remove heater element cover plate from blower outlet opening and discard. Retain screws.
6. Mount heater fuse block assembly in location indicated with the three included screws.
7. Route wire harness assembly through wire notch in control bulkhead and mount element assembly in blower outlet opening with screws previously retained.
8. Center wire routing plate over notch in blower bulkhead and secure with screw previously retained.
9. Route and tie wiring as shown in Figure 5. Wiring must not contact moving parts or uninsulated electrical connections.
10. Replace unit indoor top cover.
11. Connect power and control wiring as indicated below:
  - a. **Single-point wiring:** Connect high voltage field power leads to heater kit fuse block and connect included unit power pigtailed from heater kit fuse block to unit contactor L1 and L3 connections. Connect ground lead to ground lug on heater kit fuse block.
  - b. **Dual-circuit wiring:** Remove unit power pigtailed from heater kit fuse block and discard. Connect one set of high voltage field power circuit leads to the heater kit fuse block and connect ground lead to ground lug on heater kit fuse block.  
Connect the second set of high voltage field power leads to L1 and L3 on the unit contactor. Connect ground lead to ground lug on control box bulkhead.
  - c. Connect heater kit control plug to receptacle in control box.
12. Replace control box access panel.
13. Restore power to unit and verify proper unit and heater kit operation.

## C. CONTROL WIRING (Class II)

1. Do not run low voltage wiring in conduit with power wiring.
2. Control wiring is routed through the 7/8" hole corner adjacent to the control box. See Electrical Connections, Figure 1. Use a minimum #18 AWG thermostat wire. For wire lengths exceeding 50', use #16 AWG thermostat wire. The low voltage wires are connected to the unit pigtailed which are supplied with the unit in the low voltage connection box located within the unit control box. See Figure 5.
3. It is necessary that only heat pump thermostats be used.

RECOMMENDED HEAT PUMP THERMOSTATS		
Rheem Part Number	Type	Manufacturer's Model Number
41-20796-28	Mechanical	Honeywell T874R1442
41-20796-24	Sub-base for 41-20796-28	Honeywell Q674L1504
41-20804-15	Mechanical	General Electric 3AAT86B8A1
41-25090-02	Electronic	Honeywell T8411R1051
41-23952-01	Electronic	Robertshaw 09520
41-21594-05	Electronic set-back, 5-1-1 day	Honeywell T8611R1034
41-1F95-377	Electronic set-back, 5-2 day	White-Rodgers 1F92-71
41-25090-06	Electronic set-back, 7-day	Honeywell T8611G2093
41-23962-21	Electronic set-back, 7-day	Robertshaw 09620

4. Figure 6 shows representative low voltage connection diagrams. Read your thermostat installation instructions for any special requirements for your specific thermostat.

**FIGURE 5**  
HEATER KIT INSTALLATION

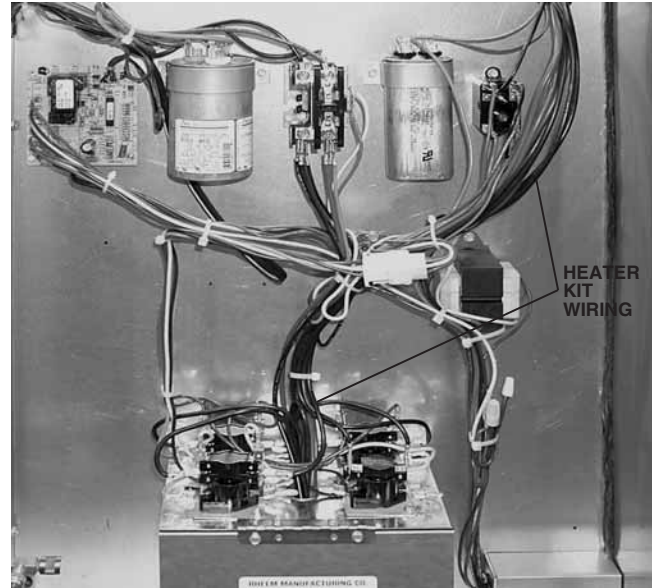

**NOTE** — Units installed in Canada require that an outdoor thermostat (30,000 min. cycles of endurance) be installed and be wired with C.E.C. Class I wiring.

#### **D. INTERNAL WIRING**

1. A diagram of the internal wiring of this unit is located on the electrical control box cover. If any of the original wire as supplied with the appliance must be replaced, the wire gauge and insulation must be the same as original wiring.

#### **E. GROUNDING**

##### **⚠ WARNING**

**THE UNIT MUST BE PERMANENTLY GROUNDED. A GROUNDING LUG IS PROVIDED. FAILURE TO GROUND THIS UNIT CAN RESULT IN FIRE OR ELECTRICAL SHOCK CAUSING PROPERTY DAMAGE, SEVERE PERSONAL INJURY OR DEATH.**

#### **F. THERMOSTAT**

Mount the thermostat on an inside wall about five feet above the floor in a location where it will not be affected by unconditioned air, sun, or drafts from open doors or other sources. READ installation instructions in heat pump thermostat package CAREFULLY because each has some different wiring requirements.

## **XII. INDOOR AIR FLOW DATA**

All 208/230 volt units are equipped with multi-speed indoor blower motors. Each unit is shipped factory wired for the proper speed at a normal external static. See Airflow Performance Table for blower performance.

## **XIII. PRE-START CHECK**

1. Is unit properly located and level?
2. Is ductwork insulated, weatherproofed, with proper spacing to combustible materials?
3. Is air free to travel to and from outdoor coil? (See Figure 1.)

**FIGURE 6**  
VOLTAGE CONNECTIONS DIAGRAM

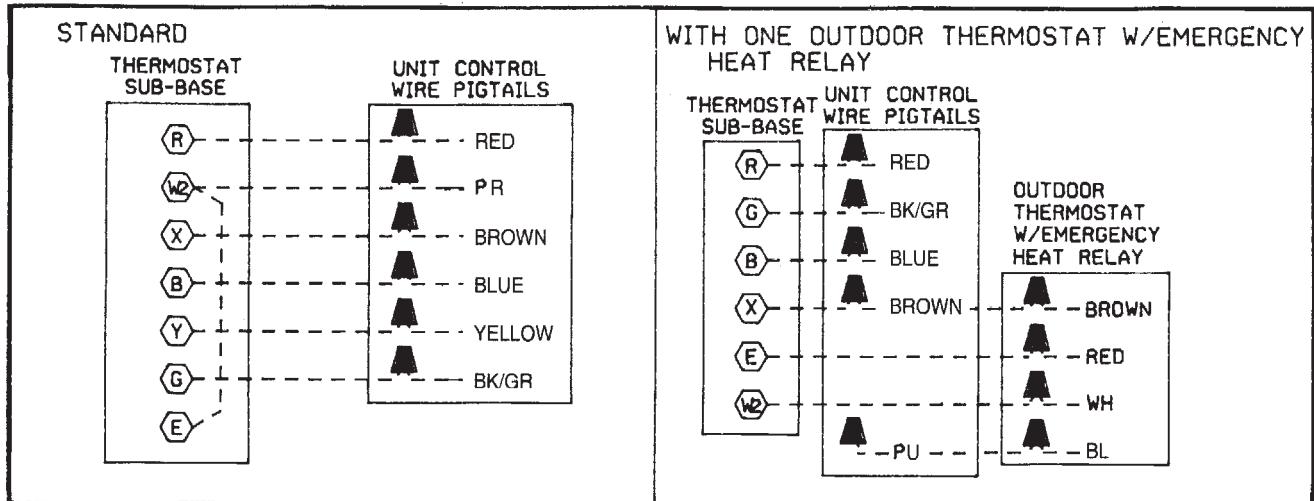

IF EMERGENCY HEAT RELAY AND OUTDOOR THERMOSTATS ARE NOT USED, A JUMPER BETWEEN 'W2' AND 'E' CAN BE INSTALLED TO TRANSFER CONTROL OF HEATING TO THE FIRST STAGE WHEN THE SYSTEM SWITCH IS IN THE EMERGENCY HEAT POSITION.

4. Is the wiring correct, tight, and according to unit wiring diagram?
5. Is unit grounded?
6. Are field supplied air filters in place and clean?
7. Do the outdoor fan and indoor blower turn freely without rubbing, and are they tight on the motor shafts?
8. Has crankcase heat been on for at least 12 hours?
9. Is unit elevated to allow for outdoor coil condensate drainage during heating operation and defrost?

## XIV. STARTUP

1. Turn thermostat to "OFF," turn "on" power supply at disconnect switch.
2. Turn temperature setting as high as it will go.
3. Turn fan switch to "ON."
4. Indoor blower should run. Be sure it is running in the right direction.
5. Turn fan switch to "AUTO." Turn system switch to "COOL" and turn temperature setting below room temperature. Unit should run in cooling mode.
6. Is outdoor fan operating correctly in the right direction?
7. Is compressor running correctly.
8. Turn thermostat system switch to "HEAT." Unit should stop. Wait 5 minutes, then raise temperature setting to above room temperature. Unit should run in heating mode and after about 30 to 50 seconds auxiliary heaters, if installed, should come on.
9. Check the refrigerant charge using the instructions located on control box cover. Replace service port caps. Service port cores are for system access only and will leak if not tightly capped.
10. Turn thermostat system switch to proper mode "HEAT" or "COOL" and set thermostat to proper temperature setting. Record the following after the unit has run some time.
  - A. Operating Mode \_\_\_\_\_
  - B. Discharge Pressure (High) \_\_\_\_\_ PSIG
  - C. Vapor Pressure at Compressor (Low) \_\_\_\_\_ PSIG
  - D. Vapor Line Temperature at Compressor \_\_\_\_\_ °F.
  - E. Indoor Dry Bulb \_\_\_\_\_ °F.
  - F. Indoor Wet Bulb \_\_\_\_\_ °F.
  - G. Outdoor Dry Bulb \_\_\_\_\_ °F.
  - H. Outdoor Wet Bulb \_\_\_\_\_ °F.
  - I. Voltage at Contactor \_\_\_\_\_ Volts
  - J. Current at Contactor \_\_\_\_\_ Amps
  - K. Model Number \_\_\_\_\_

L. Serial Number \_\_\_\_\_  
M. Location \_\_\_\_\_  
N. Owner \_\_\_\_\_  
O. Date \_\_\_\_\_

11. Adjust discharge air grilles and balance system.
12. Check ducts for condensation and air leaks.
13. Check unit for tubing and sheet metal rattles.
14. Instruct the owner on operation and maintenance.
15. Leave "USE AND CARE" instructions with owner.

---

## XV. OPERATION

Most single phase units are not equipped with start relay or start capacitor. It is important that such systems be off for a minimum of 5 minutes before restarting to allow equalization of pressures. Do not move the thermostat to cycle unit without waiting five minutes. To do so may cause the compressor to stop on an automatic open overload device or blow a fuse. Poor electrical service can cause nuisance tripping in overloads or blow fuses.

**IMPORTANT:** *The compressor has an internal overload protector. Under some conditions, it can take up to 2 hours for this overload to reset. Make sure overload has had time to reset before condemning the compressor.*

These units are equipped with a time delay control (TDC1). The control allows the blower to operate for 45 to 90 seconds after the thermostat is satisfied.

---

## XVI. AUXILIARY HEAT

The amount of auxiliary heat required depends on the heat loss of the structure to be heated and the capacity of the heat pump. It is good practice to install strip heat to maintain at least 60°F indoor temperatures in case of compressor failure. The auxiliary heat is energized by the first stage of the thermostat. The amount of electric heat that is allowed to come on, as determined by the output of the heat pump, may be controlled by an outdoor thermostat.

### WARNING

**ONLY ELECTRIC HEATER KITS SUPPLIED BY THIS MANUFACTURER AS DESCRIBED IN THIS PUBLICATION HAVE BEEN DESIGNED, TESTED, AND EVALUATED BY A NATIONALLY RECOGNIZED SAFETY TESTING AGENCY FOR USE WITH THIS UNIT. USE OF ANY OTHER MANUFACTURED ELECTRIC HEATERS INSTALLED WITHIN THIS UNIT MAY CAUSE HAZARDOUS CONDITIONS RESULTING IN PROPERTY DAMAGE, FIRE, BODILY INJURY OR DEATH.**

### A. CONTROL SYSTEM OPERATION

1. In the cooling mode, the thermostat will, on a call for cooling, energize the compressor contactor and the indoor blower relay. The indoor blower can be operated continuously by setting the thermostat fan switch at the "ON" position.
2. In the heating mode, the first heat stage of the thermostat will energize one or more supplementary resistance heaters. If required or considered desirable, the resistance heat may also be controlled by outdoor thermostats. In the heating mode, the thermostat will, on a call for heating, energize the indoor blower relay.

---

## XVII. DEMAND DEFROST CONTROL

The demand defrost control is a printed circuit board assembly consisting of solid state control devices with electro-mechanical outputs. The demand defrost control monitors the outdoor ambient temperature, outdoor coil temperature, and the compressor run-time to determine when a defrost cycle is required.

## DEFROST INITIATION

A defrost will be initiated when the three conditions below are satisfied:

- 1) The outdoor coil temperature is below 35°F.
- 2) The compressor has operated for at least 34 minutes with the outdoor coil temperature below 35°F.
- 3) The measured difference between the ambient temperature and the outdoor coil temperature is greater than the calculated delta T.

Additionally, a defrost will be initiated if six hours of accumulated compressor runtime has elapsed without a defrost with the outdoor coil temperature below 35°F.

## DEFROST TERMINATION

Once a defrost is initiated, the defrost will continue until fourteen minutes has elapsed **or** the coil temperature has reached the terminate temperature. The terminate temperature is factory set at 70°F, although the temperature can be changed to 50°F, 60°F, 70°F or 80°F by relocating a jumper on the board.

## TEMPERATURE SENSORS

The coil sensor is clipped to a tube on the outdoor coil at the point fed by the distribution tubes from the expansion device (short 3/8" dia. tube). The air sensor is located behind the compressor access panel.

If the ambient sensor fails the defrost control will initiate a defrost every 34 minutes with the coil temperature below 35°F.

If the coil sensor fails the defrost control will not initiate a defrost.

## TEST MODE

The test mode is initiated by shorting the TEST pins. In this mode of operation, the enable temperature is ignored and all timers are sped up by a factor of 240. To initiate a manual defrost, short the TEST pins. Remove the short when the system switches to defrost mode. The defrost will terminate on time (14 minutes) or when the termination temperature has been achieved. *Short TEST pins again to terminate the defrost immediately.*

## TROUBLE SHOOTING DEMAND DEFROST

Set the indoor thermostat select switch to heat and thermostat lever to a call for heat.

Jumper the "test pins" to put the unit into defrost. If the unit goes into defrost and comes back out of defrost, the indication is that the control is working properly.

If the unit did not go into defrost using the test pins, check to ensure that 24V is being supplied to the control board. If 24V is present then replace the control.

# XVIII. GENERAL DATA - RQNJ

## NOMINAL SIZES 2-5 TONS [7-17.6 kW]

Model RQNJ- Series	A024JK	A030JK	A036CK	A036JK
<b>Cooling Performance<sup>1</sup></b>				Continued ->
Gross Cooling Capacity Btu [kW]	25,000 [7.3]	30,000 [8.8]	37,000 [10.8]	37,000 [10.8]
EER/SEER <sup>2</sup>	11.2/13	11.25/13	11.45/13	11.45/13
Nominal CFM/ARI Rated CFM [L/s]	800/800 [378/378]	1000/1000 [472/472]	1200/1200 [566/566]	1200/1200 [566/566]
ARI Net Cooling Capacity Btu [kW]	24,000 [7]	29,000 [8.5]	35,600 [10.4]	35,600 [10.4]
Net Sensible Capacity Btu [kW]	18,200 [5.3]	22,400 [6.6]	27,200 [8]	27,200 [8]
Net Latent Capacity Btu [kW]	5800 [1.7]	6600 [1.9]	8400 [2.5]	8400 [2.5]
Net System Power kW	2.1	2.5	3	3
<b>Heating Performance (Heat Pumps)</b>				
High Temp. Btuh [kW] Rating	24,000 [7]	28,800 [8.4]	36,000 [10.5]	36,000 [10.5]
System Power KW / COP	'2.2/3.26	'2.5/3.24	'3.1/3.34	'3.1/3.34
Low Temp. Btuh [kW] Rating	14,400 [4.2]	16,600 [4.9]	20,400 [6]	20,400 [6]
System Power KW / COP	'1.9/2.18	'2.4/2.08	'2.8/2.14	'2.8/2.14
HSPF (Btu/Watts-hr)	7.7	7.7	7.7	7.7
<b>Compressor</b>				
No./Type	1/Copeland Scroll	1/Copeland Scroll	1/Copeland Scroll	1/Copeland Scroll
<b>Outdoor Sound Rating (dB)<sup>5</sup></b>	76	76	76	76
<b>Outdoor Coil - Fin Type</b>	Louvered	Louvered	Louvered	Louvered
Tube Type	Rifled	Rifled	Rifled	Rifled
Tube Size in. [mm] OD	0.375 [9.5]	0.375 [9.5]	0.375 [9.5]	0.375 [9.5]
Face Area sq. ft. [sq. m]	10.44 [0.97]	12.65 [1.18]	10.44 [0.97]	10.44 [0.97]
Rows / FPI [FPcm]	1 / 20 [8]	1 / 20 [8]	2 / 16 [6]	2 / 16 [6]
Refrigerant Control	TX Valves	TX Valves	TX Valves	TX Valves
<b>Indoor Coil - Fin Type</b>	Louvered	Louvered	Louvered	Louvered
Tube Type	Rifled	Rifled	Rifled	Rifled
Tube Size in. [mm]	0.375 [9.5]	0.375 [9.5]	0.375 [9.5]	0.375 [9.5]
Face Area sq. ft. [sq. m]	4.33 [0.4]	4.33 [0.4]	4.33 [0.4]	4.33 [0.4]
Rows / FPI [FPcm]	2 / 15 [6]	2 / 15 [6]	3 / 13 [5]	3 / 13 [5]
Refrigerant Control	TX Valves	TX Valves	TX Valves	TX Valves
Drain Connection No./Size in. [mm]	1/1 [25.4]	1/1 [25.4]	1/1 [25.4]	1/1 [25.4]
<b>Outdoor Fan - Type</b>	Propeller	Propeller	Propeller	Propeller
No. Used/Diameter in. [mm]	1/24 [609.6]	1/24 [609.6]	1/24 [609.6]	1/24 [609.6]
Drive Type/No. Speeds	Direct/1	Direct/1	Direct/1	Direct/1
CFM [L/s]	3200 [1510]	3200 [1510]	3200 [1510]	3200 [1510]
No. Motors/HP	1 at 1/3 HP	1 at 1/3 HP	1 at 1/3 HP	1 at 1/3 HP
Motor RPM	1075	1075	1075	1075
<b>Indoor Fan - Type</b>	FC Centrifugal	FC Centrifugal	FC Centrifugal	FC Centrifugal
No. Used/Diameter in. [mm]	1/10x9 [254x228.6]	1/10x9 [254x228.6]	1/10x9 [254x228.6]	1/10x9 [254x228.6]
Drive Type/No. Speeds	Direct/2	Direct/2	Direct/2	Direct/2
No. Motors	1	1	1	1
Motor HP	1/4	1/3	1/2	1/2
Motor RPM	1033	1080	1050	1050
Motor Frame Size	48	48	48	48
<b>Filter - Type</b>	Field Supplied	Field Supplied	Field Supplied	Field Supplied
Furnished	No	No	No	No
(NO.) Size Recommended in. [mm x mm x mm]	(1)1x20x16 [25x508x406]	(1)1x20x20 [25x508x508]	(1)1x24x24 [25x610x610]	(1)1x24x24 [25x610x610]
<b>Refrigerant Charge Oz. [g]</b>	70 [1984]	76 [2155]	121 [3430]	121 [3430]
<b>Weights</b>				
Net Weight lbs. [kg]	308 [140]	331 [150]	356 [161]	356 [161]
Ship Weight lbs. [kg]	332 [151]	355 [161]	380 [172]	380 [172]

# GENERAL DATA - RQNJ

## NOMINAL SIZES 2-5 TONS [7-17.6 kW]

Model RQNJ- Series	A042CK	A042JK	A048CK	A048JK
<b>Cooling Performance<sup>1</sup></b>				Continued ->
Gross Cooling Capacity Btu [kW]	43,500 [12.7]	43,500 [12.7]	49,000 [14.4]	49,000 [14.4]
EER/SEER <sup>2</sup>	11.85/13	11.85/13	11.4/13	11.4/13
Nominal CFM/ARI Rated CFM [L/s]	1400/1450 [661/684]	1400/1450 [661/684]	1600/1550 [755/731]	1600/1550 [755/731]
ARI Net Cooling Capacity Btu [kW]	42,000 [12.3]	42,000 [12.3]	47,000 [13.8]	47,000 [13.8]
Net Sensible Capacity Btu [kW]	32,200 [9.4]	32,200 [9.4]	35,600 [10.4]	35,600 [10.4]
Net Latent Capacity Btu [kW]	9800 [2.9]	9800 [2.9]	11,400 [3.3]	11,400 [3.3]
Net System Power kW	3.5	3.5	4.1	4.1
<b>Heating Performance (Heat Pumps)</b>				
High Temp. Btuh [kW] Rating	40,500 [11.9]	40,500 [11.9]	47,000 [13.8]	47,000 [13.8]
System Power KW / COP	'3.3/3.4	'3.3/3.4	'4.1/3.36	'4.1/3.36
Low Temp. Btuh [kW] Rating	23,000 [6.7]	23,000 [6.7]	27,600 [8.1]	27,600 [8.1]
System Power KW / COP	'3.1/2.2	'3.1/2.2	'3.6/2.2	'3.6/2.2
HSPF (Btu/Watts-hr)	7.7	7.7	7.7	7.7
<b>Compressor</b>				
No./Type	1/Copeland Scroll	1/Copeland Scroll	1/Copeland Scroll	1/Copeland Scroll
<b>Outdoor Sound Rating (dB)<sup>5</sup></b>	78	78	78	78
<b>Outdoor Coil - Fin Type</b>	Louvered	Louvered	Louvered	Louvered
Tube Type	Rifled	Rifled	Rifled	Rifled
Tube Size in. [mm] OD	0.375 [9.5]	0.375 [9.5]	0.375 [9.5]	0.375 [9.5]
Face Area sq. ft. [sq. m]	13.65 [1.27]	13.65 [1.27]	13.65 [1.27]	13.65 [1.27]
Rows / FPI [FPcm]	2 / 18 [7]	2 / 18 [7]	2 / 18 [7]	2 / 18 [7]
Refrigerant Control	TX Valves	TX Valves	TX Valves	TX Valves
<b>Indoor Coil - Fin Type</b>	Louvered	Louvered	Louvered	Louvered
Tube Type	Rifled	Rifled	Rifled	Rifled
Tube Size in. [mm]	0.375 [9.5]	0.375 [9.5]	0.375 [9.5]	0.375 [9.5]
Face Area sq. ft. [sq. m]	5.78 [0.54]	5.78 [0.54]	5.78 [0.54]	5.78 [0.54]
Rows / FPI [FPcm]	3 / 13 [5]	3 / 13 [5]	3 / 13 [5]	3 / 13 [5]
Refrigerant Control	TX Valves	TX Valves	TX Valves	TX Valves
Drain Connection No./Size in. [mm]	1/1 [25.4]	1/1 [25.4]	1/1 [25.4]	1/1 [25.4]
<b>Outdoor Fan - Type</b>	Propeller	Propeller	Propeller	Propeller
No. Used/Diameter in. [mm]	1/24 [609.6]	1/24 [609.6]	1/24 [609.6]	1/24 [609.6]
Drive Type/No. Speeds	Direct/1	Direct/1	Direct/1	Direct/1
CFM [L/s]	4200 [1982]	4200 [1982]	4200 [1982]	4200 [1982]
No. Motors/HP	1 at 1/3 HP	1 at 1/3 HP	1 at 1/3 HP	1 at 1/3 HP
Motor RPM	1075	1075	1075	1075
<b>Indoor Fan - Type</b>	FC Centrifugal	FC Centrifugal	FC Centrifugal	FC Centrifugal
No. Used/Diameter in. [mm]	1/11x9 [279.4x228.6]	1/11x9 [279.4x228.6]	1/11x9 [279.4x228.6]	1/11x9 [279.4x228.6]
Drive Type/No. Speeds	Direct/2	Direct/2	Direct/2	Direct/2
No. Motors	1	1	1	1
Motor HP	1/2	1/2	3/4	3/4
Motor RPM	1075	1075	1075	1075
Motor Frame Size	48	48	48	48
<b>Filter - Type</b>	Field Supplied	Field Supplied	Field Supplied	Field Supplied
Furnished	No	No	No	No
(NO.) Size Recommended in. [mm x mm x mm]	(1)1x24x24 [25x610x610]	(1)1x24x24 [25x610x610]	(1)1x24x24 [25x610x610]	(1)1x24x24 [25x610x610]
<b>Refrigerant Charge Oz. [g]</b>	156 [4423]	156 [4423]	158 [4479]	158 [4479]
<b>Weights</b>				
Net Weight lbs. [kg]	408 [185]	408 [185]	429 [195]	429 [195]
Ship Weight lbs. [kg]	434 [197]	434 [197]	455 [206]	455 [206]

# GENERAL DATA - RQNJ

## NOMINAL SIZES 2-5 TONS [7-17.6 kW]

Model RQNJ- Series	A060CK	A060JK	B060CK	B060JK
<b>Cooling Performance<sup>1</sup></b>				
Gross Cooling Capacity Btu [kW]	62,000 [18.2]	62,000 [18.2]	62,000 [18.17]	62,000 [18.17]
EER/SEER <sup>2</sup>	11.45/13	11.45/13	11.45/13	11.45/13
Nominal CFM/ARI Rated CFM [L/s]	2000/1900 [944/897]	2000/1900 [944/897]	2000/1900 [944/897]	2000/1900 [944/897]
ARI Net Cooling Capacity Btu [kW]	59,000 [17.3]	59,000 [17.3]	59,000 [17.29]	59,000 [17.29]
Net Sensible Capacity Btu [kW]	44,600 [13.1]	44,600 [13.1]	44,600 [13.07]	44,600 [13.07]
Net Latent Capacity Btu [kW]	14,400 [4.2]	14,400 [4.2]	14,400 [4.22]	14,400 [4.22]
Net System Power kW	5.1	5.1	5.11	5.11
<b>Heating Performance (Heat Pumps)</b>				
High Temp. Btuh [kW] Rating	57,500 [16.8]	57,500 [16.8]	57,500 [16.85]	57,500 [16.85]
System Power KW / COP	'4.8/3.48	'4.8/3.48	4.76/3.48	4.76/3.48
Low Temp. Btuh [kW] Rating	33,600 [9.8]	33,600 [9.8]	33,600 [9.84]	33,600 [9.84]
System Power KW / COP	'4.2/2.34	'4.2/2.34	4.21/2.34	4.21/2.34
HSPF (Btu/Watts-hr)	7.7	7.7	7.7	7.7
<b>Compressor</b>				
No./Type	1/Copeland Scroll	1/Copeland Scroll	1/Copeland Scroll	1/Copeland Scroll
<b>Outdoor Sound Rating (dB)<sup>5</sup></b>				
	78	78	78	78
<b>Outdoor Coil - Fin Type</b>				
Tube Type	Rifled	Rifled	Rifled	Rifled
Tube Size in. [mm] OD	0.375 [9.5]	0.375 [9.5]	0.375 [9.5]	0.375 [9.5]
Face Area sq. ft. [sq. m]	16.54 [1.54]	16.54 [1.54]	16.54 [1.54]	16.54 [1.54]
Rows / FPI [FPcm]	2 / 18 [7]	2 / 18 [7]	2 / 18 [7]	2 / 18 [7]
Refrigerant Control	TX Valves	TX Valves	TX Valves	TX Valves
<b>Indoor Coil - Fin Type</b>				
Tube Type	Rifled	Rifled	Rifled	Rifled
Tube Size in. [mm]	0.375 [9.5]	0.375 [9.5]	0.375 [9.5]	0.375 [9.5]
Face Area sq. ft. [sq. m]	5.78 [0.54]	5.78 [0.54]	5.78 [0.54]	5.78 [0.54]
Rows / FPI [FPcm]	4 / 13 [5]	4 / 13 [5]	4 / 13 [5]	4 / 13 [5]
Refrigerant Control	TX Valves	TX Valves	TX Valves	TX Valves
Drain Connection No./Size in. [mm]	1/1 [25.4]	1/1 [25.4]	1/1 [25.4]	1/1 [25.4]
<b>Outdoor Fan - Type</b>				
No. Used/Diameter in. [mm]	1/24 [609.6]	1/24 [609.6]	1/24 [609.6]	1/24 [609.6]
Drive Type/No. Speeds	Direct/1	Direct/1	Direct/1	Direct/1
CFM [L/s]	4000 [1888]	4000 [1888]	4000 [1888]	4000 [1888]
No. Motors/HP	1 at 1/3 HP	1 at 1/3 HP	1 at 1/3 HP	1 at 1/3 HP
Motor RPM	1075	1075	1075	1075
<b>Indoor Fan - Type</b>				
No. Used/Diameter in. [mm]	FC Centrifugal 1/11x9 [279.4x228.6]	FC Centrifugal 1/11x9 [279.4x228.6]	FC Centrifugal 1/11x9 [279.4x228.6]	FC Centrifugal 1/11x9 [279.4x228.6]
Drive Type/No. Speeds	Direct/2	Direct/2	Direct/2	Direct/2
No. Motors	1	1	1	1
Motor HP	1	1	1	1
Motor RPM	1075	1075	1075	1075
Motor Frame Size	48	48	48	48
<b>Filter - Type</b>				
Furnished	Field Supplied	Field Supplied	Field Supplied	Field Supplied
(NO.) Size Recommended in. [mm x mm x mm]	(1)1x24x24 [25x610x610]	(1)1x24x24 [25x610x610]	(1)1x24x24 [25x610x610]	(1)1x24x24 [25x610x610]
<b>Refrigerant Charge Oz. [g]</b>				
	195 [5528]	195 [5528]	195 [5528]	195 [5528]
<b>Weights</b>				
Net Weight lbs. [kg]	481 [218]	481 [218]	481 [218]	481 [218]
Ship Weight lbs. [kg]	507 [230]	507 [230]	507 [230]	507 [230]



# XIX. MISCELLANEOUS

## ELECTRICAL AND PHYSICAL DATA

Model No. RQNJ-	Unit Information				Evaporator Fan					
	Unit Operating Voltage Range	Minimum Circuit Ampacity	Minimum Overcurrent Protection Device Size	Maximum Overcurrent Protection Device Size	No.	Volts	Phase	HP	Amps (FLA)	Amps (LRA)
A024JK	187-253	17/17	20/20	25/25	1	208/230	1	1/4	1.5	2.6
A030JK	187-253	19/19	25/25	30/30	1	208/230	1	1/3	1.7	2.6
A036CK	187-253	16/16	20/20	25/25	1	208/230	1	1/2	2.5	5
A036JK	187-253	23/23	30/30	35/35	1	208/230	1	1/2	2.5	5
A042CK	187-253	18/18	25/25	30/30	1	208/230	1	1/2	2.7	4.6
A042JK	187-253	26/26	30/30	40/40	1	208/230	1	1/2	2.7	4.6
A048CK	187-253	22/22	25/25	30/30	1	208/230	1	3/4	3.2	4.4
A048JK	187-253	28/28	35/35	45/45	1	208/230	1	3/4	3.2	4.4
A060CK	187-253	31/31	35/35	45/45	1	208/230	1	1	7	0
A060JK	187-253	41/41	50/50	60/60	1	208/230	1	1	7	0
B060CK	187-253	32/32	35/35	45/45	1	208/230	1	1	7.6	0
B060JK	187-253	41/41	50/50	60/60	1	208/230	1	1	7.6	0

## ELECTRICAL AND PHYSICAL DATA

Model No. RQNJ-	Compressor Motor							Condenser Motor					
	No.	Volts	Phase	HP <sup>2</sup>	RPM	Amps <sup>1</sup>	Amps <sup>1</sup>	No.	Volts	Phase	HP <sup>2</sup>	Amps <sup>1</sup> (FLA)	Amps <sup>1</sup> (LRA)
A024JK	1	208/230	1	2	3450	10.9/10.9	54/54	1	208/230	1	1/3	1.5	3
A030JK	1	208/230	1	2.5	3450	12.2/12.2	67/67	1	208/230	1	1/3	1.5	3
A036CK	1	208/230	3	3	3450	10.2/10.2	63/63	1	208/230	1	1/3	1.5	3
A036JK	1	208/230	1	3	3450	14.9/14.9	83/83	1	208/230	1	1/3	1.5	3
A042CK	1	208/230	3	3.5	3450	11.6/11.6	77/77	1	208/230	1	1/3	1.8	4
A042JK	1	208/230	1	3.5	3450	16.7/16.7	95/95	1	208/230	1	1/3	1.8	4
A048CK	1	208/230	3	4	3450	12.9/12.9	88/88	1	208/230	1	1/3	1.8	4
A048JK	1	208/230	1	4	3450	18.3/18.3	109/109	1	208/230	1	1/3	1.8	4
A060CK	1	208/230	3	4.5	3450	17.3/17.3	123/123	1	208/230	1	1/3	1.8	4
A060JK	1	208/230	1	4.5	3450	25/25	148/148	1	208/230	1	1/3	1.8	4
B060CK	1	208/230	3	4.5	3450	17.3/17.3	123/123	1	208/230	1	1/3	1.8	4
B060JK	1	208/230	1	4.5	3450	25/25	148/148	1	208/230	1	1/3	1.8	4

# INDOOR AIR-FLOW PERFORMANCE FOR 2-5 TON PACKAGE HEAT Pumps

Nominal Cooling Capacity Tons	Motor Speed From Factory	Manufacturer Recommended Air Flow Range (Min / Max) CFM	Blower Size/ Motor HP # of Speeds	Motor Speed	CFM Air Delivery/RPM/Watts-230 Volts											
					External Static Pressure-Inches W.C.											
					0.10	0.20	0.30	0.40	0.50	0.60	0.70	0.80	0.90	1.00		
2.0	Low	700 / 900	10x9 1/4 2 Speed	Low	CFM	827	811	782	740	684	614	531	435			
					RPM	450	533	626	742	799	894	932	985			
					Watts	278	273	269	254	244	227	216	198			
	High				High	CFM	1230	1223	1216	1211	1187	1125	1020	874	696	504
						RPM	575	643	703	767	819	877	976	1001	1072	1092
						Watts	479	468	455	448	431	416	357	341	279	259
2.5	Low	875 / 1125	10x9 1/3 2 Speed	Low	CFM	1032	1030	1014	979	923	843	735	596	423		
					RPM	533	570	659	746	795	863	934	1019	1050		
					Watts	336	331	326	314	303	280	271	227	210		
	High				High	CFM	1312	1301	1292	1276	1246	1196	1117	1003	845	
						RPM	592	646	712	768	824	883	933	1012	1035	
						Watts	482	473	466	454	433	421	401	349	329	
3.0	Low	1050 / 1350	10x9 1/2 2 Speed	Low	CFM	1261	1253	1225	1177	1110	1023	915	788	641		
					RPM	648	705	754	802	854	896	985	1008	1041		
					Watts	398	395	387	391	370	361	323	310	300		
	High				High	CFM	2068	2008	1957	1905	1841	1753	1629	1458	1228	929
						RPM	850	883	917	946	972	999	1028	1049	1091	1108
						Watts	826	806	784	762	734	702	658	626	546	512
3.5	Low	1225 / 1575	11x9 1/2 2 Speed	Low	CFM	1431	1394	1348	1302	1258	1208	1140	1030	849	557	
					RPM	540	579	633	686	724	776	831	868	1035	1076	
					Watts	482	479	477	470	459	453	437	423	335	292	
	High				High	CFM	1960	1936	1903	1859	1806	1742	1669	1585	1491	1387
						RPM	703	727	750	780	809	846	877	910	940	975
						Watts	783	782	776	759	750	729	712	686	656	625
4.0	Low	1400 / 1800	11x9 3/4 2 Speed	Low	CFM	1674	1638	1595	1547	1492	1432	1365	1293	1214	1129.1	
					RPM	576	618	668	708	753	789	832	874	915	954	
					Watts	575	563	556	549	544	532	522	503	483	465	
	High				High	CFM	1996	1976	1947	1909	1863	1808	1744	1671	1590	1500
						RPM	680	722	752	781	807	833	867	912	936	973
						Watts	799	787	784	760	753	749	730	699	693	652
5.0	Low	1750 / 2250	11x9 3/4 2 Speed	Low	CFM	2044	2017	1983	1941	1892	1836	1773	1702	1623	1537	
					RPM	689	723	756	798	822	855	889	924	951	988	
					Watts	886	870	865	849	831	817	799	782	755	726	
	High				High	CFM	2693	2654	2606	2549	2483	2408	2323	2230	2127	2015
						RPM	876	897	915	938	956	975	996	1009	1025	1044
						Watts	1438	1427	1399	1368	1340	1312	1274	1228	1192	1146
<b>RQNJ-A060/B060</b>																
5.0	Low	1750 / 2250	11x9 1 2 Speed	Low	CFM	1953	1916	1880	1846	1812	1779	1747	1714	1681	1647	
					RPM	681	720	757	792	823	855	889	922	955	994	
					Watts	432	455	485	496	518	540	554	571	582	605	
	High				High	CFM	2201	2168	2134	2101	2067	2035	2004	1975	1947	1922
						RPM	754	782	806	838	881	907	936	960	996	1032
						Watts	627	641	668	682	718	739	754	770	792	820

# INDOOR AIR-FLOW PERFORMANCE FOR 2.0-5.0 TON PACKAGE HEAT PUMPS

Nominal Cooling Capacity Tons	Motor Speed From Factory	Manufacturer Recommended Air-Flow Range (Min / Max) CFM	Blower Size/ Motor HP # of Speeds	Motor Speed	CFM Air Delivery/RPM/Watts-208 Volts											
					External Static Pressure-Inches W.C.											
					0.10	0.20	0.30	0.40	0.50	0.60	0.70	0.80	0.90	1.00		
2.0	Low	700 / 900	10x9 1/4 2 Speed	Low	CFM	723	692	654	609	556	496	428				
					RPM	443	528	651	710	819	863	914				
					Watts	230	222	219	214	202	196	184				
2.5	Low	875 / 1125	10x9 1/3 2 Speed	Low	CFM	1062	1062	1058	1043	1013	962	884	774	627	437	
					RPM	528	618	674	735	812	895	936	985	1055	1080	
					Watts	396	393	384	376	361	335	318	297	244	223	
3.0	Low	1050 / 1350	10x9 1/2 2 Speed	Low	CFM	923	904	874	832	774	698	602	483			
					RPM	498	543	648	728	806	853	947	989			
					Watts	280	278	268	259	252	243	219	201			
3.5	Low	1225 / 1575	11x9 1/2 2 Speed	Low	CFM	1164	1154	1143	1124	1090	1034	948	826	660	445	
					RPM	526	596	670	744	803	864	945	971	1051	1078	
					Watts	401	398	388	379	371	350	322	310	259	235	
4.0	Low	1400 / 1800	11x9 3/4 2 Speed	Low	CFM	1145	1142	1118	1073	1006	918					
					RPM	556	645	703	769	828	909					
					Watts	346	340	335	326	321	298					
5.0	Low	1750 / 2250	11x9 3/4 2 Speed	Low	CFM	1884	1850	1815	1772	1712	1630	1516	1363	1164	910	
					RPM	791	834	871	912	946	975	1004	1032	1083	1097	
					Watts	704	694	675	655	638	606	581	548	464	440	
5.0	Low	1750 / 2250	11x9 3/4 2 Speed	High	CFM	1279	1237	1196	1151	1098	1032	950	846	717.13	557.65	
					RPM	490	539	598	653	709	772	811	887	928	978	
					Watts	401	400	393	391	381	373	364	343	329	303	
5.0	Low	1750 / 2250	11x9 3/4 2 Speed	High	CFM	1751	1729	1698	1658	1608	1549	1481	1404	1317	1221	
					RPM	640	668	706	734	781	813	851	888	937	968	
					Watts	660	658	651	644	628	617	603	581	557	524	
5.0	Low	1750 / 2250	11x9 3/4 2 Speed	High	CFM	1400	1393	1373	1337	1288	1225	1147	1055	949	828.48	
					RPM	536	578	623	677	718	782	830	863	902	976	
					Watts	471	466	458	455	453	442	429	420	403	374	
5.0	Low	1750 / 2250	11x9 3/4 2 Speed	High	CFM	1786	1764	1734	1695	1649	1595	1532	1462	1384	1297	
					RPM	618	643	684	726	757	805	841	883	924	955	
					Watts	665	660	651	646	638	626	612	596	573	555	
5.0	Low	1750 / 2250	11x9 3/4 2 Speed	High	CFM	1848	1821	1785	1742	1690	1630	1562	1486	1402	1309	
					RPM	660	685	722	755	795	836	867	904	940	975	
					Watts	731	725	720	707	698	680	665	651	623	596	
5.0	Low	1750 / 2250	11x9 3/4 2 Speed	High	CFM	2444	2420	2384	2337	2278	2208	2127	2034	1930	1814	
					RPM	829	838	863	885	914	936	958	983	1003	1029	
					Watts	1225	1218	1197	1191	1160	1135	1105	1068	1035	980	

## RQNJ-A060/B060

5.0	Low	1750 / 2250	11x9 3/4 2 Speed	Low	CFM	1953	1916	1880	1846	1812	1779	1747	1714	1681	1647
					RPM	681	720	757	792	823	855	889	922	955	994
					Watts	432	455	485	496	518	540	554	571	582	605
5.0	Low	1750 / 2250	11x9 3/4 2 Speed	High	CFM	2201	2168	2134	2101	2067	2035	2004	1975	1947	1922
					RPM	754	782	806	838	881	907	936	960	996	1032
					Watts	627	641	668	682	718	739	754	770	792	820

# ELECTRIC HEATER KIT - 1 PHASE

<b>208-240 VOLT, SINGLE PHASE, 60 HZ, AUXILIARY ELECTRIC HEATER KITS CHARACTERISTICS AND APPLICATION</b>														
Model No. RQNJ-	RXQJ-Heater Kit Nominal kW	No. of Elements	No. of Sequence Steps	Rated Heater kW @ 208-240 V	Heater KBTU/Hr @ 208-240 V	Heater Amp. @ 208 V	Unit Min. Ckt Ampacity @ 208-240 V	Over Current Protective Device Size		Separate Power Supply For Both Unit And Heater Kit				
								Min/Max @ 208 V	Min/Max @ 240 V	Heater Kit Min. Ckt. Ampacity	Heater Kit Max. Fuse Size	Heat Pump Min. Ckt. Ampacity 208	Heat Pump Current Protective Device Size Min/Max @ 208 V	Heat Pump Current Protective Device Size 240 V
A024J	No Heat	-	-	-	-	-	17/17	20/25	20/25	-	-	17/17	20/25	20/25
	C05J	1	1	3.6/4.8	12.28/16.38	17.33/20	39/42	40/40	45/45	22/25	25/25	-	-	-
	C07J	1	1	5.4/7.2	18.42/24.56	26/30	50/55	50/50	60/60	33/38	35/40	-	-	-
	C10J	2	1	7.2/9.6	24.57/32.76	34.7/40	60/67	60/60	70/70	44/50	45/50	-	-	-
A030J	No Heat	-	-	-	-	-	19/19	25/30	25/30	-	-	19/19	25/30	25/30
	C05J	1	1	3.6/4.8	12.28/16.38	17.33/20	41/44	45/45	45/50	22/25	25/25	-	-	-
	C07J	1	1	5.4/7.2	18.42/24.56	26/30	51/56	60/60	60/60	33/38	35/40	-	-	-
	C10J	2	1	7.2/9.6	24.57/32.76	34.7/40	62/69	70/70	70/70	44/50	45/50	-	-	-
A036J	No Heat	-	-	-	-	-	84/94	90/90	100/100	65/75	70/80	-	-	-
	C05J	1	1	3.6/4.8	12.28/16.38	17.33/20	23/23	30/35	30/35	22/25	25/25	23/23	30/35	30/35
	C07J	1	1	5.4/7.2	18.42/24.56	26/30	45/48	50/50	50/50	33/38	35/40	-	-	-
	C10J	2	1	7.2/9.6	24.57/32.76	34.7/40	66/73	70/70	80/80	44/50	45/50	-	-	-
A042J	No Heat	-	-	-	-	-	88/98	90/90	100/100	65/75	70/80	-	-	-
	C05J	1	1	3.6/4.8	12.28/16.38	17.33/20	110/123	110/110	125/125	87/100	90/100	-	-	-
	C07J	1	1	5.4/7.2	18.42/24.56	26/30	26/26	30/40	30/40	22/25	25/25	26/26	30/40	30/40
	C10J	2	1	7.2/9.6	24.57/32.76	34.7/40	58/63	60/60	70/70	33/38	35/40	-	-	-
A048J	No Heat	-	-	-	-	-	69/76	70/70	80/80	44/50	45/50	-	-	-
	C05J	1	1	3.6/4.8	12.28/16.38	17.33/20	91/101	100/100	110/110	65/75	70/80	-	-	-
	C07J	1	1	5.4/7.2	18.42/24.56	26/30	112/126	125/125	150/150	87/100	90/100	-	-	-
	C10J	2	1	7.2/9.6	24.57/32.76	34.7/40	28/28	35/45	35/45	22/25	25/25	28/28	35/45	35/45
A060J	No Heat	-	-	-	-	-	50/53	60/60	60/60	22/25	25/25	-	-	-
	C05J	1	1	3.6/4.8	12.28/16.38	17.33/20	61/66	70/70	70/70	33/38	35/40	-	-	-
	C07J	1	1	5.4/7.2	18.42/24.56	26/30	72/78	80/80	80/80	44/50	45/50	-	-	-
	C10J	2	1	7.2/9.6	24.57/32.76	34.7/40	93/103	100/100	110/110	65/75	70/80	-	-	-
B060J	No Heat	-	-	-	-	-	115/128	125/125	150/150	87/100	90/100	-	-	-
	C05J	1	1	3.6/4.8	12.28/16.38	17.33/20	41/41	50/60	50/60	22/25	25/25	41/41	50/60	50/60
	C07J	1	1	5.4/7.2	18.42/24.56	26/30	62/66	80/80	80/80	33/38	35/40	-	-	-
	C10J	2	1	7.2/9.6	24.57/32.76	34.7/40	73/78	90/90	90/90	44/50	45/50	-	-	-

# ELECTRIC HEATER KIT - 3 PHASE

<b>208-240 VOLT, THREE PHASE, 60 HZ, AUXILIARY ELECTRIC HEATER KITS CHARACTERISTICS AND APPLICATION</b>															
Model No. RQNJ-	RXQJ-Heater Kit Nominal kW	No. of Elements	No. of Sequence Steps	Rated Heater kW @ 208-240 V	Heater KBTU/Hr @ 208-240 V	Heater Amp. @ 208 V	Unit Min. Ckt Ampacity @ 208-240 V	Over Current Protective Device Size			Heater Kit			Heat Pump	
								Min/Max @ 208 V	Min/Max @ 240 V	Min. Ckt. Ampacity	Max. Fuse Size	Min. Ckt. Ampacity 208	Min. Ckt. Ampacity 240	Min/Max @ 208 V	Min/Max @ 240 V
<b>Single Power Supply For Both Unit And Heater Kit</b>							<b>Separate Power Supply For Both Unit And Heater Kit</b>								
A036C	No Heat	-	-	-	-	-	17/17	20/25	20/25	-	-	-	17/17	20/25	20/25
	C10C	2	1	7.2/9.6	24.57/32.76	20/23.1	42/46	45/45	50/50	25/29	25/30	-	-	-	-
	C15C	3	2	10.8/14.4	36.85/49.13	30/34.6	55/60	60/60	60/60	38/44	40/45	-	-	-	-
A042C	No Heat	-	-	-	-	-	19/19	25/30	25/30	-	-	-	19/19	25/30	25/30
	C10C	2	1	7.2/9.6	24.57/32.76	20/23.1	44/48	45/50	50/50	25/29	25/30	-	-	-	-
	C15C	3	2	10.8/14.4	36.85/49.13	30/34.6	57/63	60/60	70/70	38/44	40/45	-	-	-	-
	C20C	4	2	14.4/19.2	49.12/65.52	40/46.2	69/77	70/70	80/80	50/58	50/60	-	-	-	-
A048C	No Heat	-	-	-	-	-	22/22	25/30	25/30	-	-	-	22/22	25/30	25/30
	C10C	2	1	7.2/9.6	24.57/32.76	20/23.1	47/50	50/50	50/50	25/29	25/30	-	-	-	-
	C15C	3	2	10.8/14.4	36.85/49.13	30/34.6	59/65	60/60	70/70	38/44	40/45	-	-	-	-
	C20C	4	2	14.4/19.2	49.12/65.52	40/46.2	72/79	80/80	80/80	50/58	50/60	-	-	-	-
A060C	No Heat	-	-	-	-	-	31/31	35/45	35/45	-	-	-	31/31	35/45	35/45
	C10C	2	1	7.2/9.6	24.57/32.76	20/23.1	56/60	60/60	70/70	25/29	25/30	-	-	-	-
	C15C	3	2	10.8/14.4	36.85/49.13	30/34.6	68/74	70/70	80/80	38/44	40/45	-	-	-	-
	C20C	4	2	14.4/19.2	49.12/65.52	40/46.2	81/89	90/90	90/90	50/58	50/60	-	-	-	-
B060C	No Heat	-	-	-	-	-	32/32	35/45	35/45	-	-	-	32/32	35/45	35/45
	C10C	2	1	7.2/9.6	24.57/32.76	20/23.1	57/60	60/60	70/70	25/29	25/30	-	-	-	-
	C15C	3	2	10.8/14.4	36.85/49.13	30/34.6	69/75	70/70	80/80	38/44	40/45	-	-	-	-
	C20C	4	2	14.4/19.2	49.12/65.52	40/46.2	82/89	90/90	90/90	50/58	50/60	-	-	-	-

**FIGURE 7**  
**WIRING DIAGRAM**

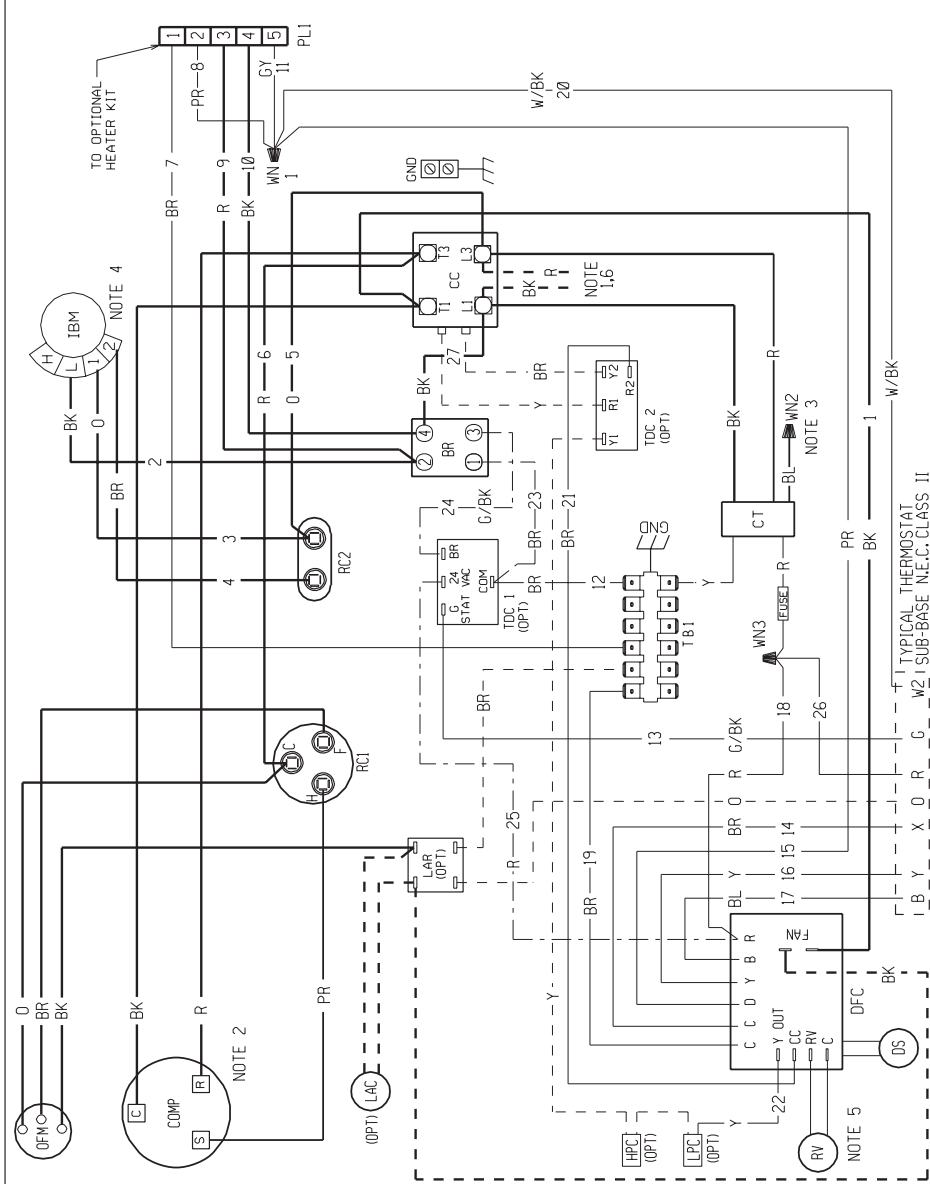
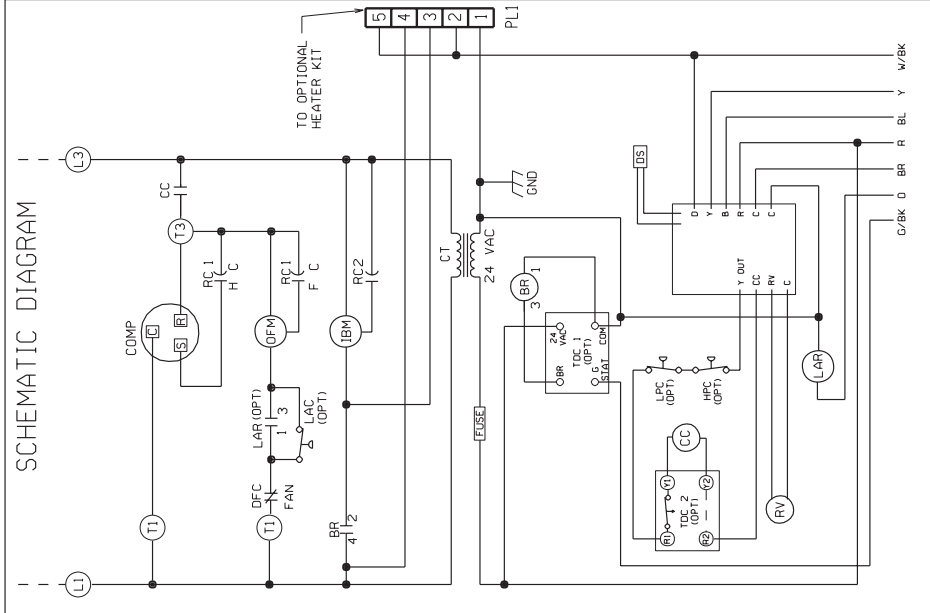

COMPONENT CODE	WIRING INFORMATION	WIRE COLOR CODE
ALC	AUX. LIMIT CONTROL	BK ___ BLACK
BR	BLOWER RELAY	BR ___ BROWN
CC	COMPRESSOR CONTACTOR	BL ___ BLUE
CCH	CRANKCASE HEATER	R ___ RED
COMP	COMPRESSOR	G ___ GREEN
CFC	CONTROL TRANSFORMER	GY ___ GRAY
CL	CLAP	O ___ ORANGE
CR	CRANKCASE HEATER	PR ___ PURPLE
DFC	DEFROST CONTROL	Y ___ YELLOW
DS	DEFROST SENSOR	
DS	DEFROST SENSOR	
GND	GROUND	
HGS	HOT GAS SENSOR	
HPC	HIGH PRESSURE CONTROL	
IBM	INDOOR BLOWER MOTOR	
LAR	LOW AMBIENT CONTROL	
LAC	LOW AMBIENT COOLING CONTROL	
LRF	LOW AMBIENT RELAY	
OFM	OUTDOOR FAN MOTOR	
OPT	OPTIONAL	
RC	REVERSING VALVE	
RV	REVERSING VALVE	
TDC	TIME DELAY CONTROL	
WIRE NUT	WIRE NUT	
Y	YOG	
Y OUT	YOG	
Z	ZOG	

LINE VOLTAGE	REPLACEMENT WIRE
-FACTORY STANDARD	-MUST BE THE SAME SIZE AND TYPE OF INSULATION AS ORIGINAL (105 C MIN.)
-FACTORY OPTION	-REPLACEMENT WIRE
-FIELD INSTALLED	-MUST BE THE SAME SIZE AND TYPE OF INSULATION AS ORIGINAL (105 C MIN.)
LOW VOLTAGE	-REPLACEMENT WIRE
-FACTORY STANDARD	-MUST BE THE SAME SIZE AND TYPE OF INSULATION AS ORIGINAL (105 C MIN.)
-FACTORY OPTION	-REPLACEMENT WIRE
-FIELD INSTALLED	-MUST BE THE SAME SIZE AND TYPE OF INSULATION AS ORIGINAL (105 C MIN.)

CONNECTORS SUITABLE FOR USE WITH COPPER CONDUCTORS ONLY.	CONNECTOR MOTOR THERMALLY PROTECTED.
1. CONNECTORS SUITABLE FOR USE WITH COPPER CONDUCTORS ONLY.	2. CONNECTOR MOTOR THERMALLY PROTECTED.
3. TRANSFORMER FACTORY WIRED FOR 230 VOLTS. USE RED AND BLUE LEADS FOR 208 VOLTS.	4. MOTOR FACTORY WIRED FOR LOW SPEED. SEE AIRFLOW TABLES IN INSTALLATION INSTRUCTIONS TO DETERMINE CORRECT SPEED FOR UNIT APPLICATION.
5. THIS COMPONENT ENERGIZED IN HEATING.	6. FIELD WIRING OR CONNECTION FROM HEATER KIT FUSE BLOCK.

DR. BY	DATE	DWG. NO.	REV
BJL	02-10-04	90-23621-08	04

**FIGURE 8**  
**WIRING DIAGRAM**

**SCHEMATIC DIAGRAM**

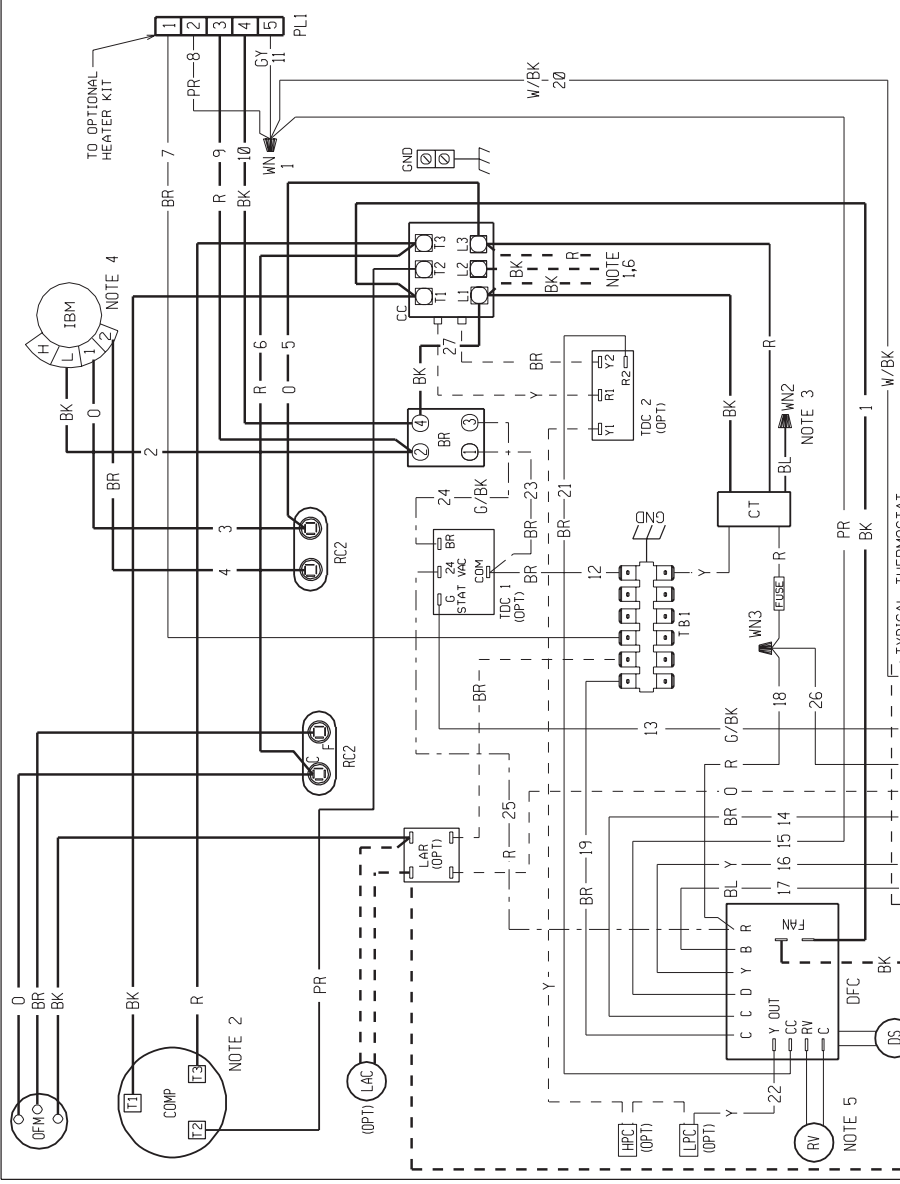
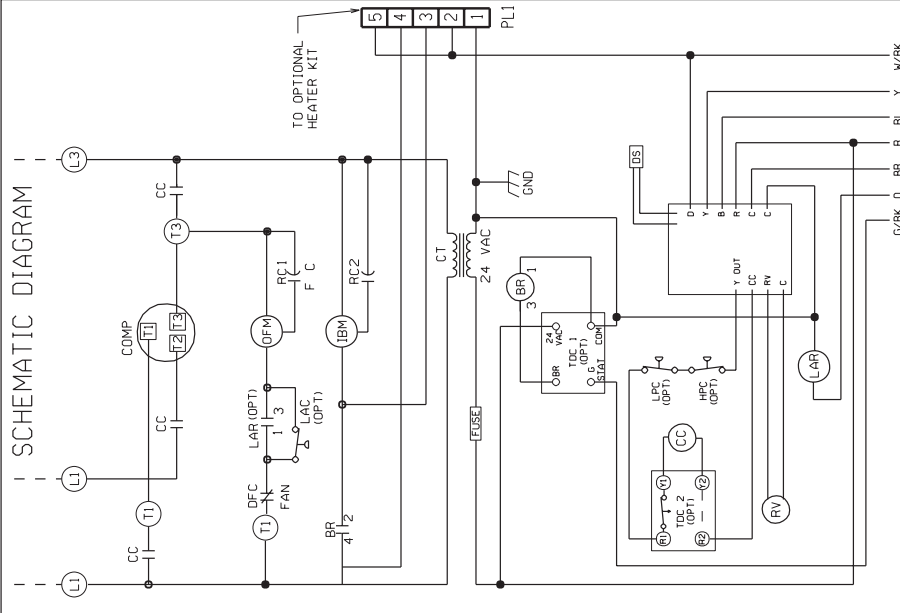

**WIRE COLOR CODE**

BK	BLACK
BR	BROWN
BL	BLUE
C	GREEN
GY	GRAY
O	ORANGE
PR	PURPLE
R	RED
W	WHITE
Y	YELLOW

**ELECTRICAL WIRING DIAGRAM**

**PACKAGE HEAT PUMP**

3 PH, 208/230 VOLT - 60 HZ

DR. BY: MCB    APP. BY: DATE: 9-29-04    DWG. NO.: 90-23621-10    REV: 01

**WIRING INFORMATION**

- LINE VOLTAGE
- FACTORY STANDARD
- FACTORY OPTION
- FIELD INSTALLED
- LOW VOLTAGE
- FACTORY STANDARD
- FACTORY OPTION
- FIELD INSTALLED
- REPLACEMENT WIRE
- MUST BE THE SAME SIZE AND TYPE OF INSULATION AS ORIGINAL (105 C MIN.)
- CABINET MUST BE PERMANENTLY GROUNDED AND CONFORM TO I.E.C., N.E.C., C.E.C. AND LOCAL CODES AS APPLICABLE.

- NOTES:**
- CONNECTORS SUITABLE FOR USE WITH COPPER CONDUCTORS ONLY.
  - COMPRESSOR MOTOR THERMALLY PROTECTED.
  - TRANSFORMER FACTORY WIRED FOR 230 VOLTS. USE RED AND BLUE LEADS FOR 208 VOLTS.
  - MOTOR FACTORY WIRED FOR LOW SPEED. SEE AIRFLOW TABLES IN INSTALLATION INSTRUCTIONS TO DETERMINE CORRECT SPEED FOR UNIT APPLICATION.
  - THIS COMPONENT ENERGIZED IN HEATING.
  - FIELD WIRING OR CONNECTION FROM HEATER KIT FUSE BLOCK.

**COMPONENT CODE**

AUX. LIMIT CONTROL	LAC
BLOWER RELAY	LAR
COMPRESSOR CONTACTOR	OFM
CRANKCASE HEATER	OPT
COMPRESSOR	COMP
CONTROL TRANSFORMER	TDC
DEFROST RELAY	RV
DEFROST SENSOR	DS
GROUND	GND
HOT GAS SENSOR	HGS
HIGH PRESSURE CONTROL	HPC
INDOOR BLOWER MOTOR	IBM
LOW AMBIENT COOLING CONTROL	LAC
LOW AMBIENT RELAY	LAR
OUTDOOR FAN MOTOR	OFM
OPTIONAL	OPT
RUN CAPACITOR	CC
REVERSING VALVE	RV
TERMINAL BLOCK	TB
TIME DELAY CONTROL	TDC
WIRE NUT	WN

DWG. NO.: 90-23621-10    REV: 01



**FIGURE 9**  
**WIRING DIAGRAM**

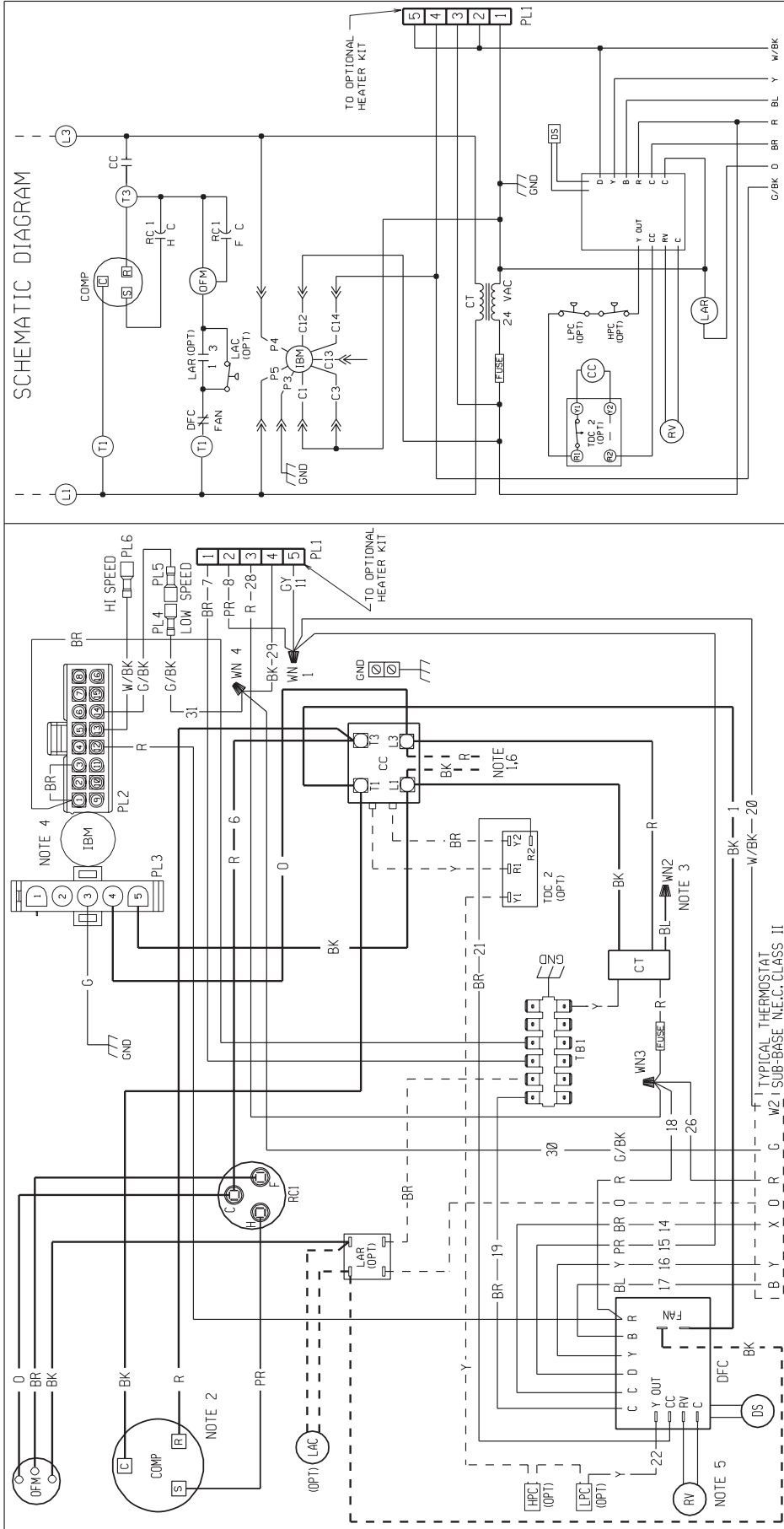

COMPONENT CODE	WIRING INFORMATION	WIRE COLOR CODE
AUX. LIMIT CONTROL	LINE VOLTAGE	BK ___ BLACK
BLOWER RELAY	-FACTORY STANDARD	BR ___ BROWN
COMPRESSOR CONTACTOR	-FACTORY OPTION	BL ___ BLUE
CRANKCASE HEATER	-FIELD INSTALLED	R ___ RED
COMPRESSOR	LOW VOLTAGE	G ___ GREEN
CONTROL TRANSFORMER	-FACTORY STANDARD	Y ___ YELLOW
CONTROL RELAY	-FACTORY OPTION	
DEFROST RELAY	-FIELD INSTALLED	
DEFROST SENSOR	REPLACEMENT WIRE	
GROUND	-MUST BE THE SAME SIZE AND TYPE OF INSULATION AS ORIGINAL (105 C MIN.)	
HOT GAS SENSOR	-CABINET MUST BE PERMANENTLY GROUNDED AND CONFORM TO I.E.C., N.E.C., C.E.C. AND LOCAL CODES AS APPLICABLE.	
HIGH PRESSURE CONTROL		
INDOOR BLOWER MOTOR		

DR. BY	DATE	APP. BY	DATE	DWG. NO.	REV
MCB	9-29-04			90-23621-09	01

**FIGURE 10**  
**WIRING DIAGRAM**

**SCHEMATIC DIAGRAM**

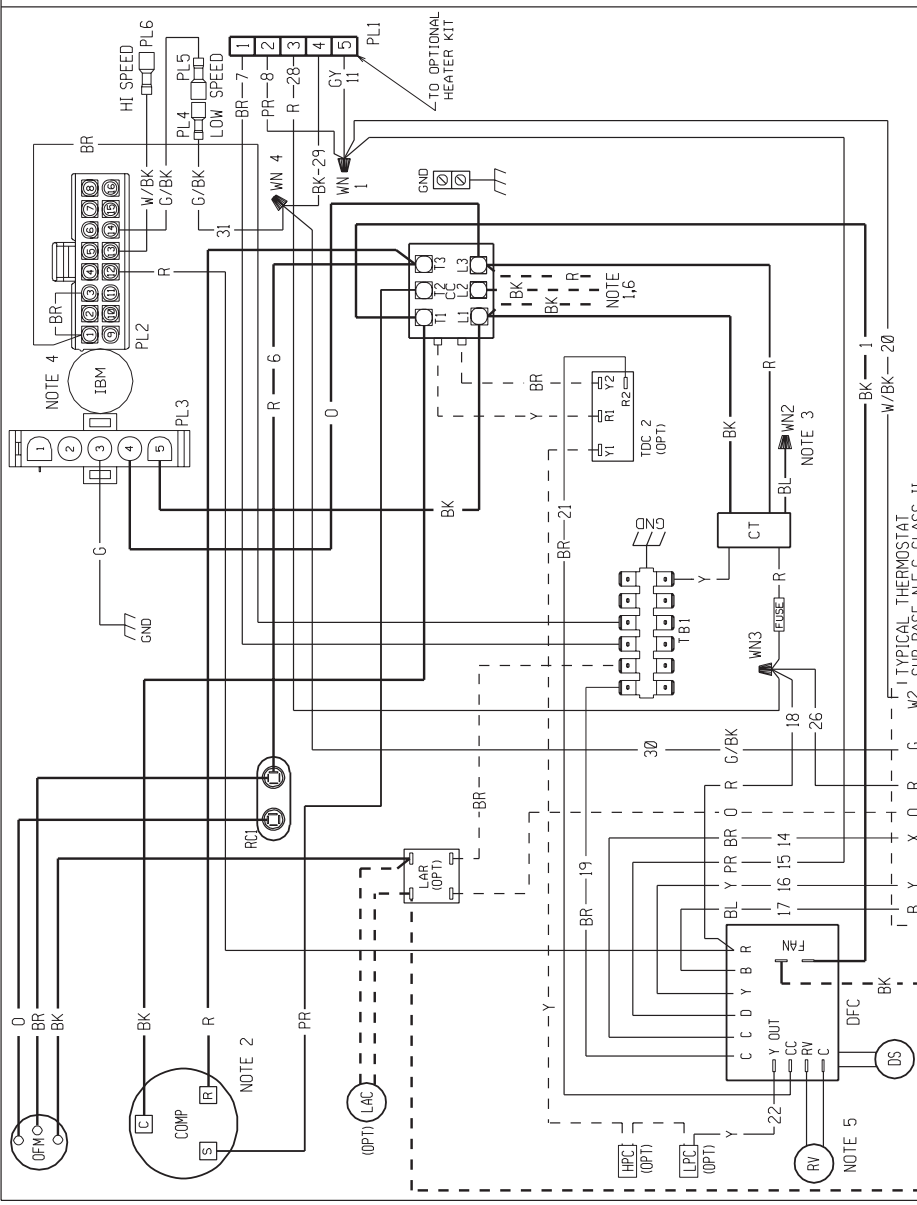
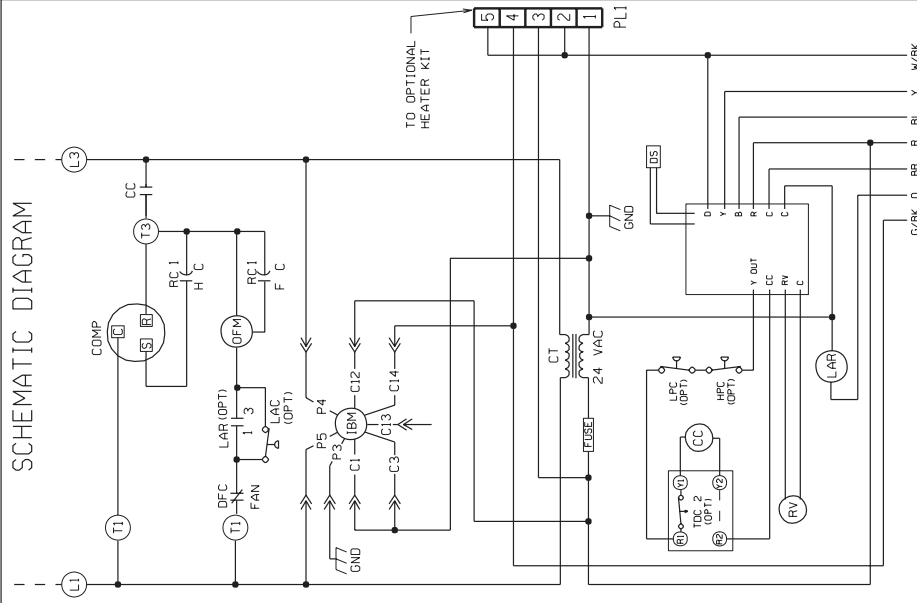

**WIRE COLOR CODE**

BK	BLACK
BR	BROWN
BL	BLUE
G	GREEN
GY	GRAY
O	ORANGE
PR	PURPLE
R	RED
W	WHITE
Y	YELLOW

**ELECTRICAL WIRING DIAGRAM**

**PACKAGE HEAT PUMP**

3 PH, 208/230 VOLT - 60 HZ

DR. BY DATE 9-29-04  
MBC

REV 01

- WIRING INFORMATION**
- LINE VOLTAGE
  - FACTORY STANDARD
  - FACTORY OPTION
  - FIELD INSTALLED
  - LOW VOLTAGE
  - FACTORY STANDARD
  - FACTORY OPTION
  - FIELD INSTALLED
  - REPLACEMENT WIRE
  - MUST BE THE SAME SIZE AND TYPE OF INSULATION AS ORIGINAL (105 C MIN.)
  - CABINET MUST BE PERMANENTLY GROUNDED AND CONFORM TO I.E.C., N.E.C., C.E.C. AND LOCAL CODES AS APPLICABLE.

- NOTES:**
- CONNECTORS SUITABLE FOR USE WITH COPPER CONDUCTORS ONLY.
  - COMPRESSOR MOTOR THERMALLY PROTECTED.
  - TRANSFORMER FACTORY WIRED FOR 230 VOLTS. USE RED AND BLUE LEADS FOR 208 VOLTS.
  - MOTOR FACTORY WIRED FOR LOW SPEED. SEE AIRFLOW TABLES IN INSTALLATION INSTRUCTIONS TO DETERMINE CORRECT SPEED FOR UNIT APPLICATION.
  - THIS COMPONENT ENERGIZED IN HEATING.
  - FIELD WIRING OR CONNECTION FROM HEATER KIT FUSE BLOCK.

**COMPONENT CODE**

ALC	AUX. LIMIT CONTROL
BR	BLOWER RELAY
CC	COMPRESSOR CONTACTOR
CCH	CRANKCASE HEATER
CCMP	COMPRESSOR
CFC	CONTROL TRANSFORMER
DFC	DEFROST CONTROL
DFR	DEFROST RELAY
DS	DEFROST SENSOR
DS	GROUND
HGS	HOT GAS SENSOR
HPC	HIGH PRESSURE CONTROL
IBM	INDOOR BLOWER MOTOR
LAC	LOW AMBIENT COOLING CONTROL
LAR	LOW AMBIENT RELAY
OFM	OUTDOOR FAN MOTOR
OPT	OPTIONAL
PL	PLUG CAPACITOR
RV	REVERSING VALVE
TB	TERMINAL BLOCK
TDC	TIME DELAY CONTROL
W	WIRE NUT

DWG. NO. 90-23621-11

REV 01

**FIGURE 11**  
**WIRING DIAGRAM**

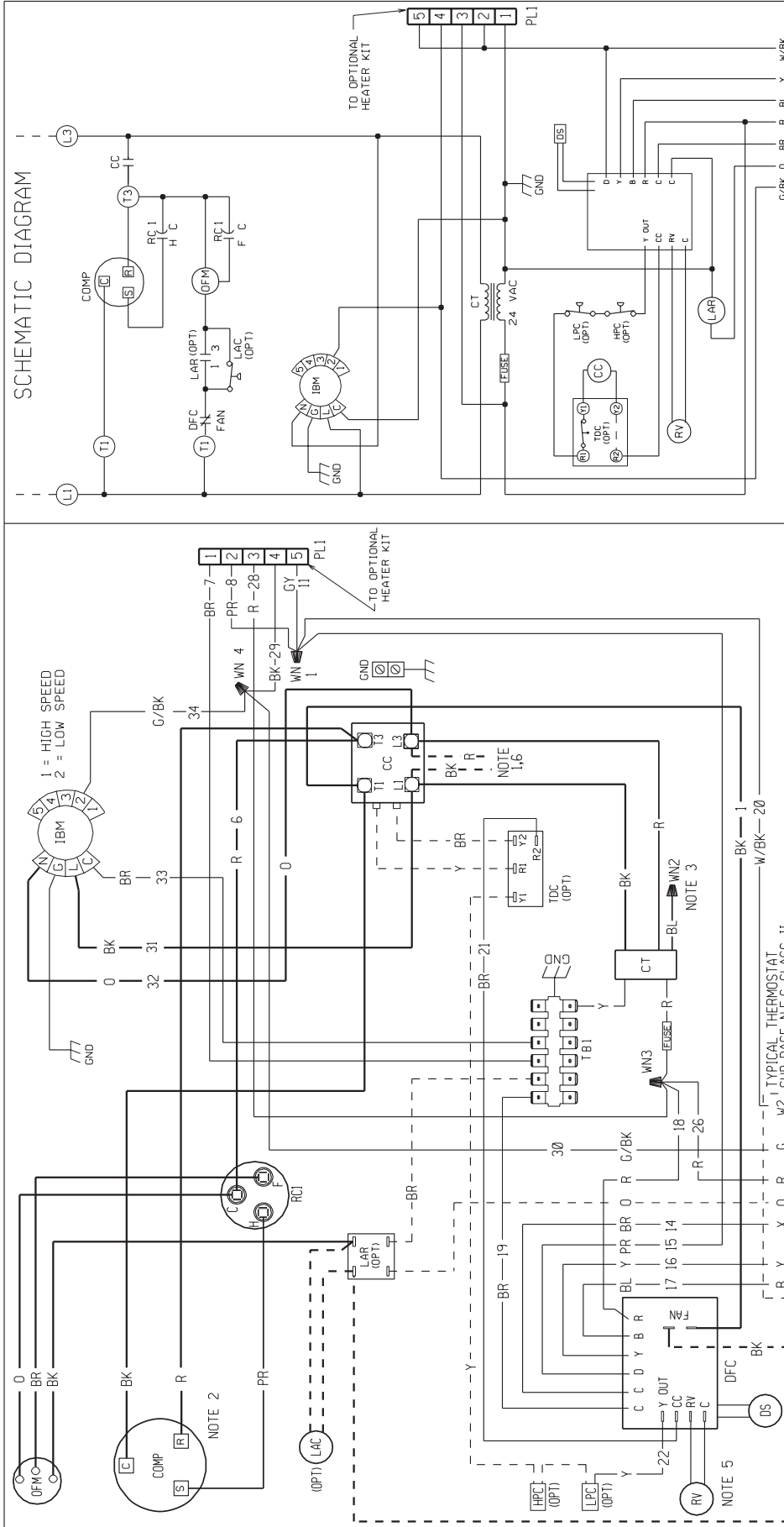

**SCHEMATIC DIAGRAM**

<p><b>COMPONENT CODE</b></p> <p>ALC AUX. LIMIT CONTROL BR BLOWER RELAY CONTACTOR CC CAPACITOR COMP COMPRESSOR CT CONTROL TRANSFORMER DFC DEFROST CONTROL DFR DEFROST RELAY DS DEFROST SENSOR GND GROUND HGS HOT GAS SENSOR HPC HIGH PRESSURE CONTROL IBM INDOOR BLOWER MOTOR</p>	<p><b>WIRING INFORMATION</b></p> <p>LINE VOLTAGE -FACTORY STANDARD -FACTORY OPTION -FIELD INSTALLED LOW VOLTAGE -FACTORY STANDARD -FACTORY OPTION -FIELD INSTALLED REPLACEMENT WIRE -MUST BE THE SAME SIZE AND TYPE OF INSULATION AS ORIGINAL (105 C° MIN.) WARNING -CABINET MUST BE PERMANENTLY GROUNDED AND CONFORM TO I.E.C., N.E.C., C.E.C. AND LOCAL CODES AS APPLICABLE.</p>	<p><b>NOTES:</b></p> <ol style="list-style-type: none"> <li>CONNECTORS SUITABLE FOR USE WITH COPPER CONDUCTORS ONLY.</li> <li>COMPRESSOR MOTOR THERMALLY PROTECTED.</li> <li>TRANSFORMER FACTORY WIRED FOR 230 VOLTS. USE RED AND BLUE LEADS FOR 208 VOLTS.</li> <li>MOTOR FACTORY WIRED FOR LOW SPEED. SEE AIRFLOW TABLES IN INSTALLATION INSTRUCTIONS TO DETERMINE CORRECT SPEED FOR UNIT APPLICATION.</li> <li>THIS COMPONENT ENERGIZED IN HEATING.</li> <li>FIELD WIRING OR CONNECTION FROM HEATER KIT FUSE BLOCK.</li> </ol>	<p><b>WIRE COLOR CODE</b></p> <p>BK---BLACK BR---BROWN BL---BLUE G---GREEN GY---GRAY O---ORANGE PR---PURPLE R---RED W---WHITE Y---YELLOW</p>
<p><b>ELECTRICAL WIRING DIAGRAM</b></p>		<p><b>PACKAGE HEAT PUMP</b></p> <p>1 PH, 208/230 VOLT - 60 HZ</p> <p>DR. BY: JRJ    APP. BY: DATE: 7-13-05    DWG. NO.: 90-23621-16    REV: 00</p>	

**FIGURE 12  
WIRING DIAGRAM**

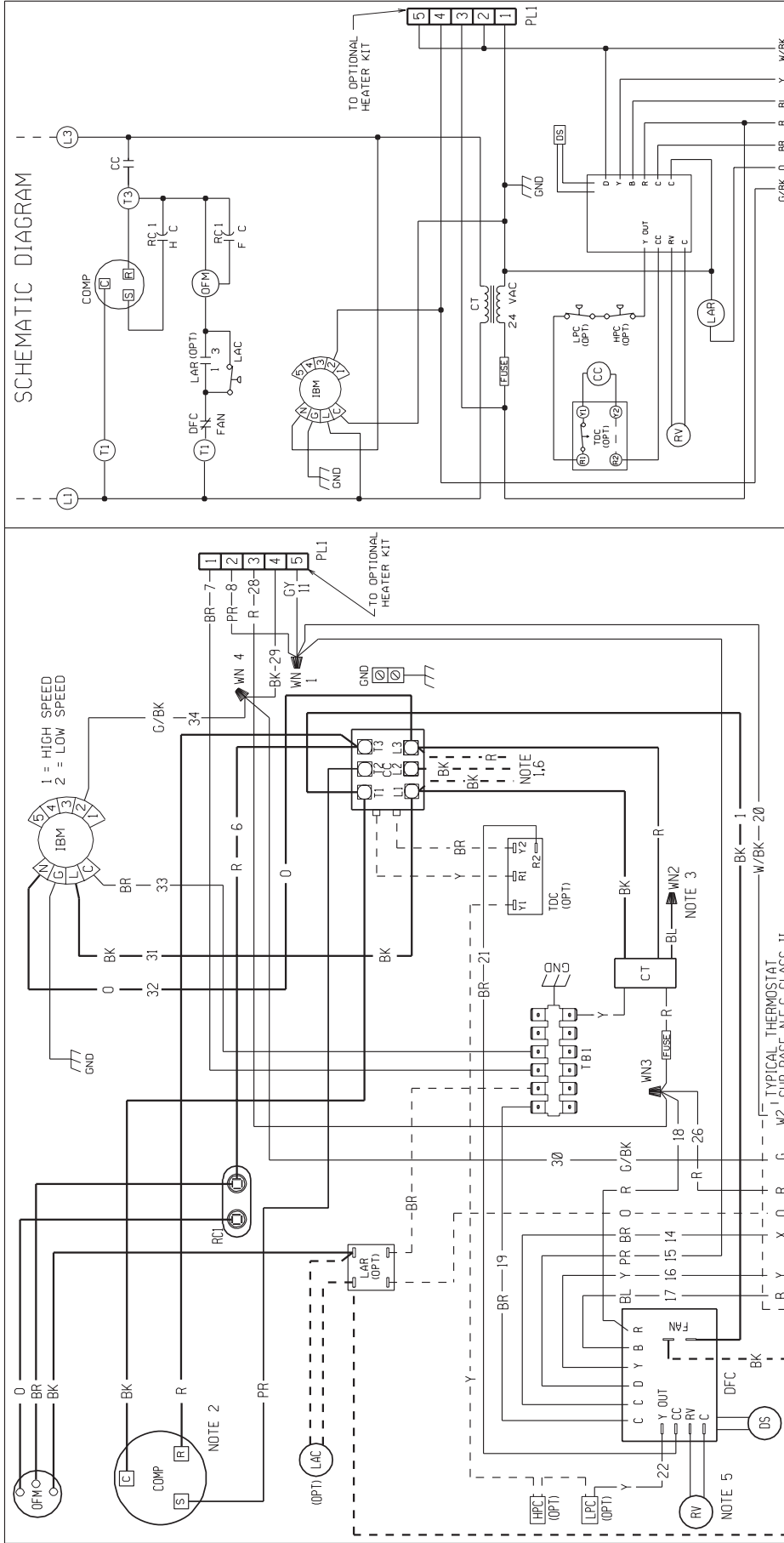

**SCHEMATIC DIAGRAM**

### WIRING INFORMATION

**LINE VOLTAGE**  
 -FACTORY STANDARD  
 -FACTORY OPTION  
 -FIELD INSTALLED

**LOW VOLTAGE**  
 -FACTORY STANDARD  
 -FACTORY OPTION  
 -FIELD INSTALLED

REPLACEMENT WIRE  
 -MUST BE THE SAME SIZE AND TYPE OF INSULATION AS ORIGINAL (105 C \*MIN)

WARNING  
 -CABINET MUST BE PERMANENTLY GROUNDED AND CONFORM TO I.E.C., N.E.C., C.E.C. AND LOCAL CODES AS APPLICABLE.

### WIRE COLOR CODE

BK --- BLACK  
 BR --- BROWN  
 BL --- BLUE  
 G --- GREEN  
 GY --- GRAY  
 O --- ORANGE  
 PR --- PURPLE  
 R --- RED  
 W --- WHITE  
 Y --- YELLOW

---

<b>COMPONENT CODE</b>	<b>NOTES:</b>
<p>LAC LOW AMBIENT COOLING CONTROL</p> <p>LAR LOW AMBIENT RELAY</p> <p>OFM OUTDOOR FAN MOTOR</p> <p>PL OPT PLUG</p> <p>CT CONTROL TRANSFORMER</p> <p>DFC DEFROST CONTROL</p> <p>DR DEFROST RELAY</p> <p>DS DEFROST SENSOR</p> <p>PT PRESSURE SWITCH</p> <p>Y WIRE NUT</p> <p>ALC AUX LIMIT CONTROL</p> <p>BR BLOWER RELAY</p> <p>CC COMPRESSOR CONTACTOR</p> <p>CC CH CRANKCASE HEATER</p> <p>COMP COMPRESSOR</p> <p>DFC DEFROST CONTROL</p> <p>DR DEFROST RELAY</p> <p>DS DEFROST SENSOR</p> <p>GND GROUND</p> <p>HGS HOT GAS SENSOR</p> <p>HPS HIGH PRESSURE SWITCH</p> <p>IBM INDOOR BLOWER MOTOR</p>	<ol style="list-style-type: none"> <li>1. CONNECTORS SUITABLE FOR USE WITH COPPER CONDUCTORS ONLY.</li> <li>2. COMPRESSOR MOTOR THERMALLY PROTECTED.</li> <li>3. TRANSFORMER FACTORY WIRE FOR 230 VOLTS. USE RED AND BLUE LEADS FOR 208 VOLTS.</li> <li>4. MOTOR FACTORY WIRE FOR LOW SPEED. SEE AIRFLOW TABLES IN INSTALLATION INSTRUCTIONS TO DETERMINE CORRECT SPEED FOR UNIT APPLICATION.</li> <li>5. THIS COMPONENT ENERGIZED IN HEATING.</li> <li>6. FIELD WIRING OR CONNECTION FROM HEATER KIT FUSE BLOCK.</li> </ol>

---

<b>PACKAGE HEAT PUMP</b>	3 PH, 208/230 VOLT - 60 HZ
	DR. BY APP. BY DATE DRWG. NO. REV
	JRJ 7-13-05 90-23621-17 00

**FIGURE 13**  
**2 TON HEAT PUMP RQNJ CHARGING CHART**

# 2.0 TON HP

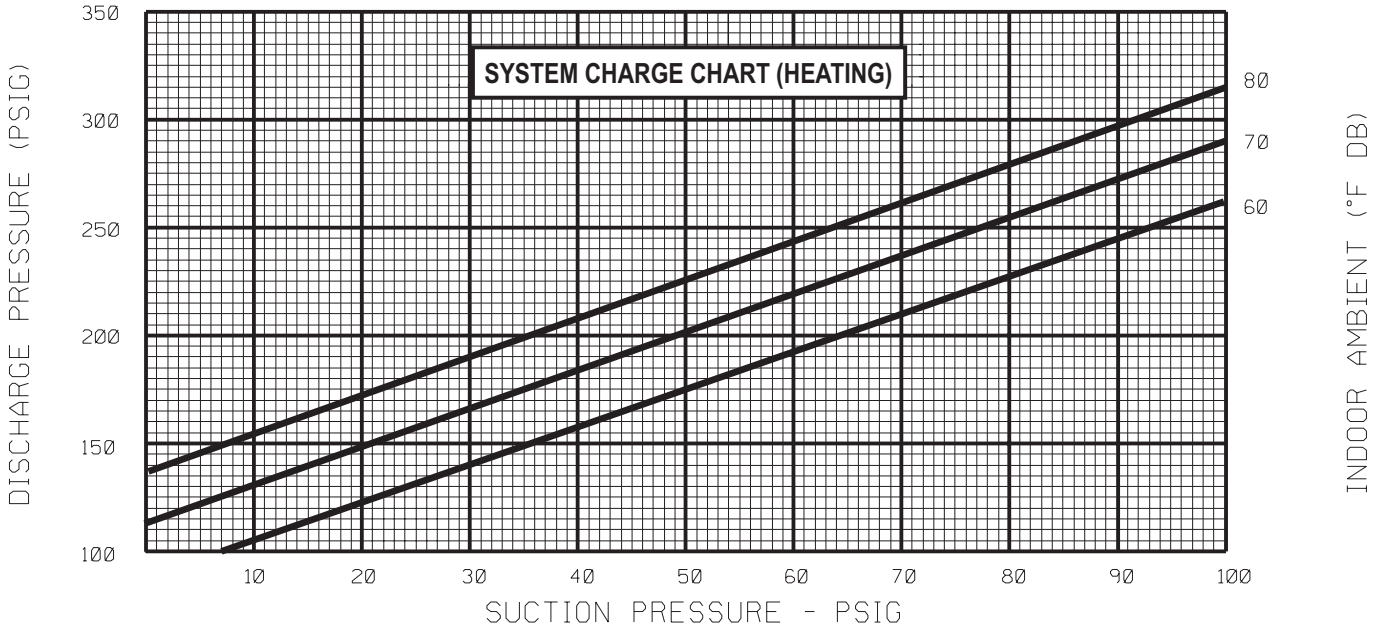
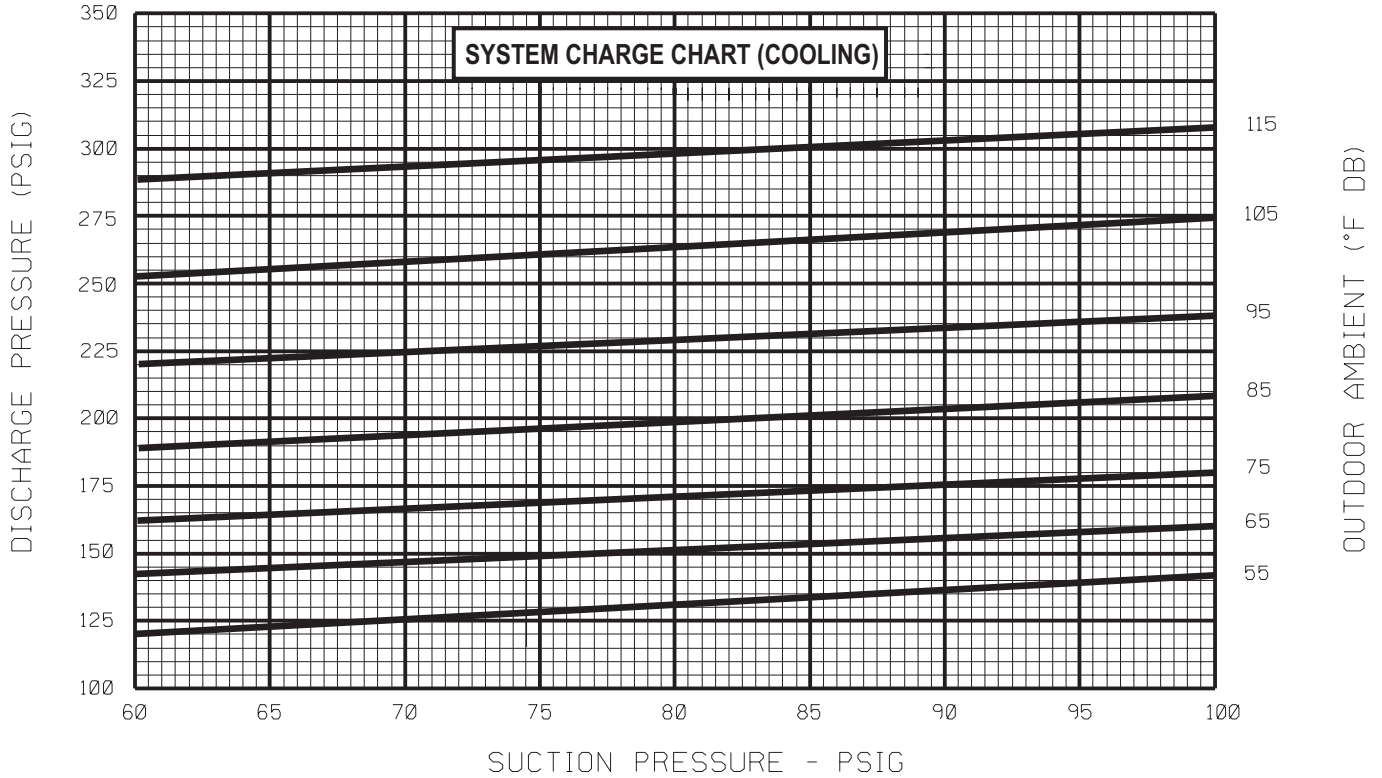

**CAUTION:** BEFORE FINAL REFRIGERANT CHECK, INDOOR RETURN AIR TEMPERATURE MUST BE BETWEEN 72°F & 76°F DB AT 50% R.H. (HEATING AND COOLING), AND NO ICE ON OUTDOOR COILS (HEATING).

**INSTRUCTIONS:**

1. CONNECT PRESSURE GAUGES TO SUCTION AND DISCHARGE PORTS ON UNIT.
2. MEASURE AIR TEMPERATURE TO: (a) OUTDOOR COIL FOR COOLING, (b) INDOOR COIL FOR HEATING.
3. PLACE AN "X" ON THE APPROPRIATE CHART WHERE THE SUCTION AND DISCHARGE PRESSURES CROSS.
4. IF "X" IS BELOW AMBIENT TEMPERATURE LINE, ADD CHARGE AND REPEAT STEP 3.
5. IF "X" IS ABOVE AMBIENT TEMPERATURE LINE, RECOVER EXCESS CHARGE AND REPEAT STEP 3.

**FIGURE 14**  
**2.5 TON HEAT PUMP RQNJ CHARGING CHART**

# 2.5 TON HP

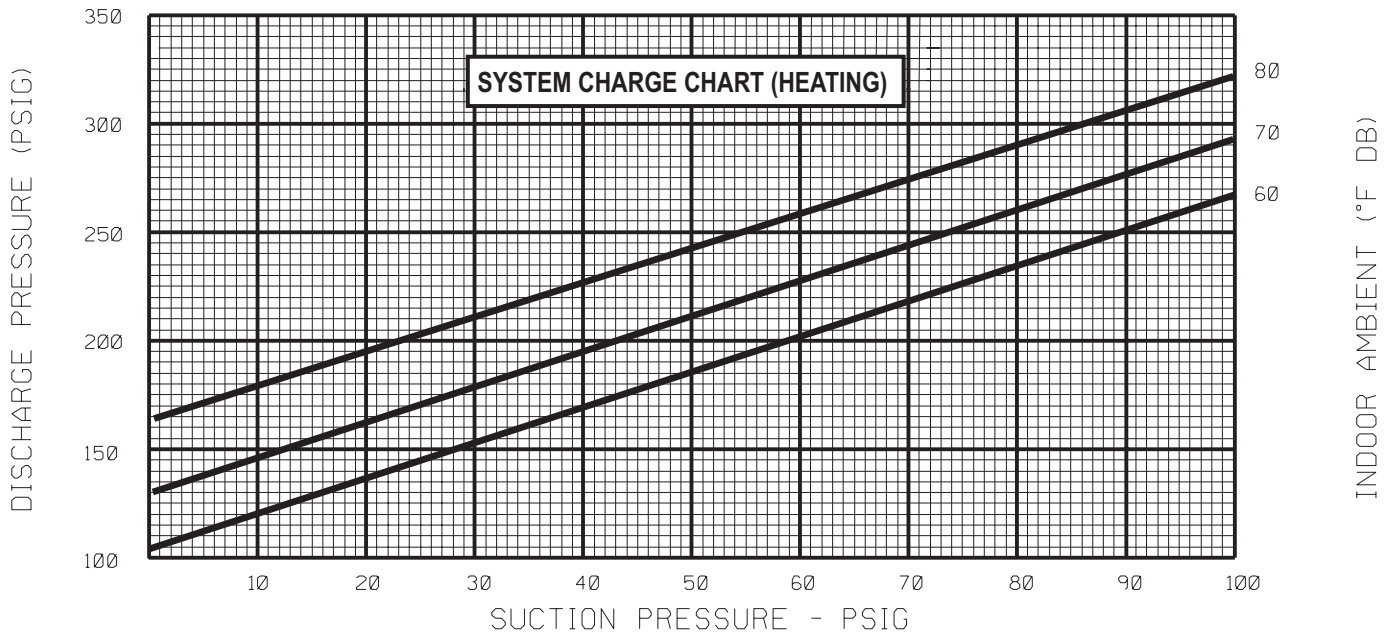
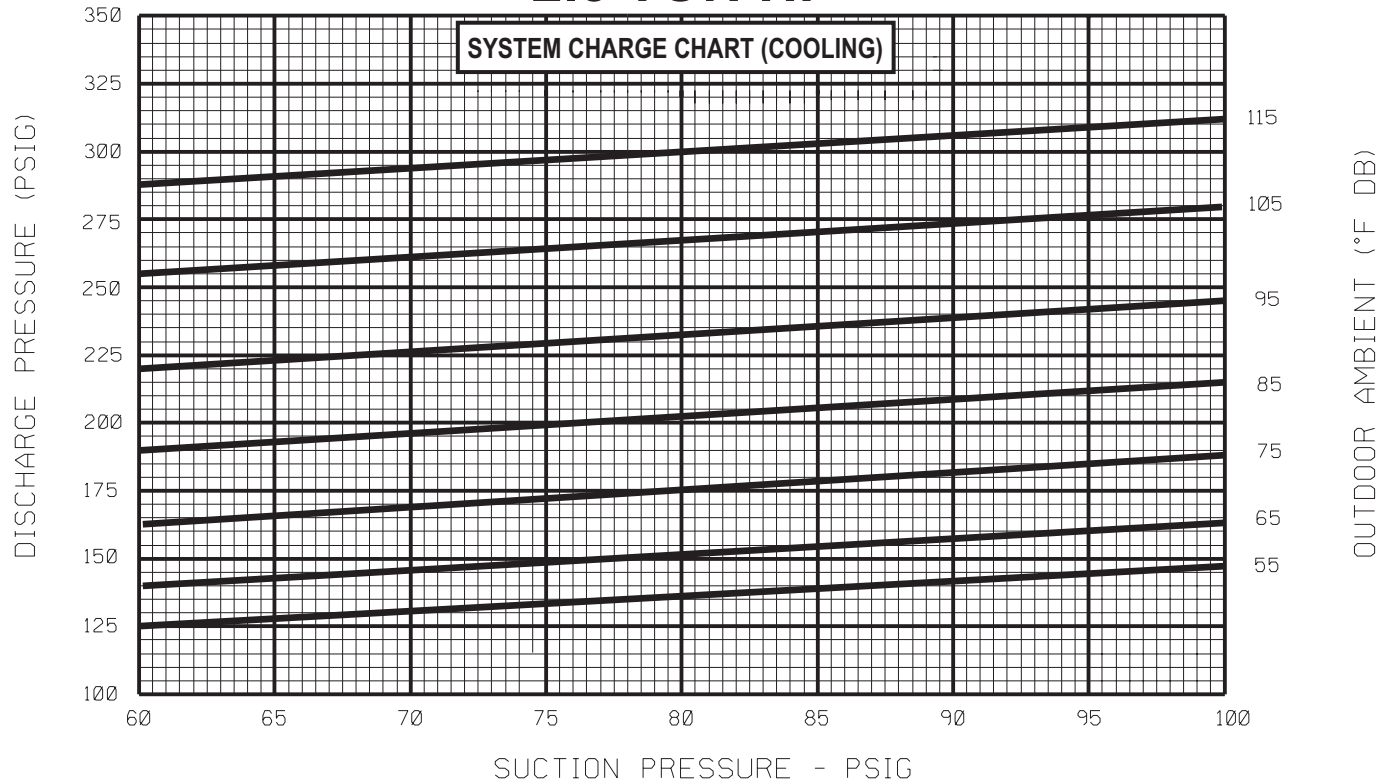

**CAUTION:** BEFORE FINAL REFRIGERANT CHECK, INDOOR RETURN AIR TEMPERATURE MUST BE BETWEEN 72°F & 76°F DB AT 50% R.H. (HEATING AND COOLING), AND NO ICE ON OUTDOOR COILS (HEATING).

**INSTRUCTIONS:**

1. CONNECT PRESSURE GAUGES TO SUCTION AND DISCHARGE PORTS ON UNIT.
2. MEASURE AIR TEMPERATURE TO: (a) OUTDOOR COIL FOR COOLING, (b) INDOOR COIL FOR HEATING.
3. PLACE AN "X" ON THE APPROPRIATE CHART WHERE THE SUCTION AND DISCHARGE PRESSURES CROSS.
4. IF "X" IS BELOW AMBIENT TEMPERATURE LINE, ADD CHARGE AND REPEAT STEP 3.
5. IF "X" IS ABOVE AMBIENT TEMPERATURE LINE, RECOVER EXCESS CHARGE AND REPEAT STEP 3.

**FIGURE 15**  
**3.0 TON HEAT PUMP RQNJ CHARGING CHART**

# 3.0 TON HP

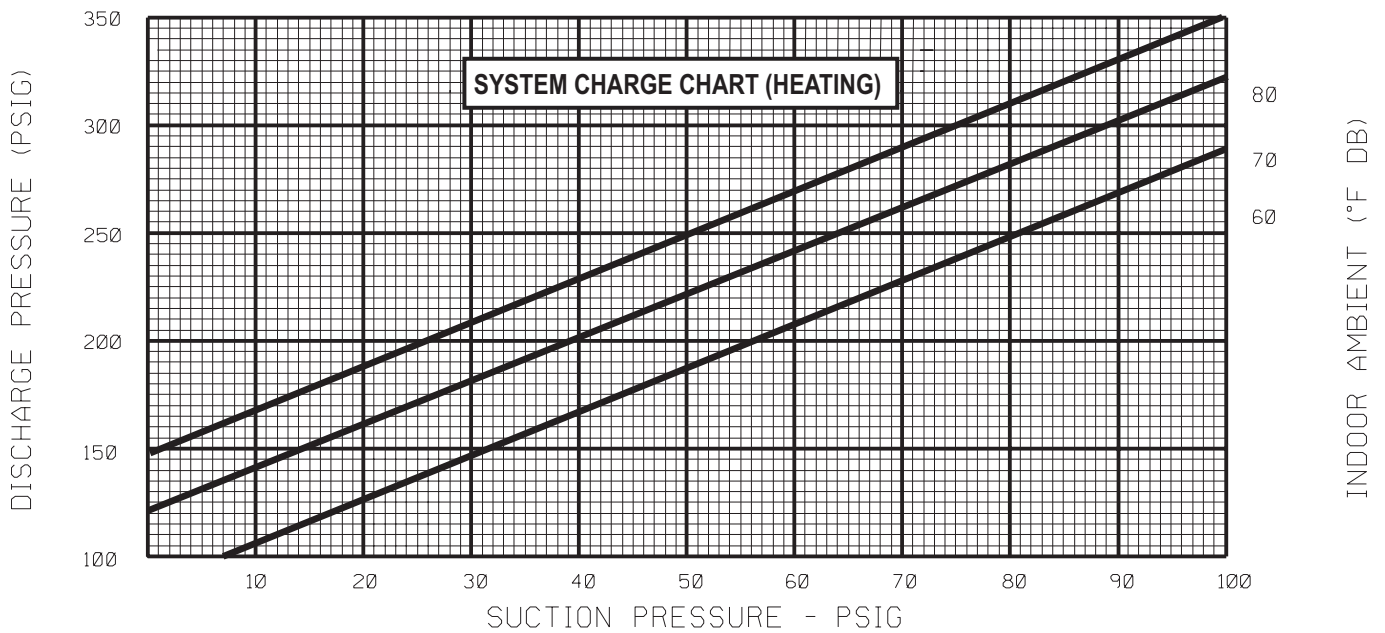
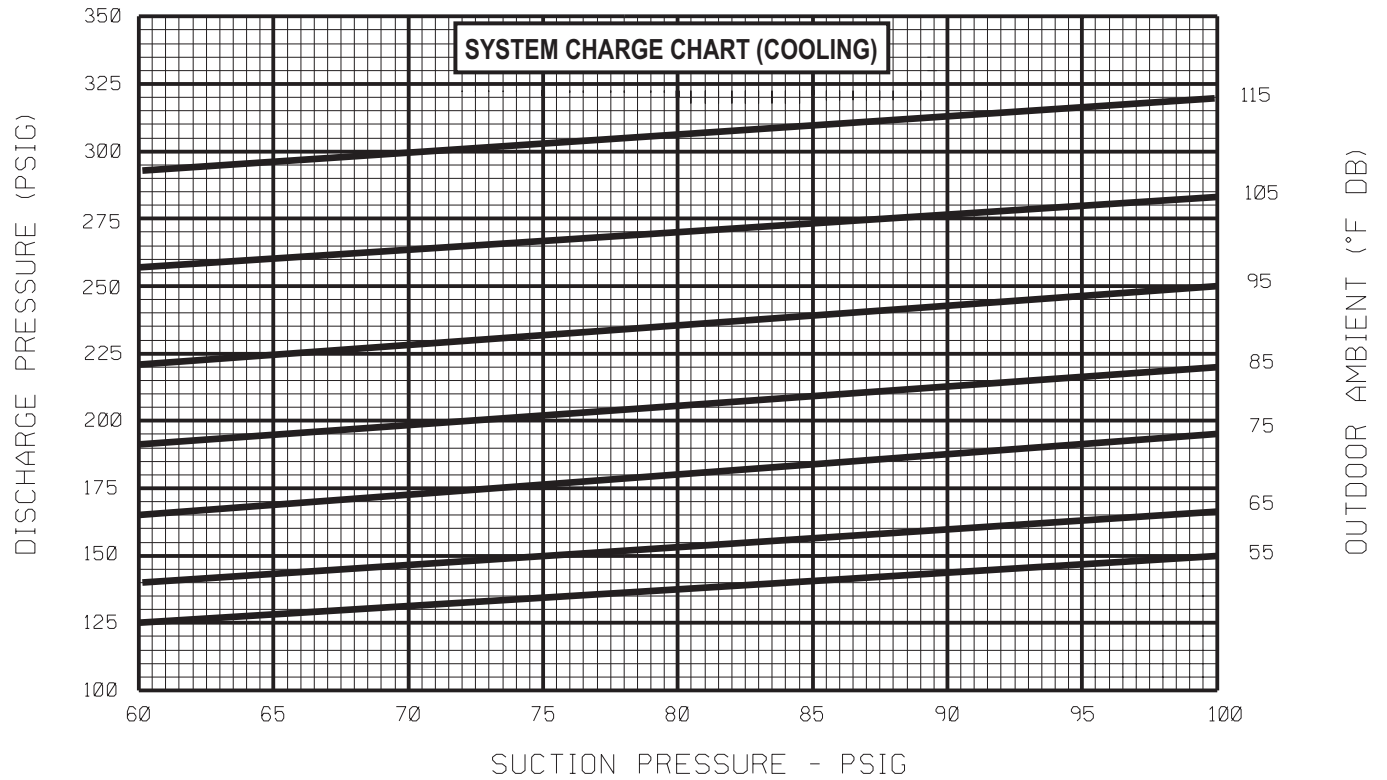

**CAUTION:** BEFORE FINAL REFRIGERANT CHECK, INDOOR RETURN AIR TEMPERATURE MUST BE BETWEEN 72°F & 76°F DB AT 50% R.H. (HEATING AND COOLING), AND NO ICE ON OUTDOOR COILS (HEATING).

**INSTRUCTIONS:**

1. CONNECT PRESSURE GAUGES TO SUCTION AND DISCHARGE PORTS ON UNIT.
2. MEASURE AIR TEMPERATURE TO: (a) OUTDOOR COIL FOR COOLING, (b) INDOOR COIL FOR HEATING.
3. PLACE AN "X" ON THE APPROPRIATE CHART WHERE THE SUCTION AND DISCHARGE PRESSURES CROSS.
4. IF "X" IS BELOW AMBIENT TEMPERATURE LINE, ADD CHARGE AND REPEAT STEP 3.
5. IF "X" IS ABOVE AMBIENT TEMPERATURE LINE, RECOVER EXCESS CHARGE AND REPEAT STEP 3.

**FIGURE 16**  
**3.5 TON HEAT PUMP RQNJ CHARGING CHART**

# 3.5 TON HP

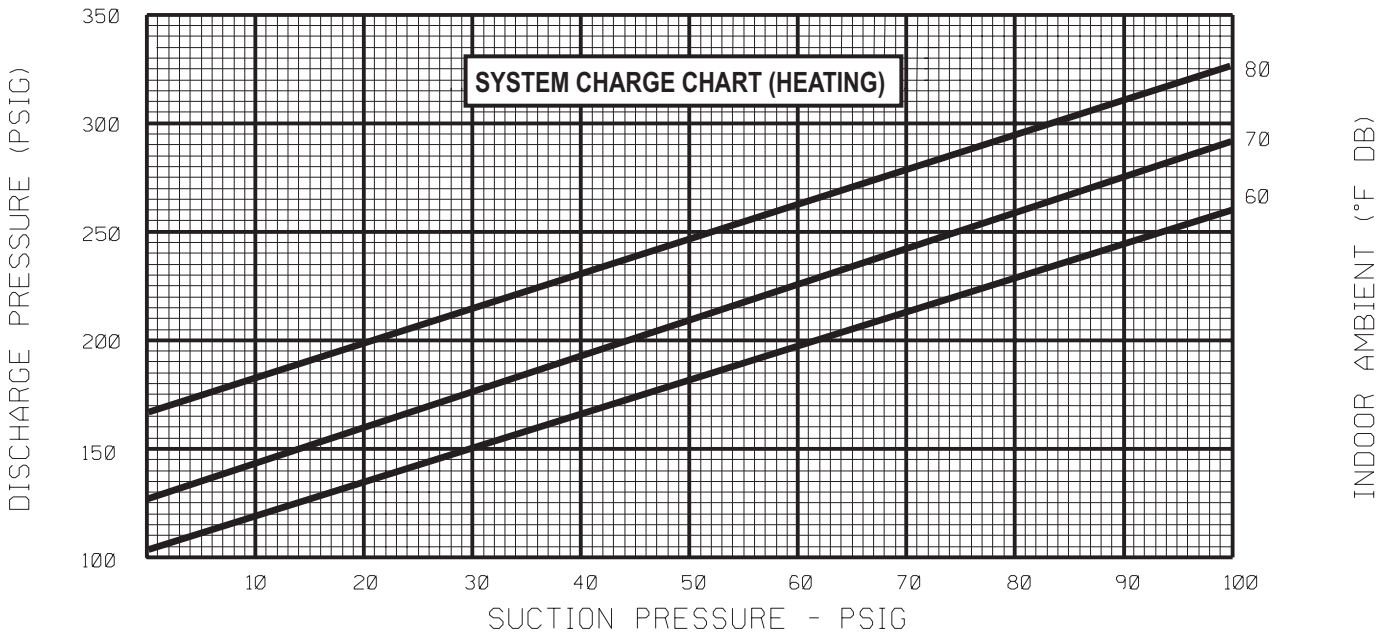
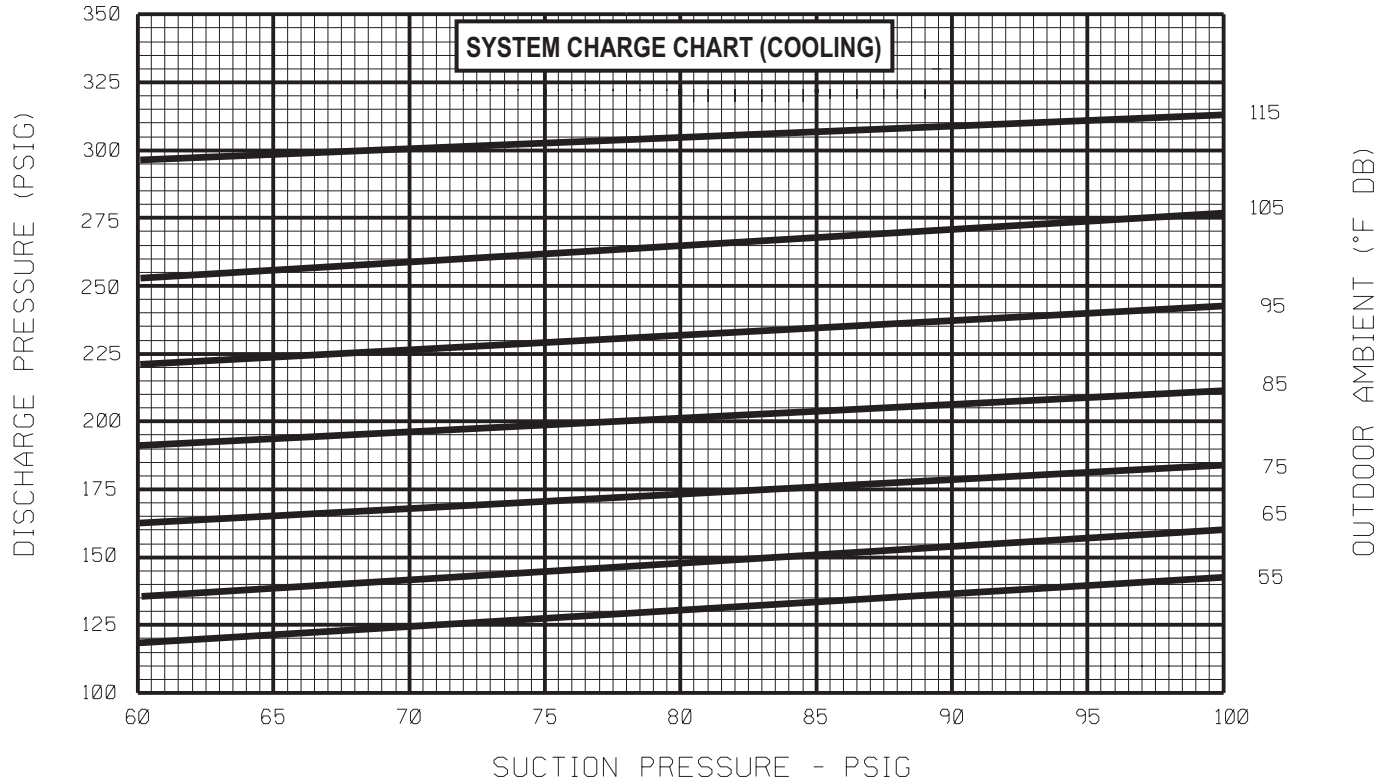

**CAUTION:** BEFORE FINAL REFRIGERANT CHECK, INDOOR RETURN AIR TEMPERATURE MUST BE BETWEEN 72°F & 76°F DB AT 50% R.H. (HEATING AND COOLING), AND NO ICE ON OUTDOOR COILS (HEATING).

**INSTRUCTIONS:**

1. CONNECT PRESSURE GAUGES TO SUCTION AND DISCHARGE PORTS ON UNIT.
2. MEASURE AIR TEMPERATURE TO: (a) OUTDOOR COIL FOR COOLING, (b) INDOOR COIL FOR HEATING.
3. PLACE AN "X" ON THE APPROPRIATE CHART WHERE THE SUCTION AND DISCHARGE PRESSURES CROSS.
4. IF "X" IS BELOW AMBIENT TEMPERATURE LINE, ADD CHARGE AND REPEAT STEP 3.
5. IF "X" IS ABOVE AMBIENT TEMPERATURE LINE, RECOVER EXCESS CHARGE AND REPEAT STEP 3.

92-100843-21-00



**FIGURE 17**  
**4.0 TON HEAT PUMP RQNJ CHARGING CHART**

# 4.0 TON HP

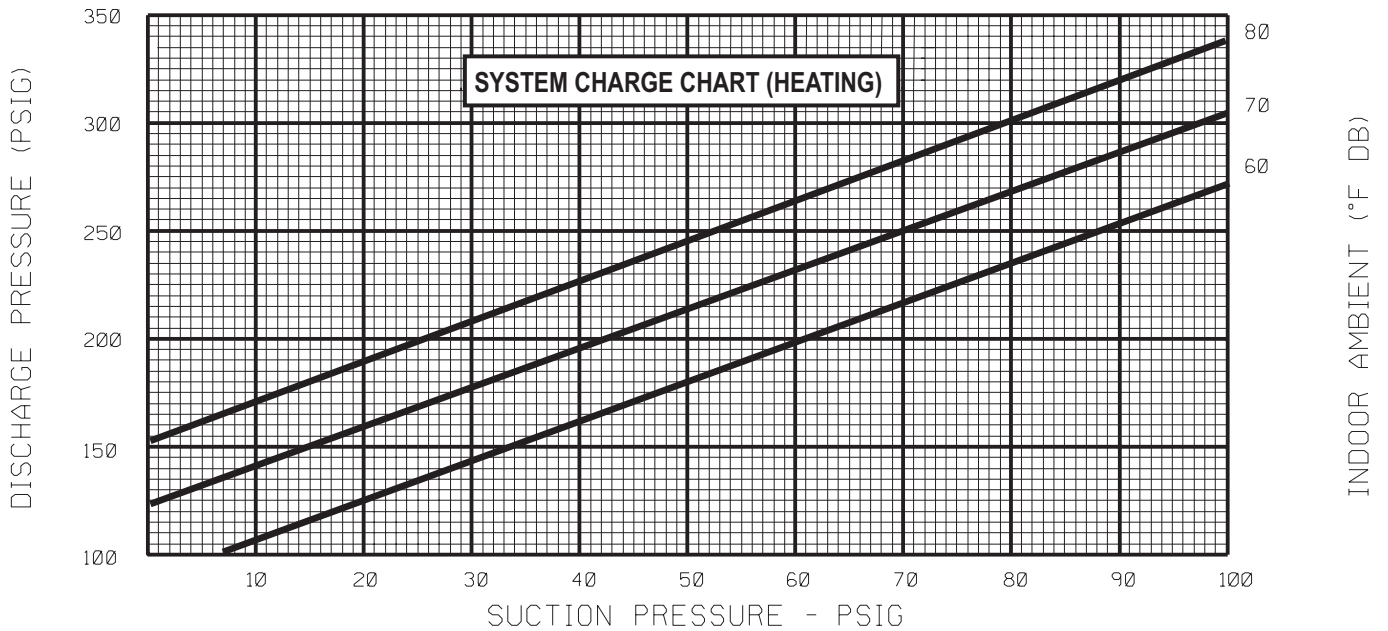
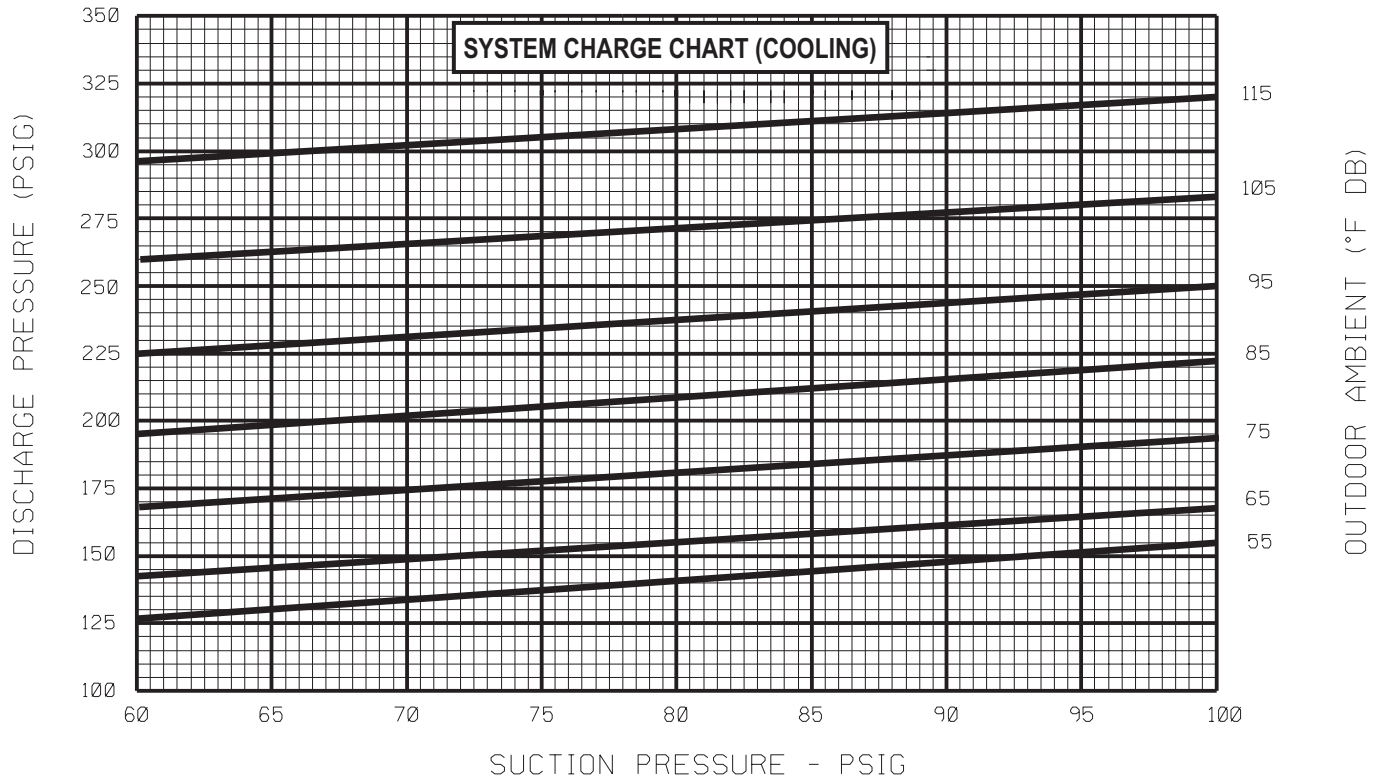

**CAUTION:** BEFORE FINAL REFRIGERANT CHECK, INDOOR RETURN AIR TEMPERATURE MUST BE BETWEEN 72°F & 76°F DB AT 50% R.H. (HEATING AND COOLING), AND NO ICE ON OUTDOOR COILS (HEATING).

**INSTRUCTIONS:**

1. CONNECT PRESSURE GAUGES TO SUCTION AND DISCHARGE PORTS ON UNIT.
2. MEASURE AIR TEMPERATURE TO: (a) OUTDOOR COIL FOR COOLING, (b) INDOOR COIL FOR HEATING.
3. PLACE AN "X" ON THE APPROPRIATE CHART WHERE THE SUCTION AND DISCHARGE PRESSURES CROSS.
4. IF "X" IS BELOW AMBIENT TEMPERATURE LINE, ADD CHARGE AND REPEAT STEP 3.
5. IF "X" IS ABOVE AMBIENT TEMPERATURE LINE, RECOVER EXCESS CHARGE AND REPEAT STEP 3.

**FIGURE 18**  
**5.0 TON HEAT PUMP RQNJ CHARGING CHART**

# 5.0 TON HP

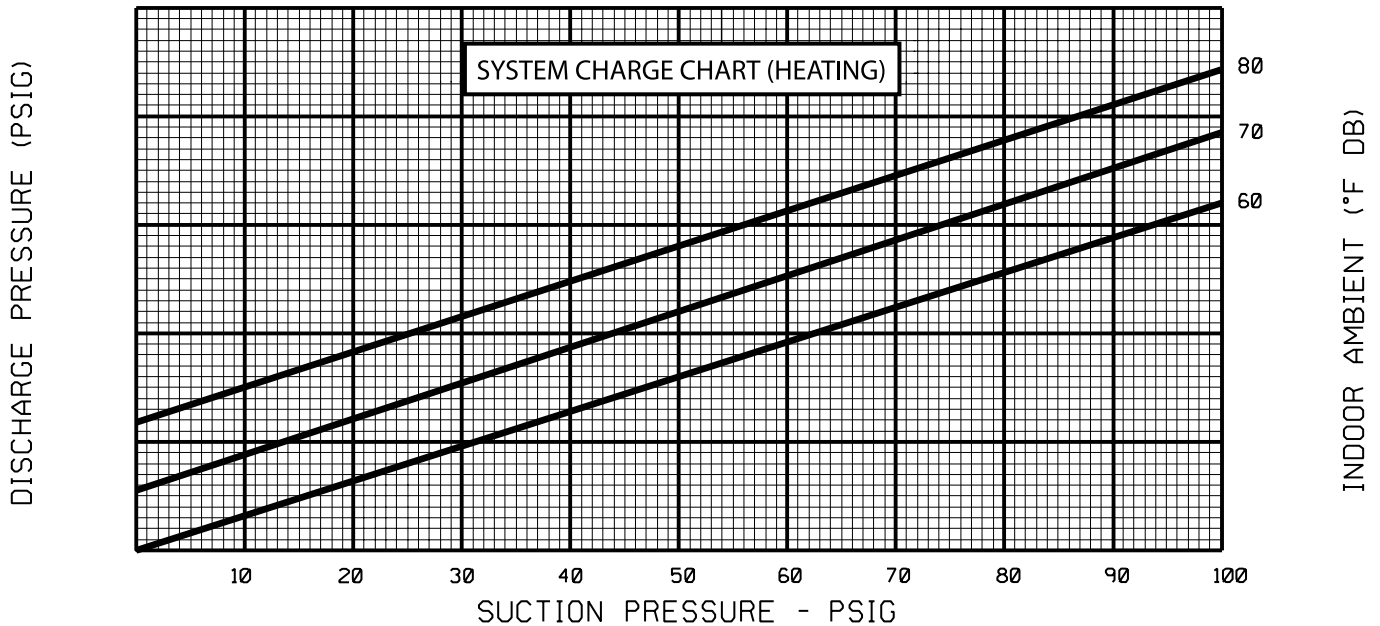
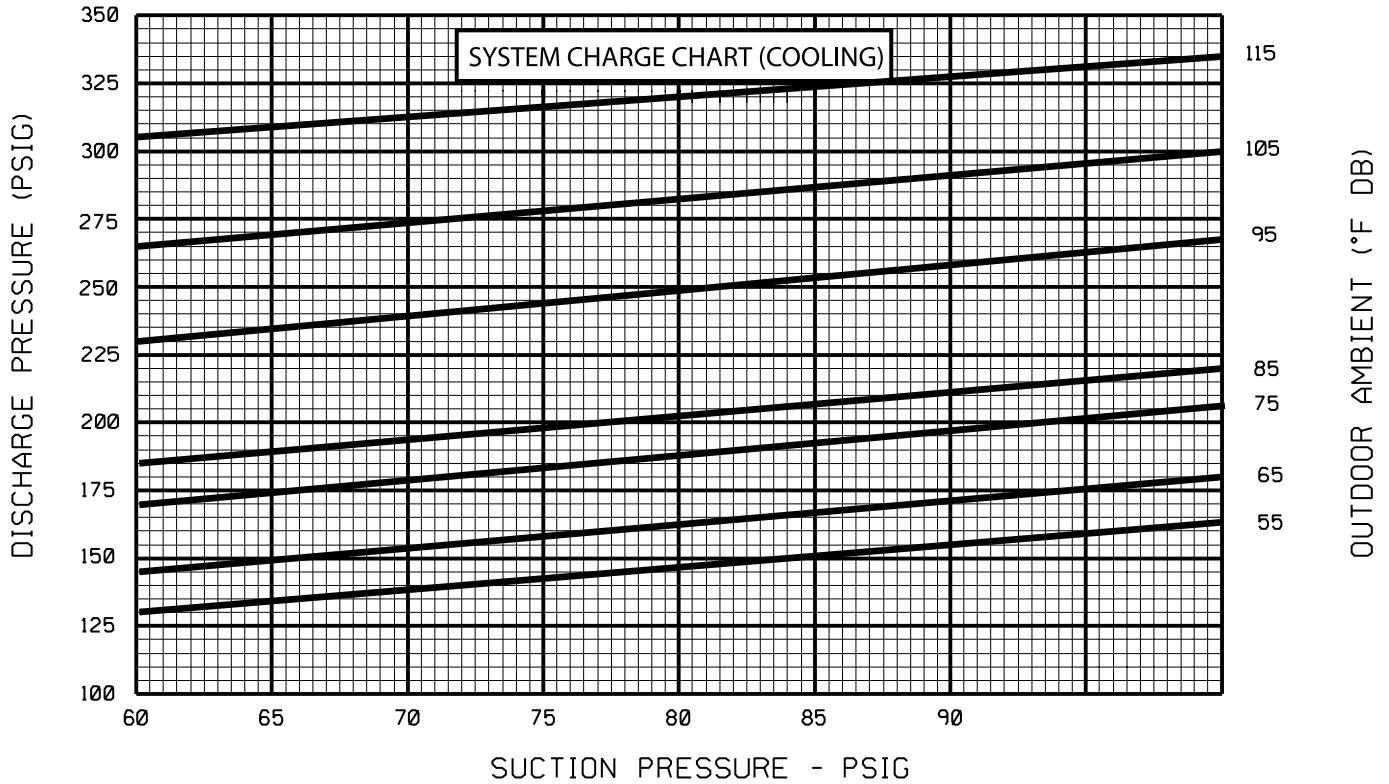

**CAUTION:** BEFORE FINAL REFRIGERANT CHECK, INDOOR RETURN AIR TEMPERATURE MUST BE BETWEEN 72°F & 76°F DB AT 50% R.H. (HEATING AND COOLING), AND NO ICE ON OUTDOOR COILS (HEATING).

1. CONNECT PRESSURE GAUGES TO SUCTION AND DISCHARGE PORTS ON UNIT.
2. MEASURE AIR TEMPERATURE TO: (a) OUTDOOR COIL FOR COOLING, (b) INDOOR COIL FOR HEATING.
3. PLACE AN "X" ON THE APPROPRIATE CHART WHERE THE SUCTION AND DISCHARGE PRESSURES CROSS.
4. IF "X" IS BELOW AMBIENT TEMPERATURE LINE, ADD CHARGE AND REPEAT STEP 3.
5. IF "X" IS ABOVE AMBIENT TEMPERATURE LINE, RECOVER EXCESS CHARGE AND REPEAT STEP 3.

92-100843-23-00

# TROUBLE SHOOTING CHART

**▲ WARNING**

**DISCONNECT ALL POWER TO UNIT BEFORE SERVICING. CONTACTOR MAY BREAK ONLY ONE SIDE. FAILURE TO SHUT OFF POWER CAN CAUSE ELECTRICAL SHOCK RESULTING IN PERSONAL INJURY OR DEATH.**

SYMPTOM	POSSIBLE CAUSE	REMEDY
Unit will not run	<ul style="list-style-type: none"> <li>• Power off or loose electrical connection</li> <li>• Thermostat out of calibration-set too high</li> <li>• Defective contactor</li> <li>• Blown fuses</li> <li>• Transformer defective</li> <li>• High pressure control open (if provided)</li> <li>• Interconnecting low voltage wiring damaged</li> </ul>	<ul style="list-style-type: none"> <li>• Check for correct voltage at compressor contactor in control box</li> <li>• Reset</li> <li>• Check for 24 volts at contactor coil - replace if contacts are open</li> <li>• Replace fuses</li> <li>• Check wiring-replace transformer</li> <li>• Reset-also see high head pressure remedy-The high pressure control opens at 450 PSIG</li> <li>• Replace thermostat wiring</li> </ul>
Condenser fan runs, compressor doesn't	<ul style="list-style-type: none"> <li>• Run or start capacitor defective (single phase only)</li> <li>• Start relay defective (single phase only)</li> <li>• Loose connection</li> <li>• Compressor stuck, grounded or open motor winding, open internal overload.</li> <li>• Low voltage condition</li> <li>• Low voltage condition</li> </ul>	<ul style="list-style-type: none"> <li>• Replace</li> <li>• Replace</li> <li>• Check for correct voltage at compressor - check &amp; tighten all connections</li> <li>• Wait at least 2 hours for overload to reset. If still open, replace the compressor. At compressor terminals, voltage must be within 10% of rating plate volts when unit is operating.</li> <li>• Add start kit components</li> </ul>
Insufficient cooling	<ul style="list-style-type: none"> <li>• Improperly sized unit</li> <li>• Improper airflow</li> <li>• Incorrect refrigerant charge</li> <li>• Air, non-condensibles or moisture in system</li> <li>• Incorrect voltage</li> </ul>	<ul style="list-style-type: none"> <li>• Recalculate load</li> <li>• Check - should be approximately 400 CFM per ton.</li> <li>• Charge per procedure attached to unit service panel</li> <li>• Recover refrigerant, evacuate &amp; recharge, add filter drier</li> <li>• At compressor terminals, voltage must be within 10% of rating plate volts when unit is operating.</li> </ul>
Compressor short cycles	<ul style="list-style-type: none"> <li>• Incorrect voltage</li> <li>• Defective overload protector</li> <li>• Refrigerant undercharge</li> </ul>	<ul style="list-style-type: none"> <li>• At compressor terminals, voltage must be <math>\pm 10\%</math> of nameplate marking when unit is operating.</li> <li>• Replace - check for correct voltage</li> <li>• Add refrigerant</li> </ul>
Registers sweat	<ul style="list-style-type: none"> <li>• Low evaporator airflow</li> </ul>	<ul style="list-style-type: none"> <li>• Increase speed of blower or reduce restriction - replace air filter</li> </ul>
High head-low vapor pressures	<ul style="list-style-type: none"> <li>• Restriction in liquid line, expansion device or filter drier</li> <li>• Flow check piston size too small</li> <li>• Incorrect capillary tubes</li> <li>• TXV does not open</li> </ul>	<ul style="list-style-type: none"> <li>• Remove or replace defective component</li> <li>• Change to correct size piston</li> <li>• Change coil assembly</li> <li>• Replace TXV</li> </ul>
High head-high or normal vapor pressure - Cooling mode	<ul style="list-style-type: none"> <li>• Dirty condenser coil</li> <li>• Refrigerant overcharge</li> <li>• Condenser fan not running</li> <li>• Air or non-condensibles in system</li> </ul>	<ul style="list-style-type: none"> <li>• Clean coil</li> <li>• Correct system charge</li> <li>• Repair or replace</li> <li>• Recover refrigerant, evacuate &amp; recharge</li> </ul>
High head-high or normal vapor pressure - Heating mode	<ul style="list-style-type: none"> <li>• Low air flow - condenser coil</li> <li>• Refrigerant overcharge</li> <li>• Air or non-condensibles in system</li> <li>• Dirty condenser coil</li> </ul>	<ul style="list-style-type: none"> <li>• Check filters - correct to speed</li> <li>• Correct system charge</li> <li>• Recover refrigerant, evacuate &amp; recharge</li> <li>• Check filter - clean coil</li> </ul>
Low head-high vapor pressures	<ul style="list-style-type: none"> <li>• Flow check piston size too large</li> <li>• Defective Compressor valves</li> <li>• Incorrect capillary tubes</li> </ul>	<ul style="list-style-type: none"> <li>• Change to correct size piston</li> <li>• Replace compressor</li> <li>• Replace coil assembly</li> </ul>
Low vapor - cool compressor - iced evaporator coil	<ul style="list-style-type: none"> <li>• Low evaporator airflow</li> <li>• Operating below 65°F outdoors</li> <li>• Moisture in system</li> <li>• TXV limiting refrigerant flow</li> </ul>	<ul style="list-style-type: none"> <li>• Increase speed of blower or reduce restriction - replace air filter</li> <li>• Add Low Ambient Kit</li> <li>• Recover refrigerant - evacuate &amp; recharge - add filter drier</li> <li>• Replace TXV</li> </ul>
High vapor pressure	<ul style="list-style-type: none"> <li>• Excessive load</li> <li>• Defective compressor</li> </ul>	<ul style="list-style-type: none"> <li>• Recheck load calculation</li> <li>• Replace</li> </ul>
Fluctuating head & vapor pressures	<ul style="list-style-type: none"> <li>• TXV hunting</li> <li>• Air or non-condensate in system</li> </ul>	<ul style="list-style-type: none"> <li>• Check TXV bulb clamp - check air distribution on coil - replace TXV</li> <li>• Recover refrigerant, evacuate &amp; recharge</li> </ul>
Gurgle or pulsing noise at expansion device or liquid line	<ul style="list-style-type: none"> <li>• Air or non-condensibles in system</li> </ul>	<ul style="list-style-type: none"> <li>• Recover refrigerant, evacuate &amp; recharge</li> </ul>

